

Safety and operating instructions Hydraulic bucket crusher

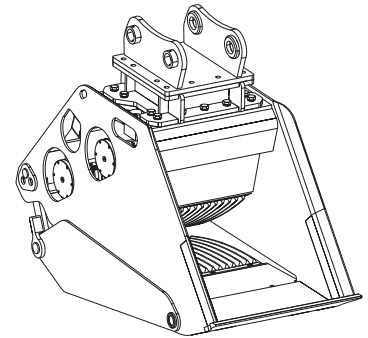

Interactive and updated spare part catalogues go to:
www.epiroc.com/technicaldocumentation

Table of Contents

1	Introduction	7
1.1	About these Safety and Operating Instructions.....	7
2	Safety instructions.....	8
2.1	Signal words.....	8
2.2	Qualification	9
2.3	Intended use	9
2.4	Use other than intended	10
2.5	Protective equipment.....	10
2.6	Carrier, precautions	10
2.7	Transport, precautions	11
2.8	Hydraulic installation, precautions	11
2.9	Media/consumables, precautions.....	12
2.10	Explosion and fire, precautions.....	12
2.11	Electrical shock, precautions	13
2.12	Falling stones, precautions.....	13
2.13	Emissions, precautions.....	13
2.14	Handling machines, precautions	13
2.15	Changes to the hydraulic attachment, precautions.....	13
2.16	Environmental pollution, precautions.....	13
3	Overview	14
3.1	Equipment description	14
3.2	Function	15
3.3	Signs / labels	15
3.3.1	Name plate	15
3.3.2	Labels	16
3.4	Applications.....	17
3.5	Guarantee	17
3.6	Removing the packaging.....	17
3.7	Scope of delivery	17
4	Transport	18
4.1	Transport using a crane	18
4.2	Transport using a forklift truck.....	18
4.3	Transport using a truck.....	19
5	Installation	20
5.1	Media/consumables	20
5.1.1	Mineral hydraulic oil.....	20
5.1.2	Non-mineral hydraulic oil	20
5.1.3	Grease	20
5.2	Manufacturing the adapter plate.....	21
5.3	Installing the adapter plate.....	21

5.4	Attaching the hydraulic attachment to the carrier	22
5.4.1	Mechanical mounting aspects	22
5.4.2	First installation / Making the hydraulic connections	23
5.5	Removing the hydraulic attachment from the carrier	25
5.5.1	Dismantling the hydraulic connections	25
5.5.2	Mechanical disassembly	25
5.6	Removing the adapter plate	26
6	Operation	27
6.1	Preparations before starting	27
6.2	Switching the bucket crusher on and off	28
6.3	Functional test	28
6.4	Correct operation	29
6.4.1	Filling the bucket crusher	29
6.4.2	Crushing material	29
6.4.3	Leveling crushed material	29
6.4.4	Releasing blocked material	29
6.4.5	Interrupting work	30
6.4.6	High ambient temperature	30
6.4.7	Low ambient temperature	30
6.5	Prohibited operation	31
6.5.1	Unsafe base	31
6.5.2	Use over the chain	31
6.5.3	Moving the carrier	31
6.5.4	Impacting/chopping	31
6.5.5	Cylinder end positions	32
6.5.6	Use under water	32
6.6	Adjusting the jaw outlet BC 2100	32
6.7	Adjusting the jaw outlet BC 2500, BC 3700, BC 5300	34
7	Maintenance	36
7.1	Maintenance schedule	37
7.2	Depressurising the hydraulic system	38
7.3	Cleaning	38
7.3.1	Preparations	38
7.3.2	Procedure	38
7.4	Checking the hydraulic attachment and adapter plate for cracks	38
7.5	Checking hydraulic lines	39
7.6	Checking bolted connections	39
7.7	Checking and cleaning the hydraulic oil filter of the carrier	39
7.8	Greasing the eccentric mechanism	39
7.9	Replacing wear parts	40
7.10	Bolt connections / Tightening torques	43
8	Troubleshooting	44
8.1	Bucket crusher does not work	44
8.2	Low impact from the jaws	44
8.3	Low crushing productivity	44
8.4	Strange sound during operation	44
8.5	Oil escapes at the control blocks	44

8.6	Oil escapes from the transmission housing	44
8.7	Oil escapes at the hydraulic motors	45
8.8	Cracks in the welding of the bucket crusher and/or adapter plate	45
9	Repair	46
9.1	Sending in the hydraulic attachment for repairs	46
9.2	Welding	46
10	Storage	47
10.1	Long-term storage	47
10.2	Hydraulic hoses	47
11	Disposal	48
11.1	Bucket crusher	48
11.2	Hydraulic hoses	48
11.3	Hydraulic oil.....	48
12	Technical specifications.....	49
12.1	Hydraulic plan control valve block BC 2100, BC 2500, BC 3700	50
12.2	Hydraulic plan control valve block BC 5300.....	51
13	EC Declaration of Conformity (EC Directive 2006/42/EC)	52

1 Introduction

Epiroc is a leading productivity partner for the mining, infrastructure and natural resources industries. With cutting-edge technology, Epiroc develops and produces innovative drill rigs, rock excavation and construction equipment, and provides world-class service and consumables.

The company was founded in Stockholm, Sweden, and has passionate people supporting and collaborating with customers in more than 150 countries.

Construction Tools GmbH

P.O. Box: 102152

Helenenstraße 149

D - 45021 Essen

Tel.: +49 201 633-0

1.1 About these Safety and Operating Instructions



The aim of these Instructions is to familiarise you with the safe and effective operation of the hydraulic attachment. You will also find instructions for regular maintenance activities for the hydraulic attachment in this document.

Please read these Instructions carefully prior to the first attachment and use of the hydraulic attachment.



The different designation of the texts means as follows:

▶	Action step in a safety instruction
◆	Action step
1. 2.	Established operation process
A B C	Explanation of the elements of a drawing
• • •	Listing

Symbols used in illustrations have the following meanings:

	permitted operation
	prohibited operation

2 Safety instructions

	This is the safety alert symbol. It is used to alert you to potential personal injury hazards. Obey all safety messages that follow this symbol to avoid possible injury or death.
	Read these Safety and operating instructions and specifically all safety instructions before using the hydraulic attachment. This will: <ul style="list-style-type: none"> • prevent the risk of injuries and fatal accidents for yourself and others, • protect the environment against environmental damage. • protect the hydraulic attachment and other property against material damage,

Follow all instructions in these Safety and operating instructions.

Store these Safety and operating instructions in the document compartment of the carrier cab.

Anyone

- transporting,
- installing or removing,
- operating,
- maintaining,
- repairing,
- storing or
- disposing of

the hydraulic attachment must have read and understood these Safety and operating instructions.

These Safety and operating instructions belong to the hydraulic attachment. Keep it for the life of the product. Ensure, if applicable, that any received amendment is incorporated in the instructions. Hand over the Safety and operating instructions if ever you lend, rent out or sell the hydraulic attachment.

All safety regulations listed in this manual comply with the laws and regulations of the European Union. Also observe the additional national/regional regulations.

Hydraulic attachment operation outside the European Union is subject to the laws and regulations valid in the country of use. Please observe any other, more stringent regional regulations and legislation.

Read the carrier manufacturer's Safety and operating Instructions before attaching the hydraulic attachment to the carrier and operating it. Observe all instructions.

2.1 Signal words

The signal words Danger, Warning, Caution, and Notice are used as follows in these Safety and operating instructions:

DANGER	indicates a hazardous situation which, if not avoided, will result in death or serious injury.
WARNING	indicates a hazardous situation which, if not avoided, could result in death or serious injury.
CAUTION	indicates a hazardous situation which, if not avoided, could result in minor or moderate injury.
NOTICE	The signal word NOTICE is used to address practices related to possible property damage but not related to personal injury.

2.2 Qualification

Transporting the hydraulic attachment is only permitted if carried out by people who:

- are authorised to operate a crane or a forklift truck according to the applicable national provisions,
- know all the relevant national/regional safety provisions and accident prevention rules,
- have read and understood the safety and transport chapter of these Safety and operating instructions.

Installing, maintaining, storing and disposing of the hydraulic attachment are only permitted if carried out by people who:

- know all the relevant national/regional safety provisions and accident prevention rules,
- have read and understood these Safety and operating instructions.

Welding of the hydraulic attachment is only permitted if carried out by qualified welders who:

- have been trained to operate MIG welding equipment according to the national regulations,
- know all the relevant national/regional safety provisions and accident prevention rules,
- have read and understood these Safety and operating instructions.

Operating the hydraulic attachment is only permitted if carried out by qualified carrier drivers. Carrier drivers are qualified if they:

- have been trained to operate a carrier according to the national regulations,
- know all the relevant national/regional safety provisions and accident prevention rules,
- have read and understood these Safety and operating instructions.

Testing the hydraulic installation is only permitted if carried out by professionals. Professionals are people who are authorised to approve a hydraulic installation for operation according to the national regulations.

Repairing the hydraulic attachment is only permitted if carried out by professionals trained by Construction Tools GmbH. These professionals must have read and understood these Safety and operating instructions. Otherwise the operational safety of the hydraulic attachment is not guaranteed.

2.3 Intended use

The bucket crusher is designed for volumetric reduction of inert materials coming from demolitions.

Only attach the bucket crusher to a hydraulic carrier of a suitable load-bearing capacity. Read the carrier manufacturer's Safety and operating instructions before attaching the bucket crusher to the carrier and operating it. Observe all instructions.

Only use the bucket crusher for following operations:

- Crushing and crumbling stone, concrete, asphalt, brickwork etc...
- Crushing hard materials like granite or porphyry is permitted, provided they have less than 90 % of the jaw inlet size x .

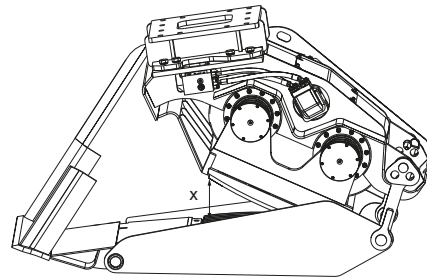

- Crushing materials with high hardness should have less than 60 % of the jaw inlet size x .
- Removing and pushing aside shredded material to clean the work area.
- Continuous operation (24 hours/7 days) is not allowed and requires additional technical activities and service intervals. For technical support contact the Epiroc Customer Center / Dealer in your area.

Intended use also implies observing all instructions in these Safety and operating instructions.

2.4 Use other than intended

Never use the bucket crusher:

- for continuous operation (24 hours/7 days).

This damages the bucket crusher.

- for direct extraction or excavation

This damages the bucket crusher.

- for wet material

This shortens the life of the jaws. Continuously grinding shortens the life of the whole bucket crusher.

- to hit or chop

This destroys the bucket crusher.

- to move the carrier supported by the bucket crusher

This damages the bucket crusher.

- to lift or transport people

This may cause serious injury or death.

- to lift or transport loads

This damages the bucket crusher.

- with temperatures above 100 °C (212 °F) or below -20 °C (-4 °F)

This destroys the bucket crusher.

- under water

This destroys the bucket crusher.

- in explosion-hazard environments

Explosions cause serious injury or death.

2.5 Protective equipment

Personal protective equipment must comply with the applicable health and safety regulations.

- Do not work wearing jewelry or with loose long hair. Moving machine parts could catch your hair or jewelry causing serious injury.
- Wear comfortable, close-fitting work clothes. The moving machine parts can snag loose clothing and cause serious injury.

Always wear the following personal protective equipment:

- protective helmet
- safety glasses with side protectors
- protective gloves
- protective shoes
- warning vest
- hearing protection

2.6 Carrier, precautions

▲ WARNING Falling carrier

If the load-bearing capacity of the carrier used is insufficient, the carrier will not be stable. It can topple over and cause injuries and damage.

Consider the full load (weight of the bucket crusher + loaded material + adapter plate + accessories).

Using a carrier whose load-bearing capacity is too high, may cause mechanical overloading of the bucket crusher.

- ▶ Only attach the bucket crusher to a hydraulic carrier of a suitable load-bearing capacity.
- ▶ The carrier must remain stable at all times.
- ▶ For installation to wheel loaders it is mandatory to set the stabilizers on the ground before connecting and lifting the bucket crusher.
- ▶ Read the carrier manufacturer's Safety and operating instructions before attaching the bucket crusher to the carrier and operating it. Observe all instructions.

2.7 Transport, precautions

▲ **WARNING Risk of death due to suspended loads**

When lifting loads these can swing out and fall. This can result in serious injuries or even death.

- ▶ Never stand underneath or in the swinging range of suspended loads.
- ▶ Only move loads under supervision.
- ▶ Only use approved lifting equipment and lifting gear with sufficient load bearing capacity.
- ▶ Do not use worn lifting gear (ropes, belts, chains, shackles etc.).
- ▶ Do not place lifting gear such as ropes and belts on sharp edges or corners, do not knot these or twist them.
- ▶ When leaving the workplace, set down the load.

▲ **WARNING Injury due to swivelling load**

When transporting the load by crane it can swivel and cause severe injuries and considerable damage to property.

- ▶ Ensure that no personnel, objects or obstacles are located in the swivel range of the load.

2.8 Hydraulic installation, precautions

▲ **WARNING Hydraulic pressure too high**

If the hydraulic pressure is too high, the parts of the hydraulic attachment will be exposed to excessively high loads. Parts can break loose or burst causing serious injuries.

- ▶ Lay the drain line of the pressure relief valve directly in the tank to ensure the safe functioning of the pressure relief valve!
- ▶ The pressure relief valve must be set at the maximum static pressure.
- ▶ The pressure relief valve setting must be checked to ensure that the maximum static pressure (see chapter **Technical specifications**) of the hydraulic installation is not exceeded at any time. Attach a lead seal to the pressure relief valve.
- ▶ Prior to their first use, the safety facilities on the hydraulic installation must be checked by a professional/authorised monitoring body for their quality (CE mark etc.), suitability and proper functioning.
- ▶ If any significant changes are made to the hydraulic installation, a new acceptance inspection is to be carried out in accordance with the relevant national safety provisions.

▲ **WARNING Hot hydraulic oil squirting out**

The hydraulic system is under high pressure. Hydraulic lines may spring a leak or burst. Hydraulic oil squirting out can lead to serious injury.

- ▶ When attaching the hydraulic attachment do not lay any hydraulic lines through the carrier's cab.
- ▶ Only use hydraulic lines which comply with the following quality requirements:
 - Hydraulic hoses with 4 reinforcement steel wires according to DIN EN 856 4SH,
 - Hydraulic pipes, seamless cold-drawn steel pipes according to DIN EN 10305

2.9 Media/consumables, precautions

▲ **WARNING Hot hydraulic oil under high pressure**

Hydraulic oil will squirt out under high pressure if there is a leakage. The jet of oil might penetrate people's skin and cause permanent damage. Hot hydraulic oil can cause burns.

- ▶ Never use your hands to find leaks.
- ▶ Always keep your face away from a possible leak.
- ▶ If hydraulic oil has penetrated your skin consult a doctor immediately.

▲ **WARNING Hydraulic oil spills**

Spilt hydraulic oil can make a floor slippery. If people slip they can be injured. Hydraulic oil is environmentally harmful and must not penetrate the ground or enter the water table or water supplies.

- ▶ Make sure not to spill any hydraulic oil.
- ▶ Immediately clean the floor if you have spilt hydraulic oil.
- ▶ Observe all safety and environmental protection provisions when handling hydraulic oil.

▲ **WARNING Skin infections/diseases due to oil and grease**

Hydraulic oil and grease can cause rashes (or even eczema) if they come into contact with the skin.

- ▶ Avoid all skin contact with hydraulic oil and grease.
- ▶ Use a suitable skin protection product.
- ▶ Always wear safety gloves when working with hydraulic oil or grease.
- ▶ Immediately clean any skin that has been contaminated by oil or grease with water and soap.

2.10 Explosion and fire, precautions

▲ **DANGER Explosion and fire**

Explosions cause serious injury or death. Explosives being crushed by the bucket crusher may lead to an explosion.

- ▶ Never operate the bucket crusher in the direct vicinity of explosives.
- ▶ Make sure that no explosives are hidden in the material.
- ▶ Check gas line position plans of the complete working area.

▲ **DANGER Explosion and fire**

Operating the bucket crusher may create sparks which ignite highly flammable gases. This may lead to fire or an explosion.

- ▶ Never work in an environment with highly flammable substances.
- ▶ Make sure that there are no hidden sources of gas in the work area.
- ▶ Check gas line position plans of the complete construction area.

▲ **DANGER Explosion and fire**

Dust-rich air can form an explosive atmosphere which may ignite when operating the bucket crusher. This may lead to fire or an explosion.

- ▶ Never operate the bucket crusher in an explosion-hazard atmosphere.
- ▶ Always provide sufficient ventilation when working in buildings or in a confined area.

2.11 Electrical shock, precautions

▲ DANGER Electrical shock

Any contact of the hydraulic attachment with electric circuits or other sources of electricity will lead to an electric shock, resulting in serious injury or death. The hydraulic attachment is not electrically insulated.

- ▶ Never work in the vicinity of electric circuits or other sources of electricity.
- ▶ Make sure that there are no hidden circuits in the work area.
- ▶ Check wiring diagrams.

2.12 Falling stones, precautions

▲ WARNING Fragments flying around

Fragments of material which come loose while operating the hydraulic attachment may be flung away and can cause serious injury if people are hit by them. Small objects falling from a great height can also cause serious damage.

During hydraulic attachment operation the danger zone is considerably greater than during the excavation operation due to fragments of stone and pieces of steel flying around, and for this reason the danger zone must, depending on the type of material to be worked on, be enlarged correspondingly, or secured in a suitable manner through corresponding measures.

- ▶ Secure the danger zone.
- ▶ Stop the hydraulic attachment immediately if anyone enters the danger zone.
- ▶ Close the windscreen and the side windows of the driver's cab.

2.13 Emissions, precautions

▲ WARNING Lung disease

Dust may be generated when operating the hydraulic attachment. If dust from rocks or silica dust, produced when operating the hydraulic attachment on rocks, concrete, asphalt or other such materials, is inhaled this may lead to silicosis (dust lungs, a severe lung disease). Silicosis is a chronic disease which may lead cancer and death.

- ▶ Wear a suitable breathing mask.

2.14 Handling machines, precautions

▲ WARNING Narcotics, alcohol and drugs

Narcotics, alcohol and medicinal drugs make their users less alert and affect their ability to concentrate. Negligence and incorrectly assessing a situation can result in serious injury or death.

- ▶ Never work on or with the hydraulic attachment when under the influence of narcotics, alcohol or drugs which affect your alertness.
- ▶ Never allow other people who are under the influence of narcotics, alcohol or drugs which affect their alertness to work on or with the hydraulic attachment.

2.15 Changes to the hydraulic attachment, precautions

▲ WARNING Changes to the hydraulic attachment

Changes to the hydraulic attachment or the adapter plate may lead to serious injury.

- ▶ Never carry out any changes to the hydraulic attachment or the adapter plate.
- ▶ Only use original parts or accessories approved by Epiroc.
- ▶ Modifications that entail new hazards may require a new procedure for assessing conformity.

2.16 Environmental pollution, precautions

NOTICE Environmental pollution due to hydraulic oil

Hydraulic oil is permanently environmentally harmful. Escaped hydraulic oil will lead to groundwater and soil contamination. Organisms may die.

- ▶ Collect any hydraulic oil which escapes to avoid environmental pollution. For minor volumes use an absorbing medium (in case of an emergency use soil). In case of major leakages contain the hydraulic oil. It must not drain off and penetrate the ground or enter the water table or water supplies.
- ▶ Collect contaminated absorbing medium or soil in a watertight box/container and close it tight.
- ▶ Contact an authorized waste management company.
- ▶ Dispose of all contaminated material in accordance with the applicable environmental regulations.

3 Overview

3.1 Equipment description

The illustration gives an overview of the main parts and components of the hydraulic attachment. Actual details may differ.

Make sure that the carrier circuit is in the “double effect” position (shear or clamp).

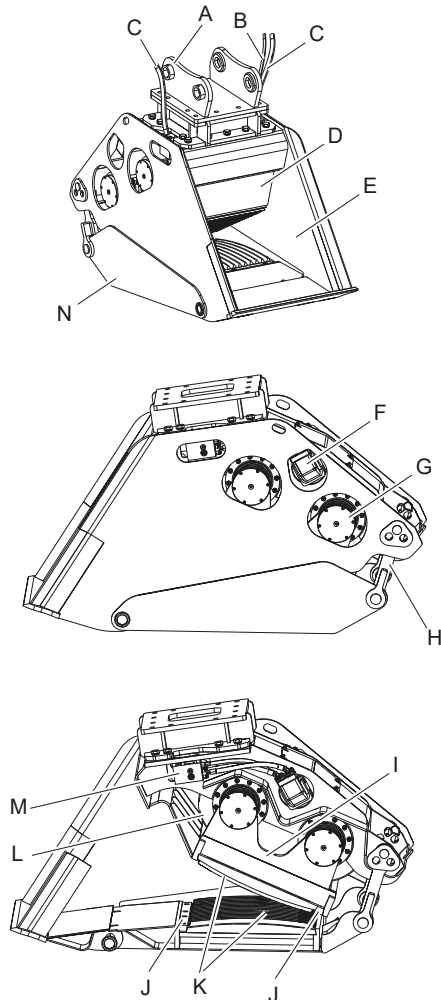

- A. The bucket crusher is connected to the carrier by the **adapter plate**. The adapter plate is not included in the scope of supply of the bucket crusher.
- B. Leakage oil line
- C. Pressure line
- D. The **mobile support** consists of the upper jaw, bridges, pins and the transmission housing.
- E. The **housing** covers the whole set of units in the mobile support. It has also threaded holes where the adapter plate is fixed.
- F. The **hydraulic motors** provide movement to the mobile support.

- G. The set of **shaft-pulleys** transmit the motion from the hydraulic motors to the mobile support. The shaft-pulleys are connected to eccentric bolts and together form the eccentric mechanism.
- H. The adjustable parts of the **tensioner system** enables you to change the jaws outlet opening. The smaller the opening, the smaller the size of the crushed material.
- I. The bridges are joining the axes to the upper jaw.
- J. The **wedges** fix the jaws.
- K. The **jaws** are casting pieces, whose physical properties and geometry are conducive to crushing the material.
- L. The **transmission housing** protects the engine operating mechanisms.
- M. The **control blocks** are the hydraulic units that protect and control the start and stop, and also the motors direction shift.
- N. The **lower support** is attached to the housing by two pins and two adjustable turnbuckles to enable the modification of the jaws outlet opening. The lower jaw is attached to the lower support.

3.2 Function

The operation of a hydraulic bucket crusher is described in a simplified version below:

The pressure line supplies oil to the control block of the bucket crusher. The control block supplies the hydraulic motors with regulated oil pressure and oil flow.

The hydraulic motors provide the movement of the upper jaw. The fixed lower jaw produces the necessary counter-pressure which is required for the crushing the material. The bucket crusher is during crushing operation in a vertical position. The crushed material can fall out downwards.

3.3 Signs / labels

▲ WARNING Missing warnings

The name plate and the labels on the hydraulic attachment contain important information about the hydraulic attachment and for personal safety. A missing warning can lead to overlooking or misinterpretation of possible risks and cause personal hazards. The signs and labels must always be clearly legible.

- ▶ Immediately replace any defective name plates and labels.
- ▶ Use the spare parts list to order new name plates and labels.

3.3.1 Name plate

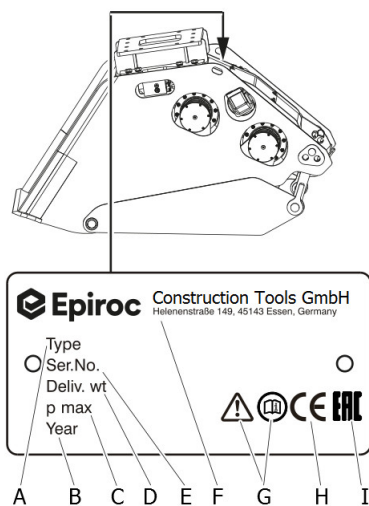



- A. Model
- B. Year of construction of hydraulic attachment
- C. Max. permissible operating pressure
- D. Weight of hydraulic attachment
- E. Serial number
- F. Name and address of manufacturer

- G. The warning symbol and the book symbol indicate that the Safety and Operating Instructions must be read prior to use of the hydraulic tool and in particular the chapter on Safety.
- H. The CE symbol indicates that the hydraulic attachment was produced in conformity with CE. You can find further information about this in the enclosed EC Declaration of Conformity.
- I. The EAC symbol means that the machine is EAC approved.

3.3.2 Labels

Read all instructions	
	The warning symbol and the book symbol indicate that the Safety and Operating Instructions must be read prior to use of the hydraulic attachment and in particular the chapter on Safety.

Noise level	
	Noise level: 85 dB. Use ears protection.

Danger zone	
	No persons should be within the danger zone of minimum 20 m. Fragments of material which come loose while operating the hydraulic attachment may be flung away and can cause serious injury if people are hit by them. Small objects falling from a great height can also cause serious damage.

System under high pressure	
	The label states system under high pressure. Depressurise the hydraulic system before servicing.

Crush hazard	
	There is a risk of crushing between moving parts. Keep away from moving parts.

Entanglement hazard	
	Pinch point. There is a risk of entanglement. Keep away from moving parts.

Burn hazard	
	There is a risk of burn hazards. Never touch hot parts. Allow to cool down before servicing.

Hazards caused by jets of hot hydraulic oil	
	Jets of hot hydraulic oil may squirt out under high pressure and lead to serious injury. Depressurise the hydraulic system before servicing.

3.4 Applications

Field	Type of application
Recycling	On-site crushing of inert demolition material like asphalt, stone and concrete debris
Demolition work	On-site crushing of mine and quarry material

3.5 Guarantee

The guarantee or product liability will be invalidated by the following:

- Use other than intended
- Maintenance work not being carried out or being carried out incorrectly
- The use of incorrect consumables
- The use of non-approved parts
- Damage due to wear
- Damage due to improper storage
- Changes not carried out by or in consultation with the manufacturer

3.6 Removing the packaging

- Remove all the packaging material.
- Dispose of it in accordance with the applicable provisions.
- Check that the delivery is complete.
- Check the delivery for visual damage.
- If any defects are found, consult the Epiroc Customer Center / dealer in your area.

3.7 Scope of delivery

The hydraulic bucket crusher is delivered complete with:

- Hydraulic bucket crusher
- Safety and operating instructions
- EC Declaration of Conformity

Accessories as ordered:

- Hoses

Special accessories as ordered:

- e.g. adapter plate with Allen screws and pairs of lock washers
- e.g. base plate to construct an adapter plate with Allen screws and pairs of lock washers
- e.g. hydraulic fittings for the carrier

4 Transport

▲ **WARNING** Hoist tipping over / hydraulic attachment falling

The hydraulic attachment is heavy. The hoist/lifting equipment and/or hydraulic attachment tipping over or falling may cause serious injury and material damage.

- ▶ Only transport the hydraulic attachment with lifting equipment with the right load-bearing capacity for the weight of the hydraulic attachment.
- ▶ Only lift and secure the hydraulic attachment with lifting gear (ropes, chains, shackles etc.) with the right load-bearing capacity for the weight to be lifted.
- ▶ Make sure that there is nobody near or under the suspended hydraulic attachment.

4.1 Transport using a crane

- Secure the hydraulic attachment with ropes or chains as shown in the following illustration.

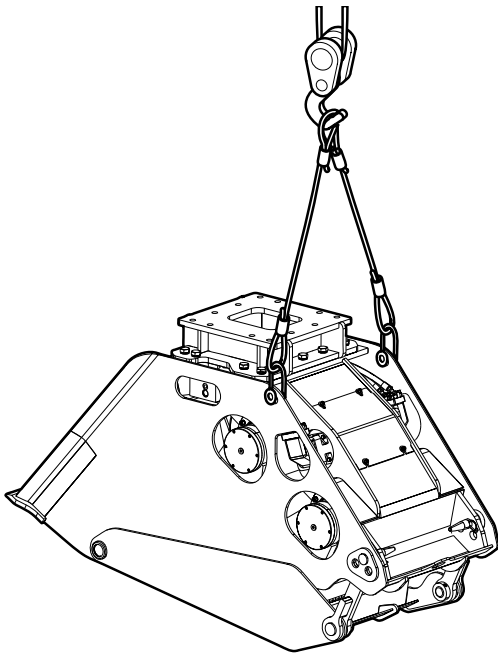

- Slowly lift the hydraulic attachment.
- Place the hydraulic attachment on a pallet.

4.2 Transport using a forklift truck

▲ **WARNING** Hydraulic attachment tipping over

The hydraulic attachment tipping off the fork of the forklift truck or the pallet may cause serious injury.

- ▶ Place the hydraulic attachment on a pallet.
- ▶ Strap the hydraulic attachment to the pallet using suitable strapping, as shown in the illustration below.
- ▶ Move the fork of the forklift truck under the pallet so that the centre of gravity is between the prongs.

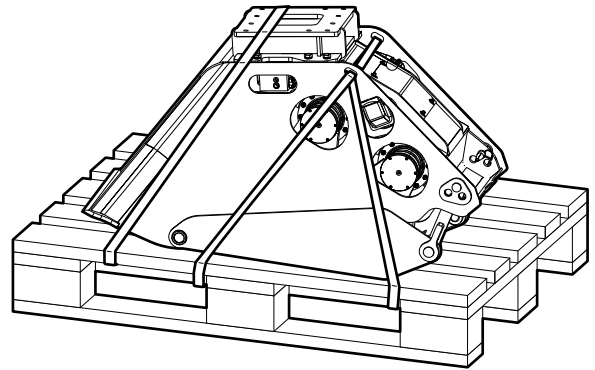

- Move the fork of the forklift truck under the pallet so that the hydraulic attachment cannot tip over.

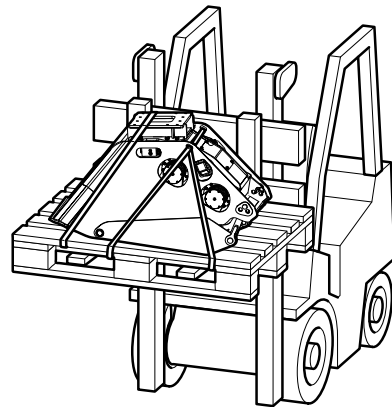

- Slowly lift the pallet with the hydraulic attachment.
- Transport the pallet with the hydraulic attachment to the location provided for.

4.3 Transport using a truck

▲ **WARNING Hydraulic attachment tipping over / slipping**

The hydraulic attachment slipping or tipping over and falling from the loading area of a lorry may cause serious injury.

- ▶ Place the hydraulic attachment on a pallet.
- ▶ Strap the hydraulic attachment to the pallet using suitable strapping (see illustration in chapter **Transport using a forklift truck**).
- ▶ Place the pallet with the hydraulic attachment on an anti-slip mat.
- ▶ Secure the hydraulic attachment to the loading area with ropes or chains; use any available transport lugs.
- Secure the hydraulic attachment on the pallet and the loading surface as shown in the following illustration.
- Observe all the applicable national/regional regulations on securing loads.

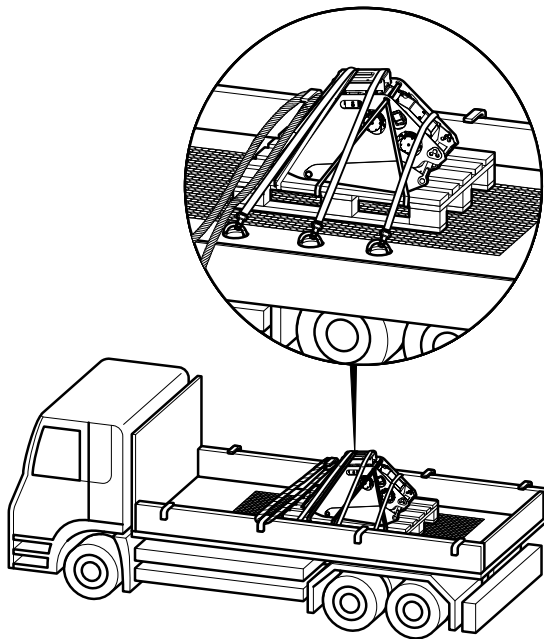

5 Installation

▲ WARNING Hot hydraulic oil squirting out

The hydraulic system is under high pressure. If hydraulic connections come loose or are disconnected, hydraulic oil will squirt out under high pressure. Hydraulic oil squirting out can lead to serious injury.

- ▶ Depressurise the hydraulic system before connecting or disconnecting the hydraulic circuits of the hydraulic attachment (see chapter **Depressurising the hydraulic system**).

NOTICE Environmental damage due to hydraulic oil

Hydraulic oil is environmentally harmful and must not penetrate the ground or enter the water table or water supplies.

- ▶ Collect any hydraulic oil which escapes.
- ▶ Dispose of it in accordance with the applicable environmental regulations.

5.1 Media/consumables

The following consumables are used when operating the hydraulic attachment:

5.1.1 Mineral hydraulic oil

All hydraulic oil brands prescribed by the carrier manufacturer are also suitable for use when operating the hydraulic attachment.

However, the oil should comply with viscosity class HLP 32 or higher.

In summer and in hot climates, oils of viscosity class HLP 68 or higher should be used.

In all other respects the regulations of the carrier manufacturer are to be taken into consideration.

Optimum viscosity range	= 40 - 60 cSt
Max. start viscosity	= 2000 cSt
Max. oil temperature	= 80 °C

Special conditions apply to using the hydraulic attachment at low temperatures (see section **Low ambient temperature**).

- Check the oil filter!

An oil filter with magnetic separator must be integrated in the return circuit of the hydraulic system. The maximum mesh width the hydraulic motor's manufacturer recommends for the oil filter is 20 microns. It is preferable to use 10 µm filters to ensure trouble-free operation.

5.1.2 Non-mineral hydraulic oil

NOTICE Mixed hydraulic oil

Never mix mineral and non-mineral hydraulic oils! Even small traces of mineral oil mixed in with non-mineral oil can result in damage to both the hydraulic attachment and the carrier. Non-mineral oil loses its biodegradability.

- ▶ Only use one type of hydraulic oil.

If you are using non-mineral oil it is imperative that the name of the oil in use be indicated when returning the hydraulic attachment for repair.

In order to protect the environment or on technical grounds, hydraulic oils are currently being used which are not classified as HLP mineral oils.

Before using hydraulic oils of this kind it is imperative to ask the carrier manufacturer whether operations with such fluids are possible.

Our hydraulic attachments are basically designed for use with mineral oils. Consult the Epiroc Customer Center / Dealer in your area before using other hydraulic oils approved by the carrier manufacturer. Following initial assembly and after any workshop repairs, our hydraulic attachments are subjected to a test run on a test bed powered by **mineral oil**.

5.1.3 Grease

- When handling oils and greases observe the safety instructions that apply to these products.

Free flow Grease

400 g (14 oz) cartridges packed per 12 cartridges: part number 3363 1222 50

5.2 Manufacturing the adapter plate

Construction Tools GmbH also supplies base plates to manufacture adapter plates alternatively to the adapter plates supplied.

NOTICE Adapter plate cracking

The adapter plate may crack if it is not designed for the high load.

- ▶ Take not only the weight of the hydraulic attachment but also the crowd force of the carrier, possible vibration etc. into account when dimensioning the adapter plate.
- ▶ Ensure that the design conforms to the state of the art.
- ▶ Have the web plates welded to the adapter plate base plate by a qualified welding specialist.

The base plate is made of the material EN10025-S355 J2G3.

- Have the web plates designed and manufactured or procure web plates to fit your carrier.
- Ensure that the web plates are welded to the base plate side marked "TOP".

The adapter plate must not strike in any position during operation of the hydraulic attachment.

Construction Tools GmbH does not design, manufacture or sell web plates for adapter plates.

5.3 Installing the adapter plate

NOTICE The adapter plate can come loose

The adapter plate can come loose if the fastening screws are not designed for local high loads.

- ▶ Only use the Allen screws of strength category 8.8 and the pairs of lock washers included in the delivery to attach the adapter plate or the base plate.
- Place the bucket crusher within the range of the carrier.
- Apply anti-seize compound to the Allen screw threads (A) before inserting them.

The contact faces of the screw head and the lock washers (B) must not be lubricated.

▲ WARNING Hands and fingers being cut off or hurt

Bores and surfaces can act like a pair of scissors and cut off or hurt parts of your body.

- ▶ Never use your fingers to check bores or fitting surfaces.
- Align the adapter plate (D) to the connection plate (C) of the bucket crusher.

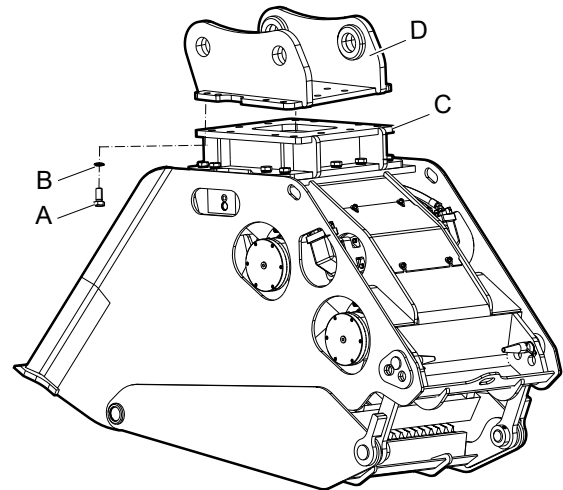

- Fit a pair of lock washers (B) onto every screw.
- Tighten the Allen screws (A) with an Allen key.
- Tighten the Allen screws (A) with the required tightening torque.

Type	Key size	Tightening torque
BC 2100	17 mm (0.67 in.)	390 Nm (288 ft lbs)
BC 2500	22 mm (0.87 in.)	1500 Nm (1106 ft lbs)
BC 3700	22 mm (0.87 in.)	1500 Nm (1106 ft lbs)
BC 5300	27 mm (1.06 in.)	2300 Nm (1696 ft lbs)

5.4 Attaching the hydraulic attachment to the carrier

5.4.1 Mechanical mounting aspects

You need an assistant to attach the hydraulic attachment to the carrier.

- Agree on hand signals with your assistant, to enable him to help you place the carrier in the proper position to attach the hydraulic attachment.
- Lower the stick of the carrier into the holder provided on the adapter plate.

▲ WARNING Injury by impacts

A sudden movement of the carrier may cause your assistant to be hit and injured by the boom or the hydraulic attachment.

- ▶ Only move the boom very slowly and in a controlled manner while an assistant is within the danger zone.
- ▶ Always keep sight of your assistant.

▲ WARNING Hands and fingers being cut off or hurt

Bores and surfaces can act like a pair of scissors and cut off or hurt parts of your body.

- ▶ Never use your fingers to check bores or fitting surfaces.
- Let your assistant instruct you until the bores in the adapter plate (B) and in the stick (A) are properly aligned.
- Install the stick bolt (C) and lock it.

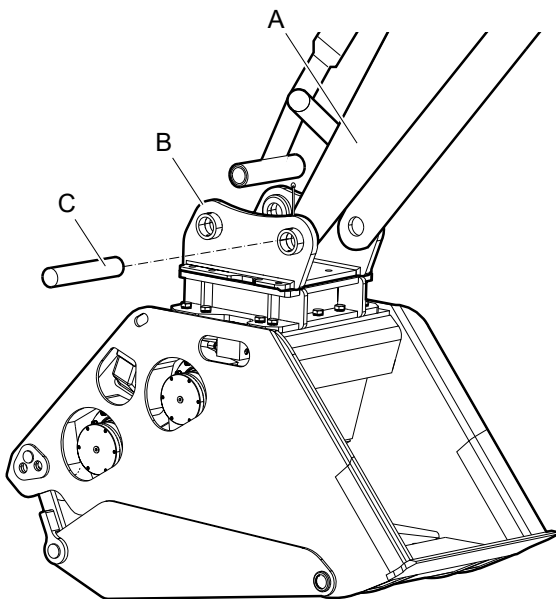

- Extend the bucket cylinder (E) until the bore in the linkage (F) aligns with the bore in the adapter plate (B).

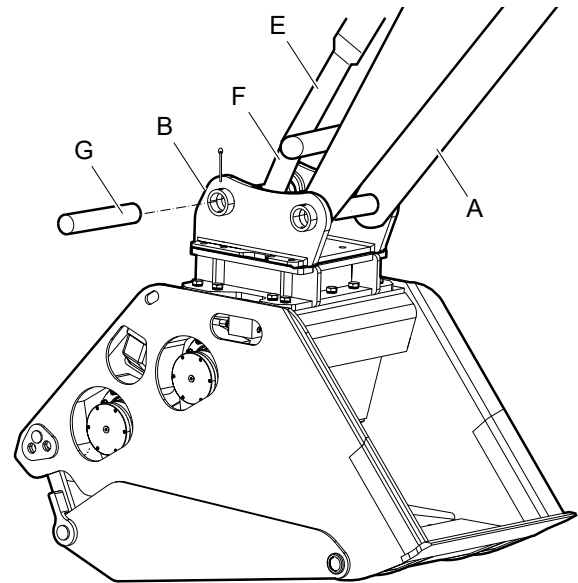

- Install the linkage bolt (G) and lock it.
- Carefully move the bucket cylinder (E) into both end positions.

The adapter plate must not be stopped by the mechanical stops in either position. Consult the Epiroc Customer Center / Dealer in your area if the adapter plate is stopped by a mechanical stop.

5.4.2 First installation / Making the hydraulic connections

▲ **WARNING Risk of death due to defective first installation**

Faults during the first installation or commissioning can lead to life-threatening situations and may cause considerable damage to property.

- ▶ Have the first installation exclusively conducted by authorised specialist personnel.
- ▶ Do not undertake unauthorised first installation.

▲ **WARNING Unexpected movement**

Sudden movements of the carrier may cause serious injury.

- ▶ Secure the carrier such that it cannot move unexpectedly.
- ▶ Observe the carrier manufacturer's instructions.

Before installing the hoses between the bucket crusher and the carrier the hydraulic circuit pressures and flow must be set as follows:

1. Install pressure gauges at the end of the pressure lines on the carrier boom.
2. **Make sure that the carrier circuit is in the "double effect" position (shear or cramp).**
3. Ensure that the shut-off valves at the end of the pressure lines on the carrier boom are in the closed position, to prevent hydraulic flow from reaching the bucket crusher.
4. Start the engine and raise the hydraulic oil temperature to a minimum of 40 °C (104 °F).
5. Operate the bucket crusher control valve with the engine running at full r.p.m. and read the pressure on the gauge on both lines. This pressure is the carrier circuit relief valve setting and should be set at the pressure listed in the following table:

BC 2100, BC 2500, BC 3700

Pressure line static	250 bar (3626 psi)
Pressure line static (unlocked)	150 - 250 bar (5176 - 3626 psi)

BC 5300

Pressure line static	320 bar (4641 psi)
Pressure line static (unlocked)	150 - 250 bar (5176 - 3626 psi)

NOTICE Damage to bucket crusher

Operating the bucket crusher with excessive pressure can possibly lead to serious damage to the hydraulic motor and control valve block cartridge elements.

- ▶ Never operate the bucket crusher with relief valve pressure settings exceeding the values above. The above pressure settings must never be exceeded.
6. Stop the engine. Remove the plugs (or caps) from the shut-off valves and install a flow meter. Open the shut-off valves.
 7. With the carrier at working regime, ensure that the maximum flow never exceeds these values:
with and without flow valve

BC 2100	150 l/min at 40 bar (39.6 gal/min at 580 psi)
BC 2500	175 l/min at 40 bar (46.2 gal/min at 580 psi)
BC 3700	190 l/min at 40 bar (50.2 gal/min at 580 psi)
BC 5300	300 l/min at 40 bar (79.3 gal/min at 580 psi)

8. After ensuring the oil flow is correct, stop the engine, close the shut-off valves and remove the flow meter and hoses.
9. A total of three hoses must be connected from the bucket crusher to the carrier.

NOTICE Faulty hydraulic installation

The carrier must have a suitable hydraulic installation to operate the hydraulic attachment. Improperly installed lines and incorrectly rated sizes may cause the oil to heat up and the hydraulic attachment to be damaged.

- ▶ Only use hydraulic lines of the rated sizes as instructed (see chapter **Technical Specifications**).
 - ▶ Check the rated size of the hydraulic lines on existing hydraulic installations! All supply and return lines for the hydraulic oil must have a sufficient inside diameter and wall thickness.
 - ▶ Route all hydraulic hoses in a torsion-free manner.
10. Switch off the carrier.
 11. Depressurise the hydraulic system according to the manufacturer's safety and operating instructions for the carrier.

12. Close all shut-off valves in the installation at the boom, if no quick couplings are used.

NOTICE Damage to hydraulic parts

Polluted hydraulic lines and connections may enable sand, fragments of material and dirt to penetrate the hydraulic attachment and damage the hydraulic parts.

- ▶ Clean the hydraulic lines and connections prior to connecting the hydraulic lines.
- ▶ Have dirty hydraulic lines rinsed through by a specialist company.
- ▶ Clean dirty hydraulic line connections with a suitable grease-dissolving universal cleaner.
- ▶ Observe the cleaner manufacturer's information on safety and use.

13. Remove the caps/blank flange from the ports and keep them in a safe place.

14. Check that the connections are not damaged.

15. Change any damaged connections.

16. Fit the pressure line (A) to the bucket crusher's connections and the shut-off valve on the carrier in a torsion-free manner.

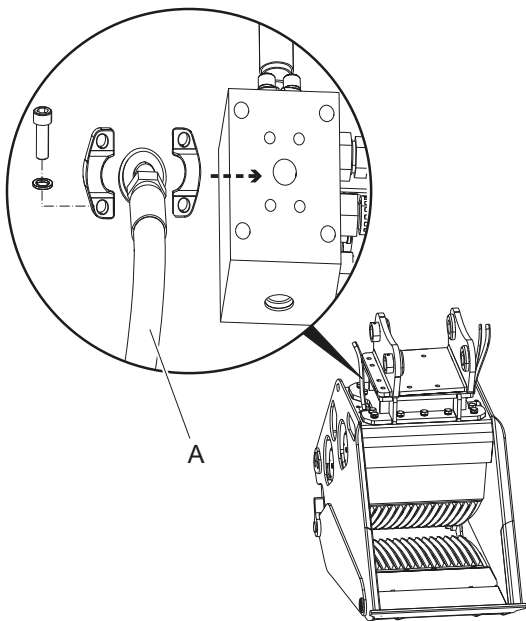

17. Fit the pressure line (C) to the bucket crusher's connections and the shut-off valve on the carrier in a torsion-free manner.

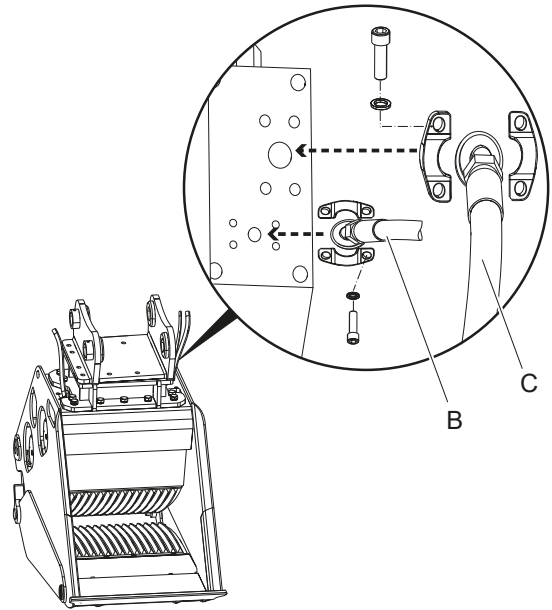

18. Connect the leakage oil line (B) to the bucket crusher and to a connection either on a filter just before the hydraulic tank or directly to the tank.

19. Check the position of the pressure and return hoses.

Installing the hoses on the wrong connections can damage the bucket crusher.

NOTICE Damage due to incorrect installed hydraulic hoses

Incorrectly installed hydraulic hoses can result in severe damage to the hydraulic motor or its seals. The maximum pressure of the leakage oil line is 4 bar.

- ▶ Always install the leakage oil line from the leakage oil line connection on the bucket crusher directly to the hydraulic tank or filter just before the hydraulic tank.
- ▶ Never connect the leakage oil line of the bucket crusher to other drain lines on the carrier. This can lead to excessive back pressure in the bucket crusher's leakage oil line.
- ▶ Install hydraulic hoses such that they always possess sufficient play for turning and rotating motions of the boom.
- ▶ Always check the leakage oil line pressure when mounting the hydraulic attachment to a carrier.

20. Install a pressure gauge in the leakage oil line.

21. Open the oil shut-off keys on the carrier towards the bucket. Start with the pressure line (normally on the right side of the carrier boom but this can differ depending on the carrier's manufacturer, so check which side is the tank side before opening) and then open the pressure line.

22. Start the carrier's engine.
23. Lift the bucket crusher off the ground, idle or run the engine at a low RPM and press the bucket crusher's pedal for about 2 minutes to let the air out of the hydraulic system and at the same time check the system for leaks. If leaks occur, seal them right away.
24. Check the leakage oil line pressure. This pressure should never exceed 4 bar in any case.
25. Stop operating the bucket crusher.
26. Again check the leakage oil line pressure.
This should be at zero.
If there is a pressure this is caused by pressure coming back from the carrier circuit. The cause of this has to be found and rectified (check if the leakage oil line of the bucket crusher is connected to other drain lines from elements on the carrier such as the swing motor or travel motors, if so the leakage oil must be connected directly to the tank or filter just before the tank).
27. If the pressure in leakage oil line of the bucket crusher is correct, lift the bucket crusher and set it in the rest position.
28. Stop the carrier's engine.
29. Remove the pressure gauges fitted in the pressure, tank and leakage oil lines.

5.5 Removing the hydraulic attachment from the carrier

- Place the hydraulic attachment on timber support blocks.

5.5.1 Dismantling the hydraulic connections

▲ **WARNING Unexpected movement**

Sudden movements of the carrier may cause serious injury.

- ▶ Secure the carrier such that it cannot move unexpectedly.
- ▶ Observe the carrier manufacturer's instructions.

▲ **WARNING Hydraulic hose flailing about**

Pressurised hydraulic hoses will flail about when bolted connections have come loose or have been loosened. A hydraulic hose flailing about may cause serious injuries.

- ▶ Depressurise the hydraulic system before disconnecting a hydraulic hose (see chapter **Depressurising the hydraulic system**).

▲ **WARNING Hot parts**

The bucket crusher, hoses, pipes and fittings become very hot during operation. Touching them may lead to burns.

- ▶ Never touch hot parts.
- ▶ If you have to carry out activities where you have to touch the parts, wait for them to cool down first.
- Close all shut-off valves in the installation at the boom if no quick couplings are used.
- Disconnect the hose lines to and from the hydraulic attachment at the boom side.
- Close off all open hose ends.

5.5.2 Mechanical disassembly

- You need an assistant to remove the hydraulic attachment.
- Agree on hand signals with your assistant, to enable him to help you move the boom.

▲ **WARNING Injury by impacts**

A sudden movement of the carrier may cause your assistant to be hit and injured by the boom or the hydraulic attachment.

- ▶ Only move the boom very slowly and in a controlled manner while an assistant is within the danger zone.
- ▶ Always keep sight of your assistant.

▲ **WARNING Metal chips shooting off**

When hammering out bolts, chips may shoot off and cause serious eye injuries.

- ▶ Wear safety glasses when hammering out the bolts.
- Remove the bolt locks from the stick and linkage bolts.
- Drive out the linkage bolt with a steel arbor and a hammer.
- Switch on the carrier.
- Retract the bucket cylinder.

- Drive out the stick bolt with a steel arbor and a hammer.
- Move the carrier stick out of the adapter plate.

5.6 Removing the adapter plate

- Loosen the fastening screws of the adapter plate.
- Lift the adapter plate with a suitable lifting equipment and put it down on timber support blocks.
- Save the fastening screws and the pairs of lock washers for future use.

6 Operation

▲ **WARNING Hot hydraulic oil squirting out**

The hydraulic system is under high pressure. If hydraulic connections come loose, hydraulic oil will squirt out under high pressure. Hydraulic oil squirting out can lead to serious injury.

- ▶ Immediately switch off the hydraulic attachment and the carrier if you detect any leaks in the hydraulic circuits.
- ▶ Depressurise the hydraulic system (see chapter **Depressurising the hydraulic system**).
- ▶ Repair any leaks before operating the hydraulic attachment again.

▲ **WARNING Hot parts**

The bucket crusher, hoses, pipes and fittings become very hot during operation. Touching them may lead to burns.

- ▶ Never touch hot parts.
- ▶ If you have to carry out activities where you have to touch the parts, wait for them to cool down first.

NOTICE Environmental damage due to hydraulic oil

Hydraulic oil is environmentally harmful and must not penetrate the ground or enter the water table or water supplies.

- ▶ Collect any hydraulic oil which escapes.
- ▶ Dispose of it in accordance with the applicable environmental regulations.

NOTICE Hydraulic oil too hot

The temperature of the hydraulic oil must not exceed 80 °C (176 °F). Higher temperature will damage the seals of the hydraulic parts.

- ▶ Monitor the oil temperature.
- ▶ Shut off the hydraulic attachment and the carrier if you measure an increased temperature in the tank.
- ▶ Check the hydraulic installation and the pressure relief valve.

6.1 Preparations before starting

▲ **WARNING Falling carrier**

A carrier falling or tipping over due to the surface not being level may cause serious injury and material damage.

- ▶ Always observe great care when moving the carrier.
- ▶ Do not use the hydraulic attachment until the carrier is positioned stably.

▲ **WARNING Fragments flying around**

Fragments of material which come loose while operating the hydraulic attachment may be flung away and can cause serious injury if people are hit by them. Small objects falling from a great height can also cause serious damage.

During hydraulic attachment operation the danger zone is considerably greater than during the excavation operation due to fragments of stone and pieces of steel flying around, and for this reason the danger zone must, depending on the type of material to be worked on, be enlarged correspondingly, or secured in a suitable manner through corresponding measures.

- ▶ Secure the danger zone of minimum 20 m (66 ft).
- ▶ Stop the hydraulic attachment immediately if anyone enters the danger zone.
- ▶ Close the windscreen and the side windows of the driver's cab.

■ Before starting the bucket crusher, ensure that

- the bucket crusher is complete,
- the bucket crusher and adapter plate do not have any cracks,
- and none of the hydraulic line connections leak.

The preparations required prior to starting the bucket crusher depend on the ambient temperature:

- Ambient temperature below 0 °C (32 °F) (see chapter **Low ambient temperature**).
- Ambient temperature above 30 °C (86 °F) (see chapter **High ambient temperature**).

The oil temperature in the bucket crusher must be between 40 °C (104 °F) and +80 °C (176 °F) during operation.

The full capacity of the bucket crusher can be achieved when the oil temperature is approx. 60 °C (140 °F).

- Make sure that there are no people in the danger zone.
- Start the carrier as instructed by the carrier manufacturer.

- Let the carrier warm up until the operating temperature prescribed by the carrier manufacturer has been reached.
- Put the carrier in its working position.

6.2 Switching the bucket crusher on and off

After properly attaching the hydraulic attachment to the carrier, the hydraulic attachment can be operated using the carrier's hydraulic system. All functions for normal carrier operation remain intact.

The hydraulic attachment is switched on and off using electrical and hydraulic signals.

If you have any questions about electric / hydraulic commands, consult the carrier manufacturer and/or the Epiroc Customer Center / Dealer in your area.

- Switch the hydraulic attachment on and off, as described in the carrier's operating instructions.
- When leaving the driver's cab, set the safety switch / lever for the electrical / hydraulic attachment installation to the „OFF“ position.

Carry out the above actions to prevent any unintended start-up of the hydraulic attachment.

6.3 Functional test

Always carry out a functional test before putting the bucket crusher into use. Check that all hydraulic lines and connections are tight and that the bucket crusher works without any problem.

- Prepare the bucket crusher so that you can start using it (see chapter **Preparations before to starting**).
- Lift the bucket crusher with the carrier boom function and turn it carefully.
- Gradually activate the bucket crusher.
- Observe the hydraulic lines and whether the bucket crusher works properly.
- Switch the bucket crusher off immediately if oil leaks from the hydraulic lines or other malfunctions occur.
- Depressurise the hydraulic system (see chapter **Depressurising the hydraulic system**).
- Only take the bucket crusher back into operation once all leaks or malfunctions have been remedied.

6.4 Correct operation

6.4.1 Filling the bucket crusher

- Fill the bucket crusher with the material to be crushed.

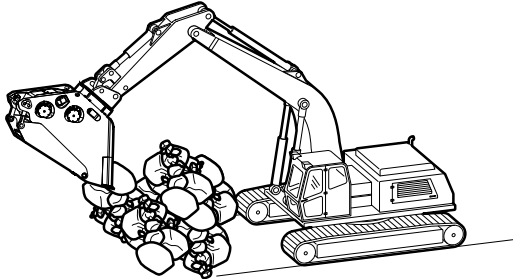

6.4.2 Crushing material

- Rotate the bucket crusher so that the jaw outlet is at the bottom.
- Operate the bucket crusher gradually until the maximum number of revolutions are reached.

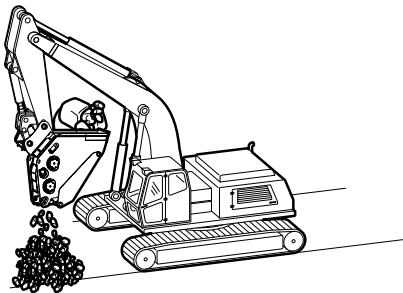

- Once you have completely crushed the material deposited in the bucket crusher, repeat the operation of filling and crushing.

6.4.3 Leveling crushed material

- Rotate the empty bucket crusher to a horizontal position.
- Slightly push crushed material aside to level the ground or clean the working area.

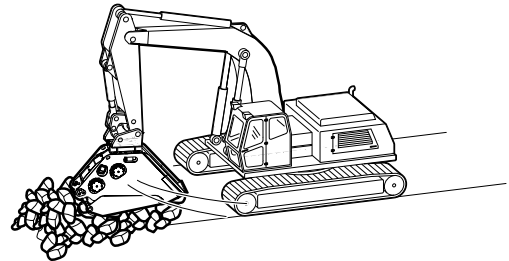

6.4.4 Releasing blocked material

▲ WARNING Parts of the body may be sheared or crushed

The jaws and material may shear or crush parts of the body.

- ▶ Never remove the obstacle manually.
- Stop the bucket crusher.
- Change the direction of movement of the jaws.
- If the jaws are still blocked, rotate the bucket crusher.

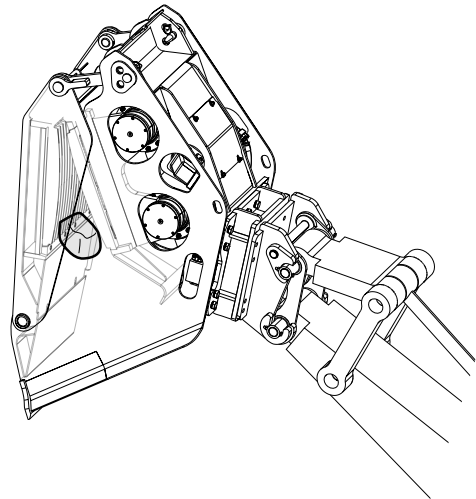

- If necessary, lightly shake the bucket crusher.

6.4.5 Interrupting work

- Place the bucket crusher on its lower support on a horizontal surface.

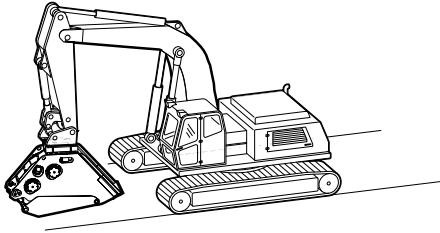

- Secure the carrier that it cannot move unexpectedly.

6.4.6 High ambient temperature

- Only use hydraulic oils of sufficient viscosity.
In summer and in tropical climates, the minimum requirement is a hydraulic oil of type HLP 68.

6.4.7 Low ambient temperature

Ambient temperature below -20 °C (-4 °F):

You must heat up the hydraulic attachment and the carrier when working in ambient temperatures of below -20 °C (-4 °F).

Preferably park the carrier and the hydraulic attachment in a heated, sheltered space while not using it.

NOTICE Hydraulic oil too cold

Operating the hydraulic attachment while hydraulic oil is still cold will damage the seals of the hydraulic parts.

- ▶ Do not operate the bucket crusher until the temperature of the hydraulic oil is at least 40 °C (104 °F).
- Start the carrier as instructed by the carrier manufacturer.
- Let the carrier warm up until the operating temperature required by the manufacturer has been reached.

NOTICE Damage to hydraulic parts

Hot hydraulic oil causes damage to subcooled hydraulic attachments.

- ▶ Do not fill the hydraulic system with hot hydraulic oil.

The temperature of the hydraulic oil of the carrier must be at least 40 °C (104 °F).

- Start the hydraulic attachment, once the temperature has reached 40 °C (104 °F).
- Lift the bucket crusher and gradually start during the warming-up phase.
- During operations, leave the carrier engine and pumps running even during breaks.

6.5 Prohibited operation

6.5.1 Unsafe base

▲ WARNING Danger of tipping

The carrier can topple over and cause injuries and damage.

- ▶ Only work with the hydraulic attachment when the carrier is on a safe base.

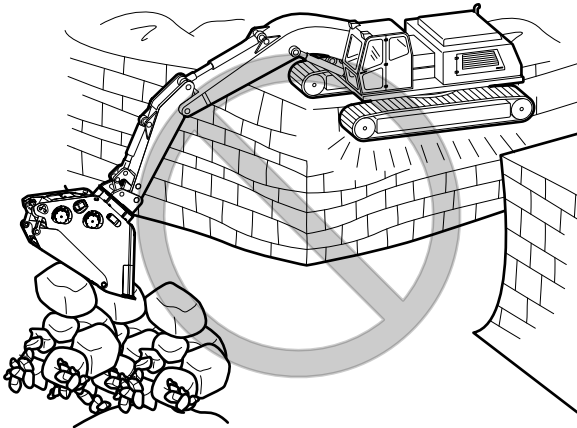

6.5.2 Use over the chain

▲ WARNING Danger of tipping

The carrier can topple over and cause injuries and damage.

- ▶ Never work with full delivery sideways in the direction of movement.

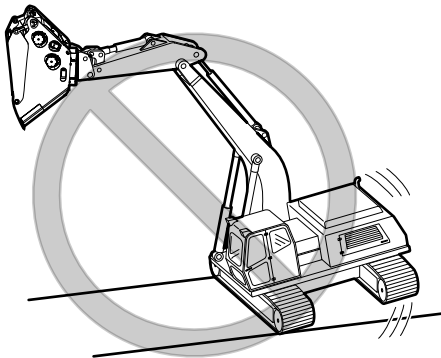

6.5.3 Moving the carrier

- Never relocate the carrier sideways by placing the hydraulic attachment on the ground to lift the carrier. This would seriously damage the hydraulic attachment.

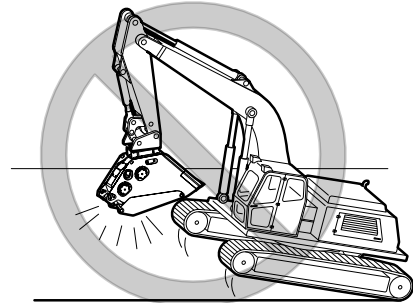

6.5.4 Impacting/chopping

- Do not use the hydraulic attachment to impact or chop to destroy material.

This would seriously damage the hydraulic attachment.

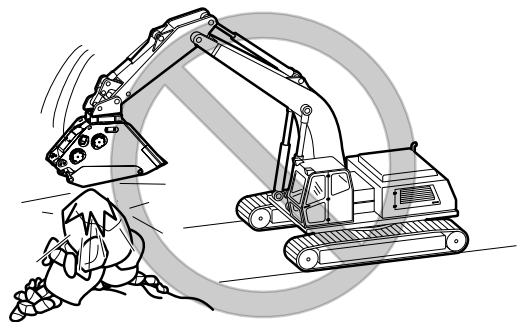

6.5.5 Cylinder end positions

- Reposition the carrier to avoid working with the cylinder in its end positions.

Avoid operating the hydraulic attachment when the carrier stick and bucket cylinder are in one of their end positions. These end positions have damping facilities; the hydraulic cylinder may be damaged by prolonged use while in its end positions.

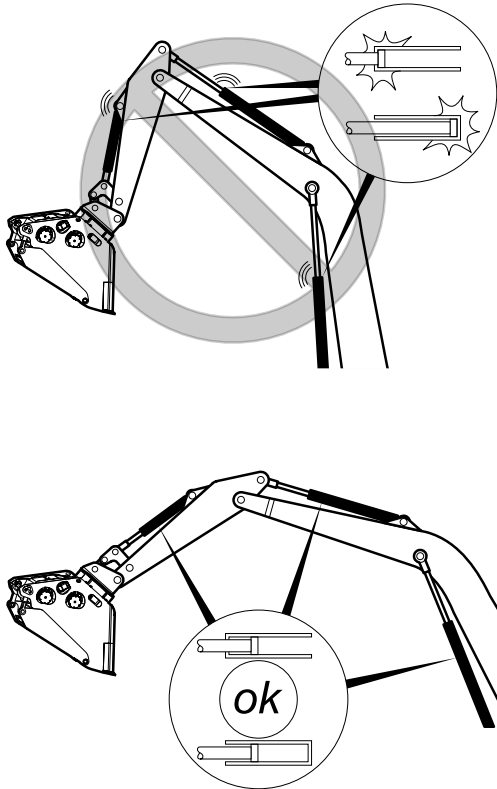

6.5.6 Use under water

- Never use the hydraulic attachment under water. This would seriously damage the hydraulic attachment and may damage the whole hydraulic installation.

6.6 Adjusting the jaw outlet BC 2100

The jaw outlet can easily be adjusted to obtain a crushed product according to the required demands. The adjusting pin is the connection between the lower support and the housing. The adjusting pin is fixed with locking parts. Varying the combination of holes changes the size of the jaw outlet.

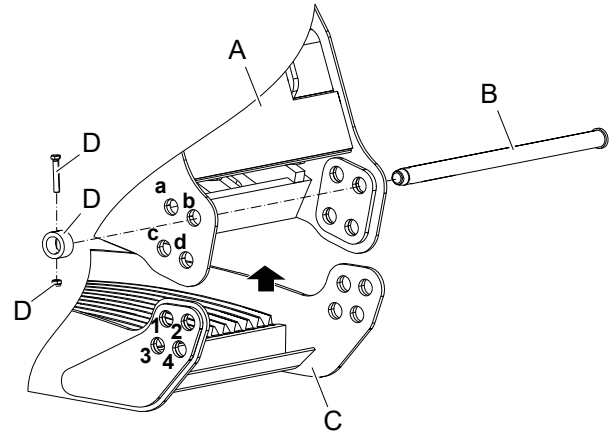

- A. **Housing**
- B. The **adjusting pin** is the connection between the lower support and the housing.
- C. **Lower support**
- D. The **locking parts** (screw, washer, and self-locking nut) fix the adjusting pin.

▲ **WARNING Injury by impacts**

A movement of the carrier may cause an assistant to be hit and injured by the boom or the bucket crusher.

- ▶ Adjusting the jaw outlet has to be done by the carrier driver without assistance of another person.

1. Place the bucket crusher on a horizontal surface without pressure, so that the adjusting pin can be removed without difficulty.
2. Switch off the carrier.

▲ **WARNING Unexpected movement**

Sudden movements of the carrier may cause serious injury.

- ▶ Secure the carrier such that it cannot move unexpectedly.
- ▶ Observe the carrier manufacturer's instructions.
- Remove the locking parts (D) from the adjusting pin (B).

▲ WARNING Hands and fingers being cut off or hurt

Bores and surfaces can act like a pair of scissors and cut off or hurt parts of your body.

- ▶ When removing the adjusting pin (B) there is a risk that the rods may move.
- ▶ Never use your fingers to check bores or fitting surfaces.
- Remove the adjusting pin (B).
- Start the carrier and use it to lift or lower the bucket crusher until the holes match as you want them to.
- Switch off the carrier and lock.
- Visually check the alignment, if necessary repeat the procedure until the holes match.

The holes have to align with an error less than 3 mm.

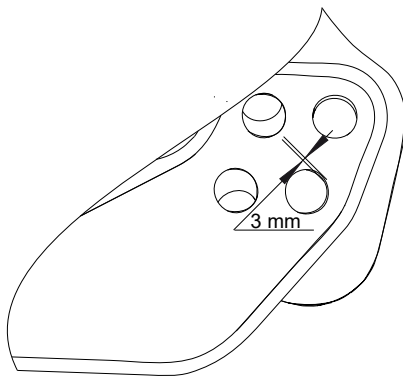

- Clean and slightly grease the adjusting pin (B).
- Place the adjusting pin (B) to fix the selected hole combination, using a hammer if necessary.
- Fix the adjusting pin (B) with the locking parts (D).

Hole combinations from minimum to maximum output size BC 2100

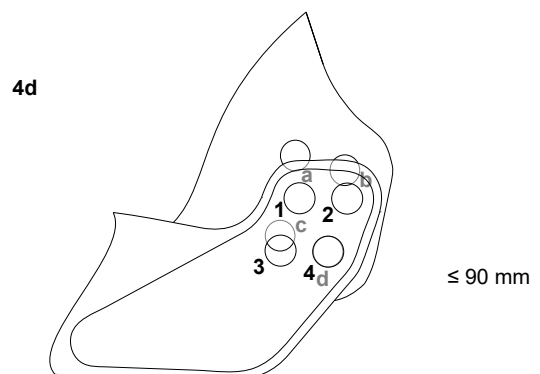
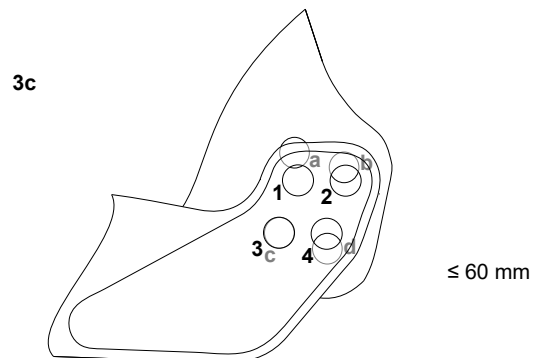
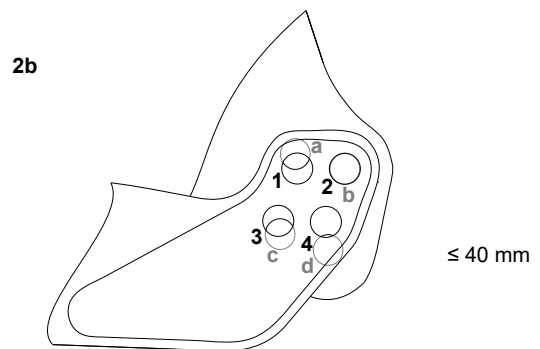
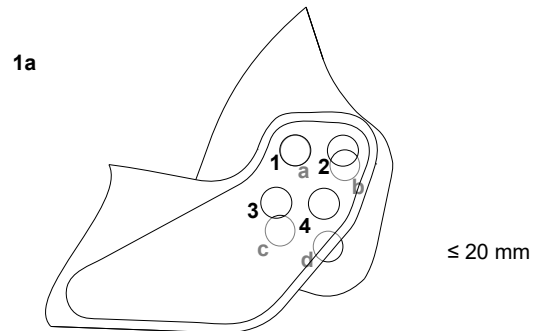

6.7 Adjusting the jaw outlet BC 2500, BC 3700, BC 5300

The jaw outlet can easily be adjusted to obtain a crushed product according to the required demands. The tensioner is the adjustable connection between the lower support and the housing. The tensioner is fixed with bolts. Varying the combination of holes changes the size of the jaw outlet.

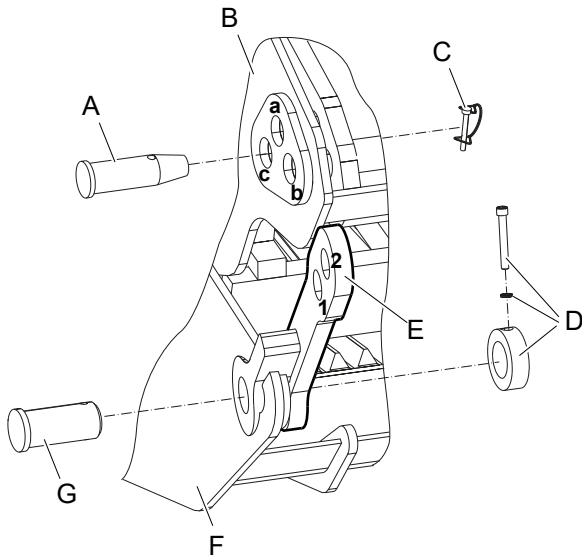

- A. The **upper bolt** fastens the tensioner to the housing.
- B. **Housing**
- C. The **pin** fixes the upper bolt.
- D. The **locking parts** (allen screw, pair of lock washers, screwed washer) fix the lower bolt.
- E. **Tensioner**
- F. **Lower support**
- G. The **lower bolt** fastens the tensioner to the lower support. Only remove the lower bolt when pieces are worn or broken.

▲ WARNING Injury by impacts

A movement of the carrier may cause an assistant to be hit and injured by the boom or the bucket crusher.

- ▶ Adjusting the jaw outlet has to be done by the carrier driver without assistance of another person.
1. Place the bucket crusher on a horizontal surface without pressure, so that the bolts can be removed without difficulty.
 2. Switch off the carrier.

▲ WARNING Unexpected movement

Sudden movements of the carrier may cause serious injury.

- ▶ Secure the carrier such that it cannot move unexpectedly.
- ▶ Observe the carrier manufacturer's instructions.
- Remove the pins (C) from the upper bolts (A).

▲ WARNING Hands and fingers being cut off or hurt

Bores and surfaces can act like a pair of scissors and cut off or hurt parts of your body.

- ▶ When removing the upper bolts (A) there is a risk that the rods may move.
- ▶ Never use your fingers to check bores or fitting surfaces.
- Remove the upper bolts (A), using a hammer if necessary.
- Start the carrier and use it to lift or lower the bucket crusher until the holes match as you want them to.
- Switch off the carrier and lock.
- Visually check the alignment, if necessary repeat the procedure until the holes match.

The holes have to align with an error less than 3 mm.

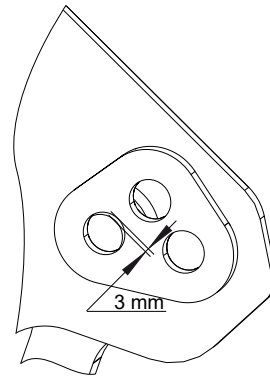

- Clean and slightly grease the upper bolts (A).
- Place the upper bolts (A) to fix the selected hole combination, using a hammer if necessary.
- Fix the upper bolt (A) with the pin (C).

Hole combinations from minimum to maximum output size BC 2500, BC 3700, BC 5300

1a

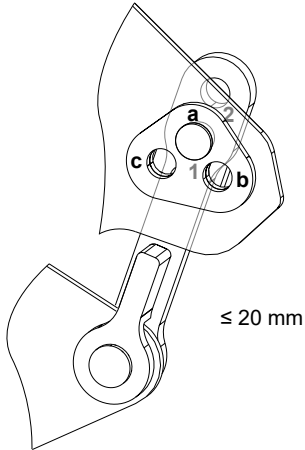

2a

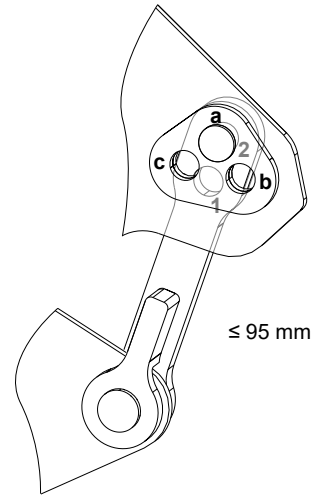

1b

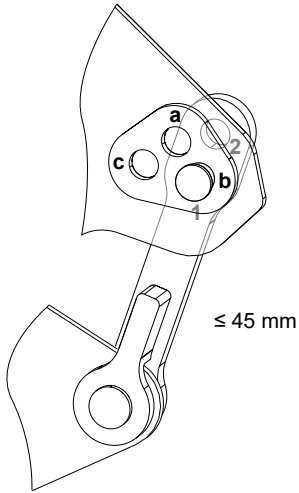

2b

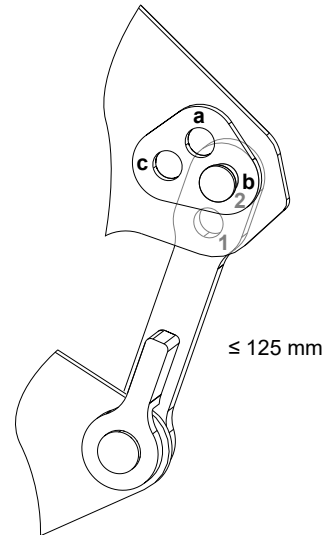

1c

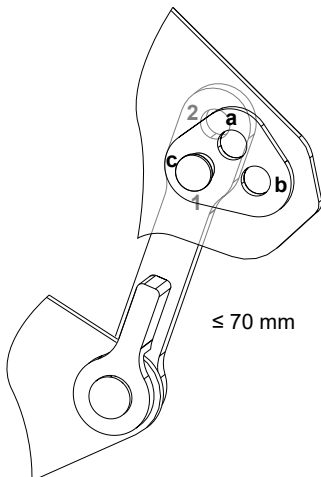

2c

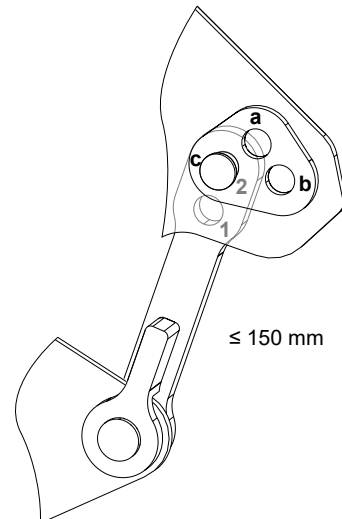

7 Maintenance

The maintenance activities are carried out by the carrier driver.

▲ **WARNING Unexpected movement**

Sudden movements of the carrier may cause serious injury.

- ▶ Turn off the motor of the carrier and remove starter keys.
- ▶ Secure the carrier so that it cannot move unexpectedly.
- ▶ Report with a sign the current maintenance stage.
- ▶ Observe the carrier manufacturer's instructions.

▲ **WARNING Hot hydraulic oil squirting out**

The hydraulic system is under high pressure. Hydraulic oil escaping out can lead to serious injury.

- ▶ Immediately switch off the hydraulic attachment and the carrier if you detect any leaks in the hydraulic circuits.
- ▶ Do not inspect for possible leaks with your fingers or other parts of the body, but use a piece of cardboard instead, holding it up to the suspected leakage site.
- ▶ Examine the cardboard for traces of liquid.
- ▶ Depressurise the hydraulic system (see chapter **Depressurising the hydraulic system**).
- ▶ Repair any leaks before operating the hydraulic attachment again.

▲ **WARNING Hot parts**

The bucket crusher, hoses, pipes and fittings become very hot during operation. Touching them may lead to burns.

- ▶ Never touch hot parts.
- ▶ If you have to carry out activities where you have to touch the parts, wait for them to cool down first.

NOTICE Environmental damage due to hydraulic oil

Hydraulic oil is environmentally harmful and must not penetrate the ground or enter the water table or water supplies.

- ▶ Collect any hydraulic oil which escapes.
- ▶ Dispose of it in accordance with the applicable environmental regulations.

7.1 Maintenance schedule

prior to shift	<p>Fill up grease at all four shaft-pulleys of the eccentric mechanism. The grease must begin to come out from the lower part of the filling hole.</p> <p>Check the bucket crusher and adapter plate for cracks and deformations.</p> <p>Check hydraulic lines for leaks and damage.</p> <p>Check the pipe clamp receiver on the carrier.</p> <p>Check the bolted connections at the adapter plate and tighten as required.</p> <p>Check the bolted connections at the hydraulic lines and tighten as required.</p> <p>Check the hydraulic motors (A) and the control blocks (G) for oil leaks.</p> <p>Check the transmission housing (F) for oil leaks.</p> <p>Check the plugs (B) on the shaft-pulleys and immediately replace if necessary.</p> <p>Check the condition of the tensioner system (C).</p> <p>Check the condition of the wedges (D) and jaws (E).</p> <p>Check the control blocks (G) for grease leakage at the seals.</p> <p>Check warning labels and immediately replace if necessary.</p> <p>During the first 50 operating hours:</p> <p>Check the fixing screws of the wedges (D) and tighten as required.</p> <p>Check the bolts of the tensioner system (C) are in place and proper fixed. Tighten the fixing screws of the lower bolts as required.</p>
During shift (every 2 hours)	<p>Check the lubrication level of the eccentric mechanism every two hours. Fill up grease at all four shaft-pulleys of the eccentric mechanism. Connect the grease gun to the grease nipple and fill up grease until grease begins to come out all around the filling hole.</p>
after the first 50 operating hours	<p>Change hydraulic oil filter cartridge.</p>
every 40 operating hours	<p>Check the fixing screws of the wedges (D) and tighten as required.</p> <p>Check the bolts of the tensioner system (C) are in place and proper fixed. Tighten the fixing screws of the lower bolts as required.</p>
every 200 operating hours	<p>Check oil filter cartridge (drain filter), replace if necessary.</p> <p>Check for traces of rust on the implement.</p>
every 2000 operating hours or 2 years	<p>Replace seals on the control blocks. Strong changes in temperature may damage the seals even in a shorter period of time.</p>
if necessary	<p>Replace fixing screws of the jaws wedges.</p> <p>Replace bent and damaged pipes.</p> <p>Replace damaged hoses.</p>

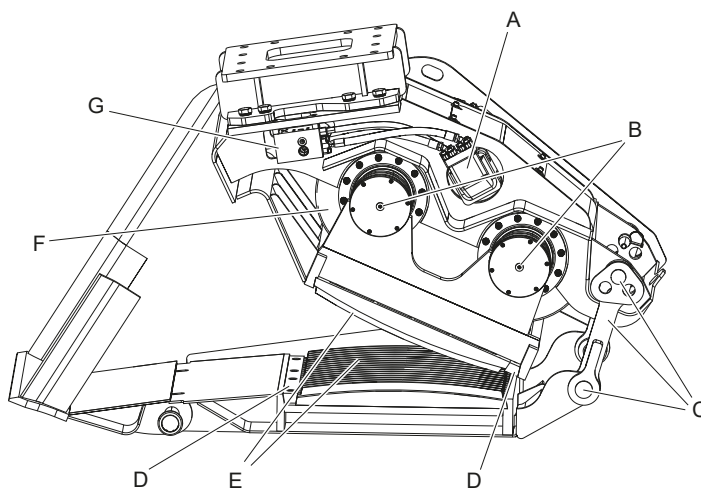

7.2 Depressurising the hydraulic system

Even when you have switched off the carrier, a considerable residual pressure can still be present in the hydraulic system.

A residual pressure can still be present in the hydraulic attachment even after you have disconnected the quick-release couplings or closed the shut-off valves.

The hydraulic attachment can only be depressurized using the hydraulic system of the carrier, by allowing hydraulic oil to drain to the tank via the return connection.

Depending on the type of hydraulic attachment, the internal leaks, the oil temperature, the type of hydraulic oil and the design of the hydraulic installation of the carrier, the time required to relieve the pressure can vary.

Observe the following steps in order to depressurise the hydraulic attachment:

1. Ensure that the hydraulic oil in the hydraulic attachment and in the carrier has a temperature of at least 40 °C. If necessary, pre-heat it to at least 40 °C.
2. The hydraulic attachment must be connected to the hydraulic system of the carrier device, i.e. the hydraulic hoses must be connected up and the respective shut-off valves in the supply pipe and in the connection to the tank must be opened.
3. Place the hydraulic attachment on timber support blocks laying on the ground.
4. Depressurise the hydraulic system according to the manufacturer's safety and operating instructions for the carrier.
5. You must wait at least another 60 minutes until the pressure has been relieved through leakages.
6. When you have made sure that no more pressure is present in the hydraulic system, you must disconnect the hydraulic connection to the carrier. Close the shut-off valves or disconnect the quick-release couplings, so that no hydraulic oil can flow back from the carrier.

7.3 Cleaning

7.3.1 Preparations

NOTICE Damage due to improper cleaning

Directing the high-pressure water jet from a short distance at the more sensitive parts as hydraulic hoses, seals, and other components may damage them.

- ▶ Avoid directing the high-pressure water jet from a short distance at sensitive parts.

Bucket crusher attached:

- Let the bucket crusher hang from the carrier boom. All parts are thus accessible for cleaning.
- Secure the carrier such that it cannot move unexpectedly.

Bucket crusher not attached:

- Plug up all hydraulic ports.

7.3.2 Procedure

- Use a pressure cleaner to remove dirt from the bucket crusher.

7.4 Checking the hydraulic attachment and adapter plate for cracks

- Secure the carrier such that it cannot move unexpectedly.
- Check daily, before and after operation all load-bearing parts and welds of:
 - all the hydraulic attachment,
 - the adapter platefor cracks.
- Ensure repair or refinishing in good time to prevent greater damage.

7.5 Checking hydraulic lines

- Secure the carrier such that it cannot move unexpectedly.
- Perform a visual inspection of all lines (pipes and hoses) from the pump to the hydraulic attachment and back to the tank, before starting work.
- Tighten loose bolted connections and hose clamps to the torque required (see Chapter **Bolted connections / tightening torques**).
- Replace damaged pipes and/or hoses.

7.6 Checking bolted connections

- Secure the carrier such that it cannot move unexpectedly.
- Check all bolted connections regularly for tight fit (see Chapter **Bolted connections / Tightening torques**).
- Tighten loose bolted connections and hose clamps to the torque required (see Chapter **Bolted connections / Tightening torques**).

7.7 Checking and cleaning the hydraulic oil filter of the carrier

An oil filter must be integrated in the return circuit of the hydraulic system. The maximum mesh width allowed for the oil filter is 20 microns; it must have a magnetic separator.

- Secure the carrier such that it cannot move unexpectedly.
- Change the oil filter cartridge after the first 50 operating hours.
- Check the oil filter **every** 500 operating hours and replace it is necessary.

7.8 Greasing the eccentric mechanism

The eccentric mechanism must be greased every 2 operating hours.

▲ WARNING Grease spills

Spilt grease can make a floor slippery. If people slip they can be injured. Grease is environmentally harmful and must not penetrate the ground or enter the water table or water supplies.

- ▶ Make sure not to spill any grease.
- ▶ Immediately clean the floor if you have spilt grease.
- ▶ Observe all safety and environmental protection provisions when handling grease.

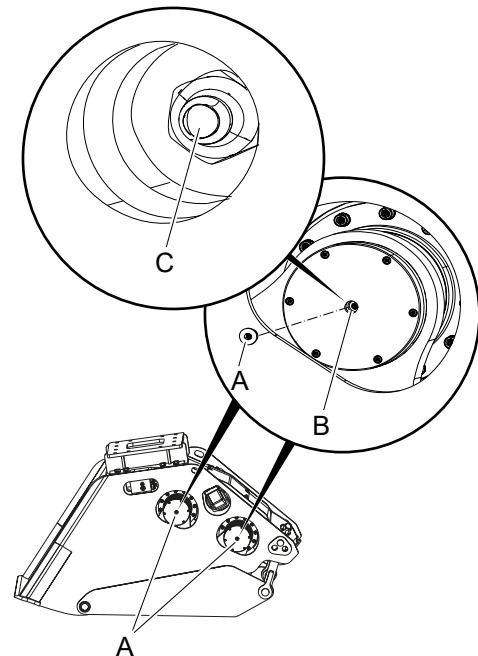

- Remove the plug (A) from the shaft-pulley.
- Clean the filling area (B) around the grease nipple (C).
- Connect the grease gun to the grease nipple and fill up grease until grease begins to come out all around the filling hole.
- Repeat this filling procedure for all four shaft-pulleys.

7.9 Replacing wear parts

Wedge

- Change together with the jaw if the wear of the wedge affects the screw head.

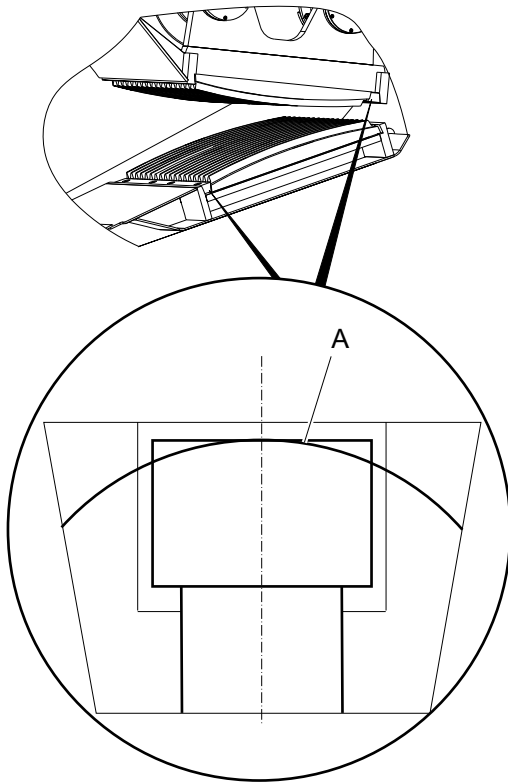

A. Maximum wear zone

Jaw

- Turn the jaws when the rails on the jaw outlet are worn to less than 8 mm (0.03 in.).

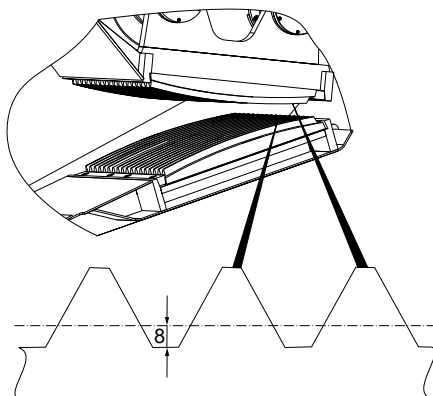

- Change the jaws when the rails are worn on both ends to less than 8 mm (0.03 in.).

BC 2100

▲ WARNING Injury by impacts

A movement of the carrier may cause an assistant to be hit and injured by the boom or the bucket crusher.

- ▶ Removing the adjusting pin has to be done by the carrier driver without assistance of another person.
- Place the bucket crusher on a horizontal surface without pressure, so that the adjusting pin can be removed without difficulty.
- Switch off the carrier.

▲ WARNING Unexpected movement

Sudden movements of the carrier may cause serious injury.

- ▶ Secure the carrier such that it cannot move unexpectedly.
- ▶ Observe the carrier manufacturer's instructions.
- Remove the locking parts (A) from the adjusting pin (B).

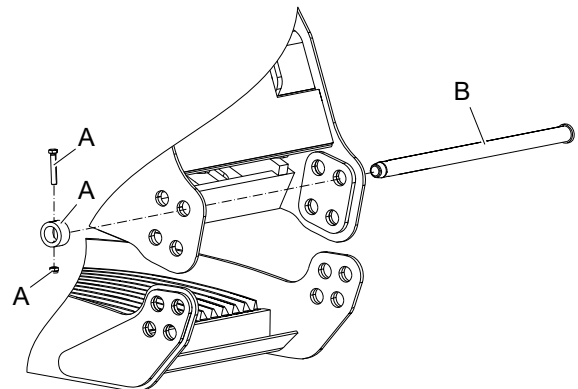

- Remove the adjusting pin (B).

BC 2500, BC 3700, BC 5300

▲ WARNING Injury by impacts

A movement of the carrier may cause an assistant to be hit and injured by the boom or the bucket crusher.

- ▶ Removing the upper bolt of the tensioner system has to be done by the carrier driver without assistance of another person.
- Place the bucket crusher on a horizontal surface without pressure, so that the bolts can be removed without difficulty.
- Switch off the carrier.

▲ WARNING Unexpected movement

Sudden movements of the carrier may cause serious injury.

- ▶ Secure the carrier such that it cannot move unexpectedly.
- ▶ Observe the carrier manufacturer's instructions.
- Remove the pins (B) from the upper bolts (A).

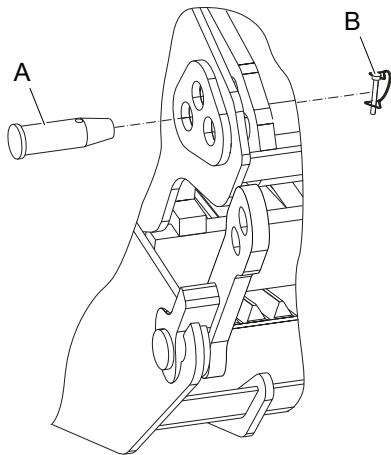

- Remove the upper bolts (A), using a hammer if necessary.

BC 2100, BC 2500, BC 3700, BC 5300

- Start the carrier and use it to lift the bucket crusher until you can easily work on the jaw and the lower support still rests on the ground.



▲ WARNING Hoist tipping over / jaw falling

The jaws are heavy. The hoist/lifting equipment and/or the jaws tipping over or falling may cause serious injury and material damage.

- ▶ Only lift the jaws with lifting equipment with the right load-bearing capacity for their weight.
- ▶ Only lift and secure the jaws with lifting gear (ropes, chains, shackles etc.) with the right load-bearing capacity for the weight to be lifted.
- ▶ Make sure that there is nobody near or under the suspended hydraulic attachment.

Lower jaw

- Remove the screws from the wedge of the lower support.
- Remove the wedge of the lower support.
- Use a hoist to remove the jaw from the lower support.

Upper jaw

- Place the fork of a fork lift truck under the upper jaw to secure it from falling down.
- Remove the screws from the upper wedge.
- Remove the upper wedge.
- Make sure the upper jaw can not topple from the fork.
- Lower the fork of the fork lift truck.

Both jaws

- Turn or replace the jaws and refit.
- Fix the jaws with the wedges.

- Fix the wedge with the screws and tighten with the required tightening torque (see chapter **Bolt connections/Tightening torques**).

7.10 Bolt connections / Tightening torques

The bolt connections of bucket crusher are subjected to very high loads.

- Tighten any loose connections without exceeding the recommended tightening torques.

Connection point	Interval	Type of spanner	Size / Torque		
			BC 2100	BC 2500	BC 3700
Adapter plate* (fastening screws)	A daily	Allen key	17 mm (0.67 in.) 390 Nm (288 ft lbs)	22 mm (0.87 in.) 1500 Nm (1106 ft lbs)	27 mm (1.06 in.) 2300 Nm (1696 ft lbs)
Hydraulic port Leakage oil line	B daily	Allen key	8 mm (0.32 in.) 26 Nm (19 ft lbs)		10 mm (0.39 in.) 49 Nm (36 ft lbs)
Hydraulic port Pressure line	C daily	Allen key	12 mm (0.47 in.) 85 Nm (63 ft lbs)		14 mm (0.55 in.) 135 Nm (100 ft lbs)
Wedge (fastening screws)	D daily during the first 50 and then every 50 operating hours	Allen key	30 mm (1.18 in.) 415 Nm (306 ft lbs)		
Plate (fastening screws)	E daily	socket spanner	41 mm (1.61 in.) 1050 Nm (774 ft lbs)	46 mm (1.81 in.) 1420 Nm (1047 ft lbs)	55 mm (2.17 in.) 2400 Nm (1770 ft lbs)

* Apply anti-seize compound to the allen screw threads before inserting them. The contact faces of the screw head and the lock washers must not be lubricated.

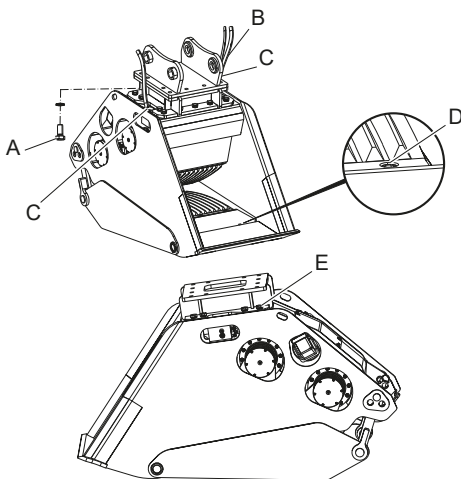

8 Troubleshooting

8.1 Bucket crusher does not work

Cause	Remedy	By
Shut-off valve in pressure line closed	Check and open shut-off valve	Carrier driver
Bucket crusher is connected wrongly	Check the connections	Carrier driver
Motor malfunction	Replace the motor	Workshop
Eccentric mechanism malfunction	Check eccentric mechanism	Epiroc Customer Center / Dealer in your area

8.2 Low impact from the jaws

Cause	Remedy	By
The carrier does not accelerate properly or transfers little power	Accelerate to a suitable rpm	Carrier driver
The operating pressure is below the recommended value	Check the operating pressure at the bucket crusher connection	Carrier driver

8.3 Low crushing productivity

Cause	Remedy	By
Jaws worn out	Replace the jaws	Workshop

8.4 Strange sound during operation

Cause	Remedy	By
Eccentric mechanism malfunction	Check eccentric mechanism	Epiroc Customer Center / Dealer in your area

8.5 Oil escapes at the control blocks

Cause	Remedy	By
Soil or wear on the valve seat surfaces O-ring damaged	Fill up the oil	Epiroc Customer Center / Dealer in your area

8.6 Oil escapes from the transmission housing

Cause	Remedy	By
Defective motor seal ring or damaged seal	Stop immediately	Epiroc Customer Center / Dealer in your area

8.7 Oil escapes at the hydraulic motors

Cause	Remedy	By
Screws or nuts loose	Stop immediately	Epiroc Customer Center / Dealer in your area

8.8 Cracks in the welding of the bucket crusher and/or adapter plate

Cause	Remedy	By
Incorrect use of the bucket crusher	Re-weld cracks	Workshop

9 Repair

▲ **WARNING Hydraulic system under high pressure**

Carrying out repairs on the pressurised hydraulic attachment may lead to serious injury. Connections may come loose unexpectedly, parts may move suddenly and hydraulic oil may squirt out.

- ▶ Depressurise the hydraulic system before carrying out repairs to the hydraulic attachment or the carrier (see chapter **Depressurising the hydraulic system**).
- For technical support contact the Epiroc Customer Center / Dealer in your area.

9.1 Sending in the hydraulic attachment for repairs

NOTICE Mixed hydraulic oil

Never mix mineral and non-mineral hydraulic oils! Even small traces of mineral oil mixed in with non-mineral oil can result in damage to both the hydraulic attachment and the carrier. Non-mineral oil loses its biodegradability.

- ▶ Only use one type of hydraulic oil.
- Always specify which hydraulic oil has been used when sending in the hydraulic attachment to have it repaired.

9.2 Welding

- Only commission qualified welding specialists to perform welding; specialists are people who:
 - have been trained to operate MIG welding equipment according to the national regulations,
 - know all the relevant national/regional safety and accident prevention regulations and
 - who are familiar with and understand these Safety and Operating Instructions.

10 Storage

10.1 Long-term storage

▲ **WARNING** Falling bucket crusher

The bucket crusher is heavy. If it topples over where it is stored, it may cause injury.

- ▶ Place the bucket crusher on its lower support on a pallet and store on a horizontal base.
- Remove the bucket crusher from the carrier (see chapter **Removing the hydraulic attachment from the carrier**).
- Carefully clean and lubricate the bucket crusher.
- Remove rust and paint vulnerable areas.
- Cover all unprotected metal surfaces with a rust inhibitor.
- Store the bucket crusher in a dry, well-ventilated room with a relative air humidity below 60 %.
- Storage temperature: -40 °C (-40 °F) to +80 °C (176 °F).
- If storage is only possible outdoors, then the bucket crusher is to be protected from the weather with plastic film or tarpaulins.

10.2 Hydraulic hoses

The following requirements must be fulfilled for proper storage of hydraulic hoses:

- Cool, dry, dust-free
- Storage temperature: -10 °C to +15 °C, maximum +25 °C
- Avoid direct sunlight
- Shield from direct heat sources (e.g. heating)
- Avoid ozone sources (such as lightning, draft, welding, electric sparking, electric motors, photocopiers)
- Avoid radioactive materials
- Outdoor storage is not permitted without protection from the weather
- Tension-free storage (without tensile or compressive load)
- Avoid contact with substances such as corrosive chemicals, acids, alkalis, solvents etc.

- Avoid insects and rodents.
- The duration of use of hydraulic hoses may not exceed 24 quarters (6 years) from the date of manufacture. The storage period of hydraulic hoses may not exceed two years.

11 Disposal

NOTICE Environmental damage due to hydraulic oil

Hydraulic oil is environmentally harmful and must not penetrate the ground or enter the water table or water supplies.

- ▶ Collect any hydraulic oil which escapes.
- ▶ Dispose of it in accordance with the applicable environmental regulations.

11.1 Bucket crusher

- Remove the bucket crusher from the carrier (see chapter **Removing the hydraulic attachment from the carrier**).
- Remove the adapter plate (see chapter **Removing the adapter plate**).
- Remove the hydraulic hoses from the bucket crusher.
- Clean the bucket crusher (see chapter **Cleaning**).
- Dispose of the bucket crusher in line with all applicable regulations or consult an authorised and specialised recycling company.

11.2 Hydraulic hoses

- Drain the hydraulic oil from the hydraulic hoses and collect it.
- Dispose of the hydraulic hoses in accordance with the applicable regulations to avoid environmental hazards.

11.3 Hydraulic oil

- Collect any hydraulic oil that escapes.
- Dispose of it in accordance with the applicable environmental regulations.

12 Technical specifications

Type	BC 2100	BC 2500	BC 3700	BC 5300
Carrier weight class ¹ with intermediate plate	18 - 28 t (39700-61700 lb)	22 - 30 t (48500-66100 lb)	28 - 38 t (61730-88185 lb)	35 - 54 t (77200-119000 lb)
without intermediate plate	16 - 20 t (35275-44100 lb)	20 - 25 t (44100-55115 lb)	24 - 35 t (52900-77160 lb)	32 - 45 t (70550-99200 lb)
Weight of unit with intermediate plate	2120 kg (4674 lb)	2670 kg (5886 lb)	4000 kg (8819 lb)	5700 kg (12570 lb)
without intermediate plate	2000 kg (4409 lb)	2500 kg (5512 lb)	3760 kg (8289 lb)	5300 kg (11685 lb)
Service weight ² with intermediate plate	2250 kg (4960 lb)	2870 kg (6327 lb)	4290 kg (9458 lb)	6050 kg (13340 lb)
without intermediate plate	2130 kg (4696 lb)	2700 kg (5953 lb)	4050 kg (8929 lb)	5650 kg (12456 lb)
Dimensions				
Length	2046 mm (80.6 in.)	2465 mm (97.0 in.)	2575 mm (101.4 in.)	2829 mm (111.4 in.)
Height	1311 mm (51.6 in.)	1500 mm (59.1 in.)	1600 mm (63.0 in.)	1700 mm (66.9 in.)
Width external	930 mm (36.6 in.)	900 mm (35.4 in.)	1076 mm (42.4 in.)	1285 mm (50.6 in.)
Width internal	730 mm (28.7 in.)	730 mm (28.7 in.)	1076 mm (42.4 in.)	1100 mm (43.3 in.)
Jaw opening	400 mm (15.7 in.)	420 mm (16.5 in.)	900 mm (35.4 in.) 420 mm (16.5 in.)	465 mm (18.3 in.)
Crushing size	20 - 90 mm (0.8 - 3.5 in.)	20 - 140 mm (0.8 - 5.5 in.)		
Loading capacity	0.5 m ³ (0.65 yd ³)	0.8 m ³ (1.05 yd ³)	1 m ³ (1.31 yd ³)	1.2 m ³ (1.57 yd ³)
Operating pressure	250 bar (3626 psi)			320 bar (4641 psi)
Max. leakage oil pressure	4 bar (58 psi)			
Oil flow with and without flow valve at 40 bar (580 psi)	150 l/min (39.6 gal/min)	175 l/min (46.2 gal/min)	190 l/min (50.2 gal/min)	300 l/min (79.3 gal/min)
Hydraulic connections				
Pressure line	SAE 1" 6000 psi			SAE 1¼" 6000 psi
Leakage oil line	SAE ½" 6000 psi			SAE ¾" 6000 psi
Hose lines (inside diameter)				
Pressure line	min. 25 mm / (min. 1")			min. 32 mm / 1¼"
Leakage oil line	min. 12 mm / (min. ½")			min. 19 mm / ¾"
Pipework (diameter and wall thickness)				
Pressure line	min. 30 x 4 mm (min. 1.18 x 0.16 in.)			min. 38 x 5 mm (min. 1.5 x 0.2 in.)
Leakage oil line	min. 15 x 1.5 mm (min. 0.59 x 0.06 in.)			min. 25 x 2 mm (min. 0.47 x 0.08 in.)
Measured sound power level	85 dB(A)			
Hole pattern (group) with intermediate plate	8	9	10	11
without intermediate plate	28	22	23	29

¹ Weight apply to standard carriers only. Any variations must be agreed with Epiroc and / or the carrier manufacturer.

² hydraulic bucket crusher including adapter plate of medium size. Please note that the working weight can be considerably higher, depending on the adapter plate.

12.1 Hydraulic plan control valve block BC 2100, BC 2500, BC 3700

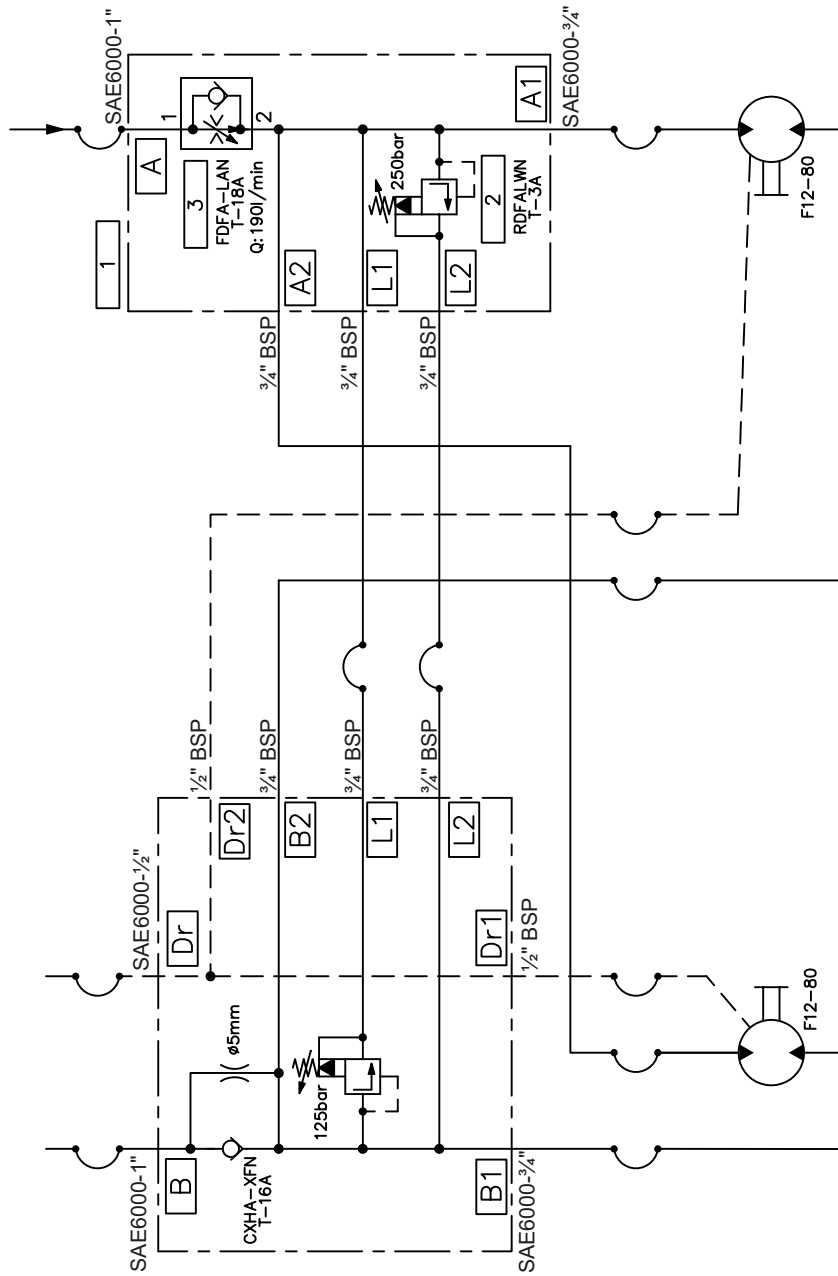

12.2 Hydraulic plan control valve block BC 5300

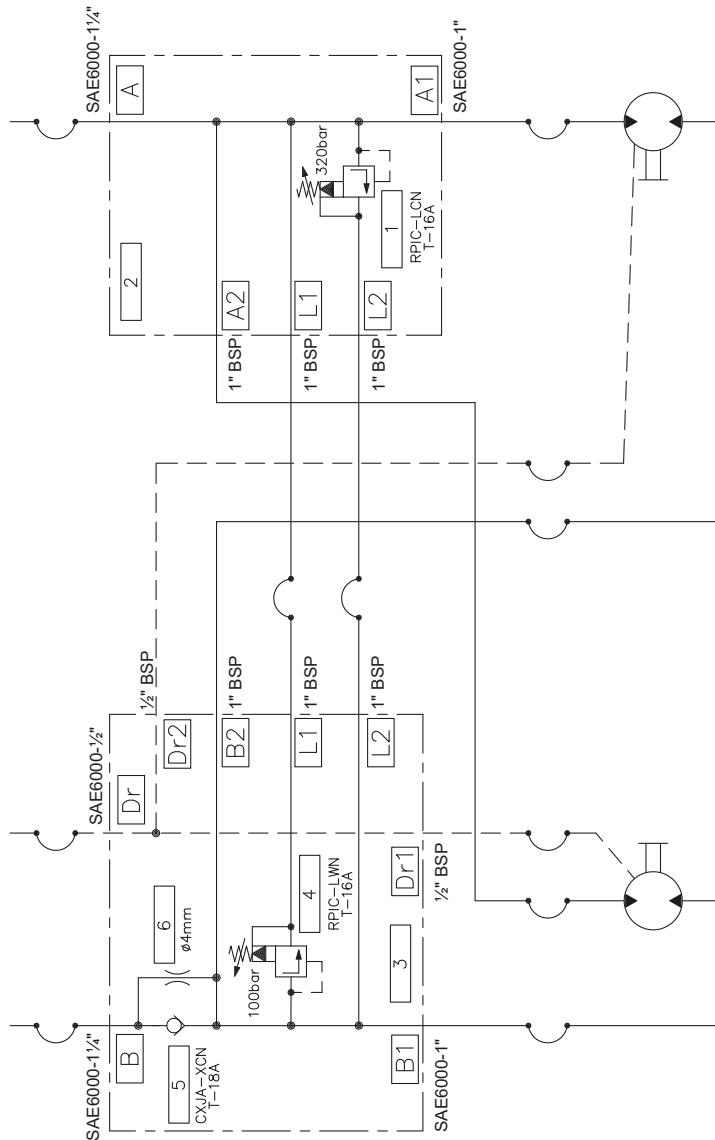

13 EC Declaration of Conformity (EC Directive 2006/42/EC)

We, Construction Tools GmbH, hereby declare that the machines listed below conform to the provisions of EC Directive 2006/42/EC (Machinery Directive), and the harmonised standards mentioned below.

Hydraulic bucket crusher

BC 2100

BC 2500

BC 3700

BC 5300

Following harmonised standards were applied:

- EN ISO 12100
- EN ISO 4413

Technical Documentation authorised representative:

Stephan Schröer
Construction Tools GmbH
45143 Essen
Germany

Authorised Representative:

see respective separate original EC declaration of conformity

Manufacturer:

Construction Tools GmbH
45143 Essen
Germany

Place and date:

Essen, 2019-03-14

Any unauthorized use or copying of the contents or any part thereof is prohibited. This applies in particular to trademarks, model denominations, part numbers, and drawings.

© Construction Tools GmbH | 3390 5170 01 | 2021-04-20