

Safety and operating instructions Transverse Drum Cutters

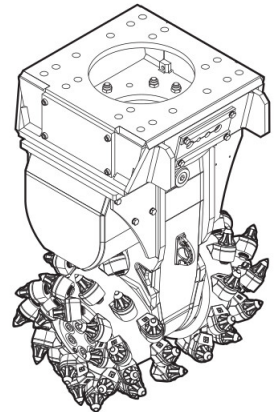

Table of Contents

1	Introduction	7
1.1	About these Safety and Operating Instructions	7
2	Safety instructions	8
2.1	Signal words	8
2.2	Qualification	9
2.3	Intended use	9
2.4	Use other than intended	10
2.5	Protective equipment	10
2.6	Carrier, precautions	10
2.7	Transport, precautions	10
2.8	Hydraulic installation, precautions	11
2.9	Media/consumables, precautions	11
2.10	Explosion and fire, precautions	12
2.11	Electrical shock, precautions	12
2.12	Falling stones, precautions	12
2.13	Emissions, precautions	13
2.14	Handling machines, precautions	13
2.15	Repair, precautions	14
2.15.1	Maintenance works not allowed by the manufacturer	14
2.16	Changes to the hydraulic attachment, precautions	14
2.17	Environmental pollution, precautions	14
3	Overview	15
3.1	Equipment description	15
3.2	Function	15
3.3	Modules	15
3.4	Signs / labels	17
3.4.1	Signs	17
3.4.2	Name plate	17
3.4.3	Labels	18
3.5	Applications	18
3.6	Working area and hazardous area	18
3.7	Removing the packaging	19
3.8	Scope of delivery	19
3.9	Standard round attack picks	20
3.10	Tools for round attack picks	20
4	Transport	21
4.1	Transport using a crane	21
4.2	Transport using a forklift truck	22
4.3	Transport using a truck	22
5	Installation	23

5.1 Media/consumables	23
5.1.1 Mineral hydraulic oil.....	23
5.1.2 Non-mineral hydraulic oil.....	23
5.1.3 Gear oil.....	24
5.2 Preconditions for the carrier	24
5.3 Preconditions for adapter plate	24
5.4 Attaching the hydraulic attachment to the carrier	25
5.4.1 Mechanical mounting aspects	25
5.4.2 First installation	26
5.4.3 Making the hydraulic connections	27
5.5 Removing the hydraulic attachment from the carrier	28
6 Operation	30
6.1 Preparations before starting	31
6.1.1 Ambient temperature	31
6.2 Commissioning	32
6.2.1 Checks during commissioning.....	32
6.3 Switching the drum cutter on and off	32
6.4 Functional test	33
6.5 Correct operation	33
6.6 Prohibited operation	34
6.6.1 Cylinder end positions	34
6.6.2 Moving the carrier.....	35
6.6.3 Lifting/Transporting.....	35
6.6.4 Impacting/chopping	35
6.7 Activities after use	35
6.8 Turning the drum cutter	36
7 Maintenance	37
7.1 Maintenance works not allowed by the manufacturer	38
7.2 Maintenance schedule	39
7.3 Depressurising the hydraulic system	40
7.4 Cleaning	40
7.5 Checking bolted connections	41
7.6 Checking the hydraulic attachment and adapter plate for cracks	41
7.7 Checking the adapter plate bolts for wear	41
7.8 Change gear oil	41
7.8.1 Oil change intervals.....	41
7.8.2 Preparation.....	42
7.8.3 Drain off gear oil.....	42
7.8.4 Fill up gear oil.....	42
7.9 Check the round attack picks and pick boxes	43
7.10 Replace round attack picks	43
7.10.1 Replace round attack pick with knock on retainer	44
7.10.2 Replace round attack pick with retaining sleeve	45
7.10.3 Replace round attack picks with quick snap retainer	46
7.10.4 Replace round attack picks with retaining ring.....	47
7.11 Replace cutter drums	48
7.11.1 Disassemble cutter drums.....	48
7.11.2 Assemble cutter drums.....	49

7.12 Assemble and disassemble intermediate bracket.....	50
7.12.1 Disassemble intermediate bracket	50
7.12.2 Assemble intermediate bracket.....	51
7.13 Assemble and disassemble rotatable upper part.....	52
7.13.1 Disassemble rotatable upper part	52
7.13.2 Assemble rotatable upper part	53
7.14 Checking hydraulic lines	54
7.15 Checking and cleaning the hydraulic oil filter of the carrier	54
7.16 Replace hydraulic hoses.....	54
7.17 Actions following maintenance.....	55
7.18 Bolt connections / Tightening torques	56
8 Troubleshooting	57
8.1 Faults table.....	57
8.2 Cutter drums do not turn / are blocked	58
8.3 Cutter drums turn too slowly.....	58
8.4 Drum cutter stops moving with light pressure	59
8.5 Unusual oscillation of the cutter drums	59
8.6 Round attack picks do not turn.....	59
8.7 Unusually loud gear noise	59
8.8 Unusually loud noise from the hydraulic motor	59
8.9 Overpressure cover for the hydraulic motor deformed, oil leak on sealing surface, oil leak at the pressure limiting valve	60
8.10 Oil leaking at the cutter drum area.....	60
8.11 Behaviour following fault elimination.....	60
9 Repair.....	61
9.1 Sending in the hydraulic attachment for repairs	61
10 Storage	62
10.1 Drum cutter	62
10.1.1 Short storage.....	62
10.1.2 Long storage	62
10.2 Cutter drums	62
10.3 Round attack picks.....	62
11 Disposal.....	63
11.1 Drum cutter	63
11.2 Hydraulic hoses	63
11.3 Hydraulic oil	63
11.4 Gear oil	63
12 Technical specifications	64
13 Appendix	67
13.1 Hydraulic installation version 1 for hydraulic hammer	67
13.2 Hydraulic installation version 2 for hydraulic shear systems	68
13.3 Hydraulic settings (explanation for following diagrams).....	69

13.4 Hydraulic settings VC 1400.....	70
13.5 Hydraulic settings VC 2000.....	72
13.6 Hydraulic settings VC 3000.....	74
14 EC Declaration of Conformity (EC Directive 2006/42/EC)	76

1 Introduction

Epiroc was able to expand its Construction Engineering division in January 2017 with the incorporation of the company Erkat. The wellknown brand in the industry for over 18 years remains unchanged. Erkat offers robust special cutting units for excavators and skid-steer loaders, which are manufactured to the highest quality standards in Germany. Epiroc – a world-renowned company in the construction industry - is expanding its range successfully with high-quality transverse and longitudinal drum cutters for demolition, trenching, tunnelling and rock excavation.

Construction Tools GmbH

Hämbacher Str. 5

D - 36466 Dermbach OT Stadtlengsfeld

Tel.: +49 3695 851 09 0

Fax: +49 3695 851 0999

1.1 About these Safety and Operating Instructions



The aim of these Instructions is to familiarise you with the safe and effective operation of the hydraulic attachment. You will also find instructions for regular maintenance activities for the hydraulic attachment in this document.

Please read these Instructions carefully prior to the first attachment and use of the hydraulic attachment.



The different designation of the texts means as follows:

▶	Action step in a safety instruction
◆	Action step
1. 2.	Established operation process
A B C	Explanation of the elements of a drawing
• • •	Listing

Symbols used in illustrations have the following meanings:

	permitted operation
	prohibited operation

2 Safety instructions

	This is the safety alert symbol. It is used to alert you to potential personal injury hazards. Obey all safety messages that follow this symbol to avoid possible injury or death.
	Read these Safety and operating instructions and specifically all safety instructions before using the hydraulic attachment. This will: <ul style="list-style-type: none"> • prevent the risk of injuries and fatal accidents for yourself and others, • protect the environment against environmental damage. • protect the hydraulic attachment and other property against material damage,

Follow all instructions in these Safety and operating instructions.

Store these Safety and operating instructions in the document compartment of the carrier cab.

Anyone

- transporting,
- installing or removing,
- operating,
- maintaining,
- repairing,
- storing or
- disposing of

the hydraulic attachment must have read and understood these Safety and operating instructions.

These Safety and operating instructions belong to the hydraulic attachment. Keep it for the life of the product. Ensure, if applicable, that any received amendment is incorporated in the instructions. Hand over the Safety and operating instructions if ever you lend, rent out or sell the hydraulic attachment.

All safety regulations listed in this manual comply with the laws and regulations of the European Union. Also observe the additional national/regional regulations.

Hydraulic attachment operation outside the European Union is subject to the laws and regulations valid in the country of use. Please observe any other, more stringent regional regulations and legislation.

Read the carrier manufacturer's Safety and operating Instructions before attaching the hydraulic attachment to the carrier and operating it. Observe all instructions.

2.1 Signal words

The signal words Danger, Warning, Caution, and Notice are used as follows in these Safety and operating instructions:

DANGER	indicates a hazardous situation which, if not avoided, will result in death or serious injury.
WARNING	indicates a hazardous situation which, if not avoided, could result in death or serious injury.
CAUTION	indicates a hazardous situation which, if not avoided, could result in minor or moderate injury.
NOTICE	The signal word NOTICE is used to address practices related to possible property damage but not related to personal injury.

2.2 Qualification

Transporting the hydraulic attachment is only permitted if carried out by people who:

- are authorised to operate a crane or a forklift truck according to the applicable national provisions,
- know all the relevant national/regional safety provisions and accident prevention rules,
- have read and understood the safety and transport chapter of these Safety and operating instructions.

First installation and commissioning of the hydraulic attachment is only permitted if carried out by people who:

- are authorised by Construction Tools GmbH,
- know all the relevant national/regional safety provisions and accident prevention rules,
- have read and understood these Safety and operating instructions.

Installing, maintaining, storing and disposing of the hydraulic attachment are only permitted if carried out by people who:

- know all the relevant national/regional safety provisions and accident prevention rules,
- have read and understood these Safety and operating instructions.

Operating the hydraulic attachment is only permitted if carried out by qualified carrier drivers. Carrier drivers are qualified if they:

- have been trained to operate a carrier according to the national regulations,
- know all the relevant national/regional safety provisions and accident prevention rules,
- have read and understood these Safety and operating instructions.

Testing the hydraulic installation is only permitted if carried out by professionals. Professionals are people who are authorised to approve a hydraulic installation for operation according to the national regulations.

Repairing the hydraulic attachment is only permitted if carried out by professionals trained by Construction Tools GmbH. These professionals must have read and understood these Safety and operating instructions. They must follow all safety instructions and guidelines for repair. Otherwise the operational safety of the hydraulic attachment is not guaranteed.

Personnel (carrier operator, maintenance personnel) must receive instructions from the operator regularly. For the purpose of improved traceability, the provision of instructions must be recorded.

2.3 Intended use

Only attach the drum cutter to a hydraulic carrier of a suitable load-bearing capacity. Read the carrier manufacturer's Safety and operating instructions before attaching the drum cutter to the carrier and operating it. Observe all instructions.

The drum cutter is intended exclusively for mounting on a hydraulic excavator or, following agreement with the authorized Customer Center / dealer in your area, with another carrier.

The drum cutter serves exclusively to cut:

- Rock
- Concrete (reinforced and non-reinforced)

Prior to carrying out cutting work on reinforced concrete, discuss this with the manufacturer (Construction Tools GmbH).

- Asphalt
- Frozen soil
- Ice

Furthermore, the drum cutter is suitable for cutting ditches and tunnels and for mixing soil structures. The drum cutter can be used to a depth of 30 m (99 ft) under water. Contact the authorized Customer Center / dealer in your area if bigger water depth is required.

A drum cutter equipped with HATCON can be used to a depth of 4 m (13 ft) under water. Contact the authorized Customer Center / dealer in your area.

When cutting with the drum cutter, check the compressive strengths of the rock to be cut (see chapter **Technical specifications**).

Intended use also includes adhering to all specifications contained in this manual.

Any further use which exceeds or is contrary to the intended use is considered inappropriate use.

2.4 Use other than intended

Misusing the drum cutter or the boom can lead to dangerous situations.

- Do not use the drum cutter in areas with a risk for explosions.
- Do not cut any materials other than those mentioned in chapter **Intended use**.
- Do not carry out any impacting work.
- Do not operate the drum cutter if picks are broken.
- Do not use the drum cutter as a device for lifting people or materials.
- Do not use the drum cutter as a surface for carrying or transporting machines, materials or tools.
- Do not use the drum cutter to take the weight of the carrier.

Claims of any kind as a result of damages arising from misuse are excluded.

2.5 Protective equipment

Personal protective equipment must comply with the applicable health and safety regulations.

Always wear the following personal protective equipment:

- protective helmet
- safety glasses with side protectors
- protective gloves
- protective shoes
- warning vest
- Light respiratory protection
- Protective work clothing

Protective work clothing is tight-fitting work clothing with low resistance to tearing, with tight sleeves and without projecting parts. It is primarily used to protect against entanglement by moving machine parts. Do not wear rings, chains or other jewellery.

2.6 Carrier, precautions

▲ **WARNING Falling carrier**

If the load-bearing capacity of the carrier used is insufficient, the carrier will not be stable. It can topple over and cause injuries and damage.

Using a carrier whose load-bearing capacity is too high will greatly burden the hydraulic attachment causing it to wear faster.

- ▶ Only attach the hydraulic attachment to a hydraulic carrier of a suitable load-bearing capacity.
- ▶ The carrier must remain stable at all times.
- ▶ Read the carrier manufacturer's Safety and operating Instructions before attaching the hydraulic attachment to the carrier and operating it. Observe all instructions.

NOTICE Damage to the hydraulic attachment

Working with a hydraulic attachment mounted to a long reach boom may cause damage to the hydraulic attachment.

- ▶ Before working with a hydraulic attachment mounted to a long reach boom consult the authorized Customer Center / Dealer in your area.

2.7 Transport, precautions

▲ **WARNING Risk of death due to suspended loads**

When lifting loads these can swing out and fall. This can result in serious injuries or even death.

- ▶ Never stand underneath or in the swinging range of suspended loads.
- ▶ Only move loads under supervision.
- ▶ Only use approved lifting equipment and lifting gear with sufficient load bearing capacity.
- ▶ Do not use worn lifting gear (ropes, belts, chains, shackles etc.).
- ▶ Do not place lifting gear such as ropes and belts on sharp edges or corners, do not knot these or twist them.
- ▶ When leaving the workplace, set down the load.

▲ **WARNING Injury due to swivelling load**

When transporting the load by crane it can swivel and cause severe injuries and considerable damage to property.

- ▶ Ensure that no personnel, objects or obstacles are located in the swivel range of the load.

2.8 Hydraulic installation, precautions

▲ WARNING Hydraulic pressure too high

If the hydraulic pressure is too high, the parts of the hydraulic attachment will be exposed to excessively high loads. Parts can break loose or burst causing serious injuries.

- ▶ Lay the drain line of the pressure relief valve directly in the tank to ensure the safe functioning of the pressure relief valve!
- ▶ The pressure relief valve must be set at the maximum static pressure.
- ▶ The pressure relief valve setting must be checked to ensure that the maximum static pressure (see chapter **Technical specifications**) of the hydraulic installation is not exceeded at any time. Attach a lead seal to the pressure relief valve.
- ▶ Prior to their first use, the safety facilities on the hydraulic installation must be checked by a professional/authorised monitoring body for their quality (CE mark etc.), suitability and proper functioning.
- ▶ If any significant changes are made to the hydraulic installation, a new acceptance inspection is to be carried out in accordance with the relevant national safety provisions.

▲ WARNING Hot hydraulic oil squirting out

The hydraulic system is under high pressure. Hydraulic lines may spring a leak or burst. Hydraulic oil squirting out can lead to serious injury.

- ▶ When attaching the hydraulic attachment do not route any hydraulic lines through the carrier's cab.
- ▶ Only use hydraulic lines which comply with the following quality requirements: Hydraulic hoses with 4 reinforcement steel wires 4SP and 4SH according to DIN EN 856, Hydraulic hoses with high tensile steel wire braid 1SN and 2SN according to DIN EN 853, Hydraulic pipes, seamless cold-drawn steel pipes to DIN EN 10305.

2.9 Media/consumables, precautions

▲ WARNING Hot hydraulic oil under high pressure

Hydraulic oil will squirt out under high pressure if there is a leakage. The jet of oil might penetrate people's skin and cause permanent damage. Hot hydraulic oil can cause burns.

- ▶ Never use your hands to find leaks.
- ▶ Always keep your face away from a possible leak.
- ▶ If hydraulic oil has penetrated your skin consult a doctor immediately.

▲ WARNING Hydraulic oil spills

Spilt hydraulic oil can make a floor slippery. If people slip they can be injured. Hydraulic oil is environmentally harmful and must not penetrate the ground or enter the water table or water supplies.

- ▶ Make sure not to spill any hydraulic oil.
- ▶ Immediately clean the floor if you have spilt hydraulic oil.
- ▶ Observe all safety and environmental protection provisions when handling hydraulic oil.

▲ WARNING Skin infections/diseases due to oil and grease

Hydraulic oil and grease can cause rashes (or even eczema) if they come into contact with the skin.

- ▶ Avoid all skin contact with hydraulic oil and grease.
- ▶ Use a suitable skin protection product.
- ▶ Always wear safety gloves when working with hydraulic oil or grease.
- ▶ Immediately clean any skin that has been contaminated by oil or grease with water and soap.

2.10 Explosion and fire, precautions

▲ DANGER Explosion and fire

Explosions cause serious injury or death.

If the hydraulic attachment encounters explosives in operation, it may cause an explosion.

- ▶ Never operate the hydraulic attachment in the direct vicinity of explosives.
- ▶ Make sure that no explosives are hidden in the ground.
- ▶ Check gas line position plans of the complete construction area.

▲ DANGER Explosion and fire

Operating the hydraulic attachment may create sparks which ignite highly flammable gases.

This may lead to fire or an explosion.

- ▶ Never work in an environment with highly flammable substances.
- ▶ Make sure that there are no hidden sources of gas in the work area.
- ▶ Check gas line position plans of the complete construction area.

▲ DANGER Explosion and fire

Dust-rich air can form an explosive atmosphere which may ignite when operating the hydraulic attachment.

This may lead to fire or an explosion.

- ▶ Never operate the hydraulic attachment in an explosion-hazard atmosphere.
- ▶ Always provide sufficient ventilation when working in buildings or in a confined area.

▲ WARNING Risk of explosion

If the hydraulic attachment is equipped with HATCON explosion may occur when the contained lithium batteries are penetrated by pieces of steel or reinforcing bars.

- ▶ Avoid impact of reinforcement, flying rocks or even explosives on HATCON.
- ▶ Check the HATCON before operating.

2.11 Electrical shock, precautions

▲ DANGER Electrical shock

Any contact of the hydraulic attachment with electric circuits or other sources of electricity will lead to an electric shock, resulting in serious injury or death. The hydraulic attachment is not electrically insulated.

- ▶ Never work in the vicinity of electric circuits or other sources of electricity.
- ▶ Make sure that there are no hidden circuits in the work area.
- ▶ Check wiring diagrams.

2.12 Falling stones, precautions

▲ DANGER Fragments flying around

Fragments of material which come loose while operating the hydraulic attachment may be flung away and can cause serious injury if people are hit by them. Small objects falling from a great height can also cause serious damage.

During hydraulic attachment operation the danger zone is considerably greater than during the excavation operation due to fragments of stone and pieces of steel flying around, and for this reason the danger zone must, depending on the type of material to be worked on, be enlarged correspondingly, or secured in a suitable manner through corresponding measures.

- ▶ Secure the danger zone.
- ▶ Ensure that no persons are within a distance of 15 m (50 ft) during cutting work.
- ▶ Ensure that no persons are within a distance of 50 m (165 ft) during cutting work on reinforced steel.
- ▶ Stop the hydraulic attachment immediately if anyone enters the danger zone.
- ▶ Close the windscreen and the side windows of the driver's cab.
- ▶ The cabin of the hydraulic carrier must be protected by means of suitable measures (e.g. armoured glass, min. class P4A according to DIN EN 356) against damage due to flying rock.
- ▶ Make sure no flying fragments can leave the danger zone (e.g. safety fence).

2.13 Emissions, precautions

▲ WARNING Noise hazard

Operating the hydraulic attachment creates a loud noise. Long term high sound pressure level can affect your hearing.

- ▶ Wear suitable hearing protection.

▲ WARNING Lung disease

Dust may be generated when operating the hydraulic attachment. If dust from rocks or silica dust, produced when operating the hydraulic attachment on rocks, concrete, asphalt or other such materials, is inhaled this may lead to silicosis (dust lungs, a severe lung disease). Silicosis is a chronic disease which may lead cancer and death.

- ▶ Wear a suitable breathing mask.

▲ WARNING Vibration hazards

When working with the drum cutter severe vibrations can occur and may cause considerable significant injuries and chronic damage to health.

- ▶ Operate the drum cutter with a constant load, in order to minimise existing vibrations.
- ▶ Avoid abrupt starting up or stopping of the cutter drums.

▲ WARNING Risk of death if exhaust gases are not vented

When working in buildings or tunnels, exhaust gases from the carrier (diesel motor) can collect and cause poisoning or even death.

- ▶ Effectively vent exhaust gases from buildings or tunnels using a ventilation system.
- ▶ Keep the cabin doors of the carrier closed.

▲ WARNING Hot surfaces

The cutter drums of the drum cutter can become very hot in operation. Skin contact with hot surfaces results in severe burns to the skin.

- ▶ Always wear heat-resistant protective work clothes and protective gloves, when working in close proximity to hot surfaces.
- ▶ Prior to all work, check the drum cutter to ensure that all surfaces have cooled to the ambient temperature.

2.14 Handling machines, precautions

▲ WARNING Injuries due to incorrect operation

Incorrect operation can result in severe injuries and may cause considerable damage to property.

- ▶ Carry out all operating steps in accordance with these Safety and operating instructions.
- ▶ Prior to starting work, ensure that:
 - All covers and safety devices are installed and are fully functional.
 - No persons are in the hazardous area.
- ▶ Never switch off any safety devices during operations or bridge these.

▲ WARNING Injuries due to unclean workplace

A dirty workplace can cause accidents and may result in severe injuries.

- ▶ Always keep the accesses to the carrier cabin clean.
- ▶ Always keep the cabin windows clean.
- ▶ Do not leave parts or objects lying around the working area.

▲ WARNING Injuries due to missed inspection and repair work

Disregarding or neglecting daily inspections can result in serious accidents and lead in turn to the severe injuries associated with them.

- ▶ Carry out all daily inspections before and after work.
- ▶ Report any faults or damage to maintenance personnel immediately and instruct them to repair them.
- ▶ Only restart the carrier once the fault or damage has been repaired.

▲ WARNING Narcotics, alcohol and drugs

Narcotics, alcohol and medicinal drugs make their users less alert and affect their ability to concentrate. Negligence and incorrectly assessing a situation can result in serious injury or death.

- ▶ Never work on or with the hydraulic attachment when under the influence of narcotics, alcohol or drugs which affect your alertness.
- ▶ Never allow other people who are under the influence of narcotics, alcohol or drugs which affect their alertness to work on or with the hydraulic attachment.

2.15 Repair, precautions

Maintenance work must be conducted exclusively by authorized and trained maintenance personnel.

2.15.1 Maintenance works not allowed by the manufacturer

Some maintenance activities must be carried out exclusively by the manufacturer. If such maintenance activities are required, consult the authorized Customer center / Dealer in your area in order to ensure that they proceed safely.

The following maintenance activities are not allowed by the manufacturer:

- Repairs to the gear and hydraulic motor
- Replacing wear sleeves and pick boxes
- Welding work on the cutter drums
- Welding work on the gear housing

2.16 Changes to the hydraulic attachment, precautions

▲ **WARNING** Changes to the hydraulic attachment

Changes to the hydraulic attachment or the adapter plate may lead to serious injury.

- ▶ Never carry out any changes to the hydraulic attachment or the adapter plate.
- ▶ Only use original parts or accessories approved by the manufacturer.
- ▶ Modifications that entail new hazards may require a new procedure for assessing conformity.

▲ **WARNING** Injuries due to the use of incorrect spare parts

The use of incorrect or defective spare parts can result in risks to personnel as well as damage, malfunctioning or a total failure of the drum cutter.

- ▶ Only use original parts or accessories approved by the manufacturer.
- ▶ If there are any questions, consult the authorized Customer Center / Dealer in your area.

2.17 Environmental pollution, precautions

NOTICE Environmental pollution due to hydraulic oil

Hydraulic oil is permanently environmentally harmful. Escaped hydraulic oil will lead to groundwater and soil contamination. Organisms may die.

- ▶ Collect any hydraulic oil which escapes to avoid environmental pollution. For minor volumes use an absorbing medium (in case of an emergency use soil). In case of major leakages contain the hydraulic oil. It must not drain off and penetrate the ground or enter the water table or water supplies.
- ▶ Collect contaminated absorbing medium or soil in a watertight box/container and close it tight.
- ▶ Contact an authorized waste management company.
- ▶ Dispose of all contaminated material in accordance with the applicable environmental regulations.

3 Overview

3.1 Equipment description

The illustration gives an overview of the main parts and components of the hydraulic attachment. Actual details may differ.

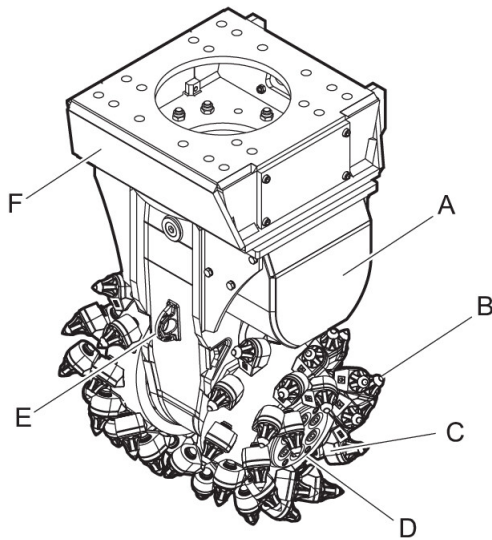

- A. Gear housing
- B. Round attack pick
- C. Pick box
- D. Cutter drum
- E. Transport lug
- F. Intermediate bracket

3.2 Function

The operation of a drum cutter is described in a simplified version below:

The drum cutter is an attachment for hydraulic carriers. The cutter drums are powered by the hydraulic motor and the gear of the drum cutter. The round attack picks are attached to the cutter drums at a defined angle. A rotating motion of the cutter drums facilitates the cutting process and thus reduces the size of the rock.

3.3 Modules

Cutter drums

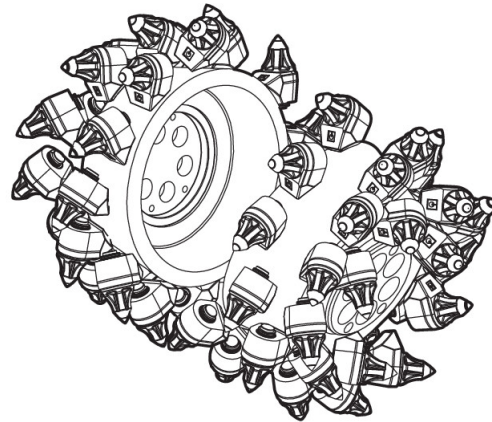

The transverse drum cutter is equipped with one left and one right cutter drum. These cutter drums are fastened by means of screws and special clamping sleeves directly to the drive shafts. A certain number of pick boxes are attached to the surface of the cutter drums. These hold the round attack picks in position.

The cutter drums can be designed with charging spirals (see arrow).

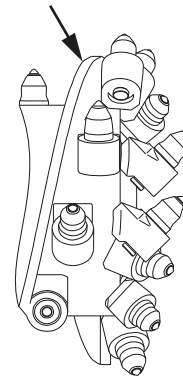

Transport lug

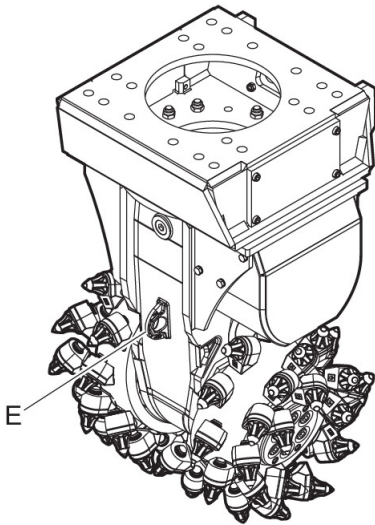

The transport lug (E) serves as an anchor point for the lifting gear when transporting the drum cutter.

Rotatable upper part

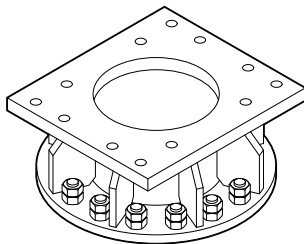

The drum cutter is fastened to a suitable adapter plate on the carrier boom via the rotatable upper part. The rotatable upper part is bolted to the adapter plate. Additionally, the cutter drum can be rotated via the rotatable upper part relative to the axis of the boom.

Gear housing

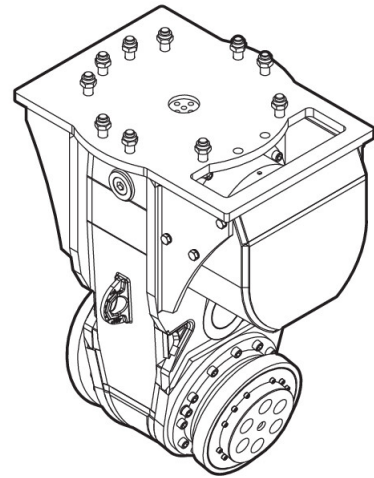

The gear housing contains a spur gear driven by a hydraulic motor. The gear's drive shafts turn the cutter drums. The hydraulic motor transfers the drive moment through the gear to the cutter drums.

Intermediate bracket

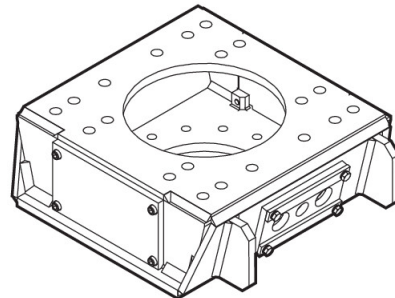

The intermediate bracket has been specially designed for trench work. It protects the hoses in the trench from damage.

Round attack picks

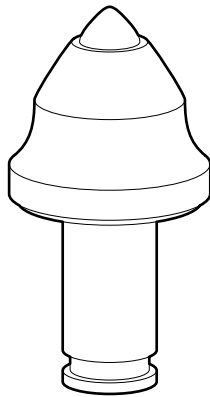

The round attack picks are made of steel and have a brazed tungsten carbide tip. The round attack picks are held in the pick boxes.

The appearance of the round attack picks may deviate from the image shown here.

Pick boxes

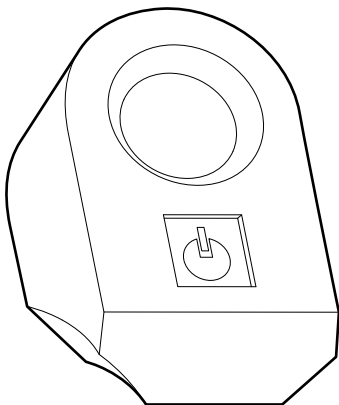

The pick boxes are welded onto the cutter drums for holding round attack picks. Some pick boxes may have a wear sleeve, which can be exchanged.

3.4 Signs / labels

▲ WARNING Missing warnings

The name plate and the labels on the hydraulic attachment contain important information about the hydraulic attachment and for personal safety. A missing warning can lead to overlooking or misinterpretation of possible risks and cause personal hazards. The signs and labels must always be clearly legible.

- ▶ Immediately replace any defective name plates and labels.
- ▶ Use the spare parts list to order new name plates and labels.

3.4.1 Signs



The warning symbol and the book symbol indicate that the Safety and Operating Instructions must be read prior to use of the hydraulic attachment and in particular the chapter on Safety.

3.4.2 Name plate

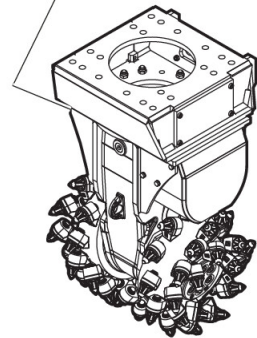
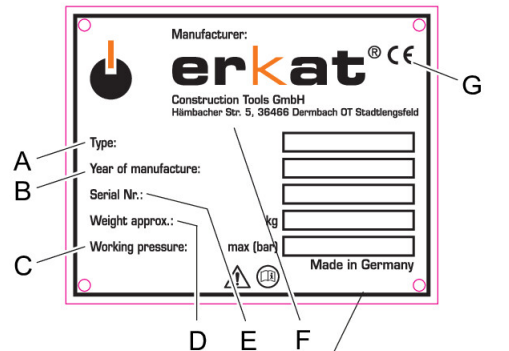

- A. Model
- B. Year of construction of hydraulic attachment
- C. Max. hydraulic pressure
- D. Weight of hydraulic attachment
- E. Serial number
- F. Name and address of manufacturer
- G. The warning symbol and the book symbol indicate that the Safety and Operating Instructions must be read prior to use of the hydraulic tool and in particular the chapter on Safety.
- H. The CE symbol indicates that the hydraulic attachment was produced in conformity with CE. You can find further information about this in the enclosed EC Declaration of Conformity.

3.4.3 Labels

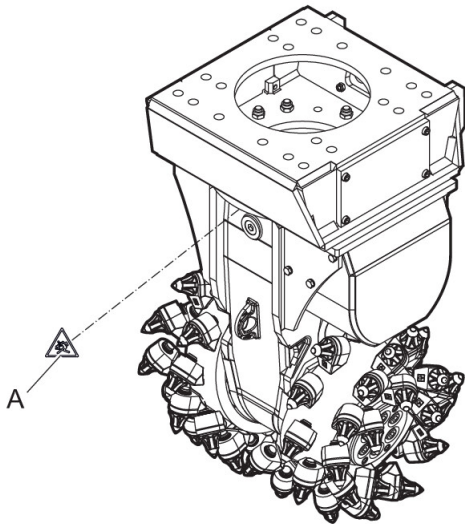

A. Danger zone

Danger zone



No persons should be within the danger zone. Fragments of material which come loose while operating the hydraulic attachment may be flung away and can cause serious injury if people are hit by them. Small objects falling from a great height can also cause serious damage.

3.5 Applications

The drum cutter is suitable for use in trenching and tunnelling, for demolition and renovation works, quarrying and in special underground engineering.

3.6 Working area and hazardous area

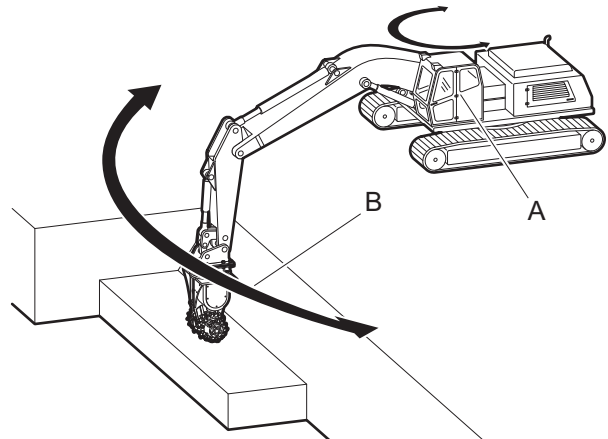

- A. Working area for operating personnel
- B. Hazardous area when working with the drum cutter
 - The working area for the operating personnel is in the cabin of the carrier.
 - The hazardous area is in the direct vicinity of the drum cutter.
 - Whilst operating the drum cutter, the minimum distance around the carrier is 15 m (50 ft).
 - When cutting reinforced concrete, the minimum distance around the carrier is 50 m (165 ft).

3.7 Removing the packaging

- Remove all the packaging material.
- Dispose of it in accordance with the applicable provisions.
- Check that the delivery is complete.
- Check the delivery for visual damage.
- If any defects are found, consult the authorized Customer Center / dealer in your area.

3.8 Scope of delivery

The drum cutter is delivered complete with:

- Drum cutter including rotatable upper part
- Safety and operating instructions
- Spare parts list
- EC Declaration of Conformity
- Hoses:
 - Pressure line
 - Tank line including precharge valve
 - Leakage oil line
 - Overpressure cover plate including O-ring and screws
 - Set of standard round attack picks including retainers (see table below)
 - Set of tools for round attack pick assembly and disassembly (see table below)

3.9 Standard round attack picks

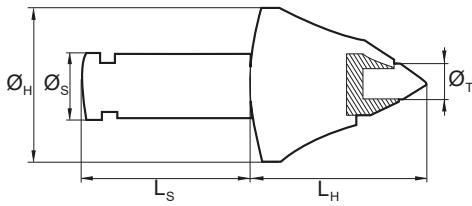

Type	\varnothing_S Shaft diameter	L_S Shaft length	\varnothing_H Head diameter	L_H Head length	\varnothing_T Tip diameter	Locking system
VC 1400	30.0 mm (1.18 in.)	80.0 mm (3.15 in.)	70.0 mm (2.76 in.)	75.0 mm (2.95 in.)	17.0 mm (0.67 in.)	Quick snap retainer
VC 2000	30.0 mm (1.18 in.)	80.0 mm (3.15 in.)	70.0 mm (2.76 in.)	75.0 mm (2.95 in.)	17.0 mm (0.67 in.)	Quick snap retainer
VC 3000	30.0 mm (1.18 in.)	80.0 mm (3.15 in.)	70.0 mm (2.76 in.)	75.0 mm (2.95 in.)	17.0 mm (0.67 in.)	Quick snap retainer

3.10 Tools for round attack picks

Set of tools for round attack pick

Type	A	B	C	D	E	F	G
VC 1400	x	x			x		
VC 2000	x	x			x		
VC 3000	x	x			x		

- A. Knock out tool
- B. Knock out tool for stuck picks (optional)
- C. Mounting tool for knock on retainer
- D. Dismantling tool for knock on retainer
- E. Dismantling tool for Quick snap retainer
- F. Puller for retainer sleeve picks
- G. Circlip pliers

4 Transport

▲ **WARNING** Hoist tipping over / hydraulic attachment falling

The hydraulic attachment is heavy. The hoist/lifting equipment and/or hydraulic attachment tipping over or falling may cause serious injury and material damage.

- ▶ Only transport the hydraulic attachment with lifting equipment with the right load-bearing capacity for the weight of the hydraulic attachment.
- ▶ Only lift and secure the hydraulic attachment with lifting gear (ropes, chains, shackles etc.) with the right load-bearing capacity for the weight to be lifted.
- ▶ Make sure that there is nobody near or under the suspended hydraulic attachment.

4.1 Transport using a crane

The drum cutter is equipped with transport lugs, for lifting by crane.

- Secure the hydraulic attachment with ropes or chains as shown in the following illustration.

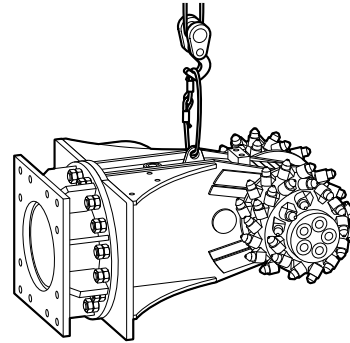

- Slowly lift the hydraulic attachment.
Ensure that the drum cutter hangs straight, if applicable observe any eccentric centre of gravity.
- Place the drum cutter on the assembly stand.

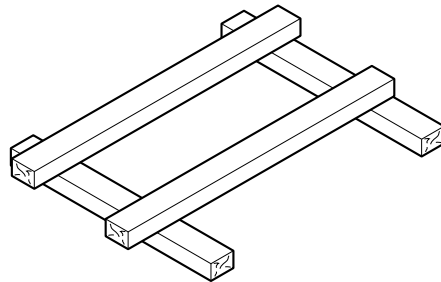

4.2 Transport using a forklift truck

Always transport the drum cutter whilst secured to the assembly stand.

▲ WARNING Hydraulic attachment tipping over

The hydraulic attachment tipping off the fork of the forklift truck or the pallet may cause serious injury.

- ▶ Place the hydraulic attachment on a pallet.
- ▶ Strap the hydraulic attachment to the pallet using suitable strapping, as shown in the illustration below.
- ▶ Move the fork of the forklift truck under the pallet so that the centre of gravity is between the prongs.

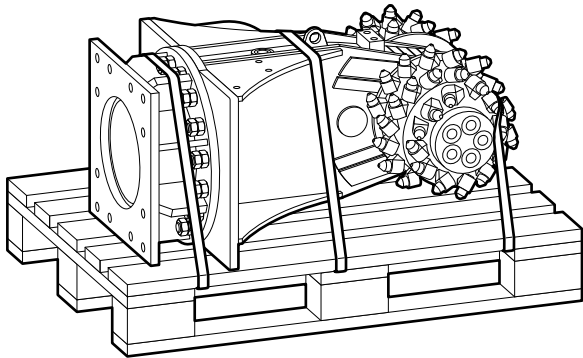

- Move the forks of the forklift truck under the assembly stand so that the hydraulic attachment cannot tip over.

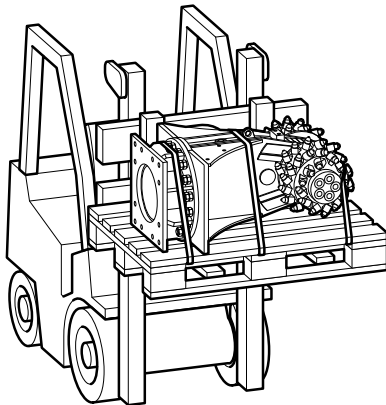

- Slowly lift the assembly stand with the hydraulic attachment.
- Transport the assembly stand with the hydraulic attachment to the location provided for.

4.3 Transport using a truck

Always transport the drum cutter whilst secured to the assembly stand.

▲ WARNING Hydraulic attachment tipping over / slipping

The hydraulic attachment slipping or tipping over and falling from the loading area of a lorry may cause serious injury.

- ▶ Place the hydraulic attachment on a pallet.
- ▶ Strap the hydraulic attachment to the pallet using suitable strapping (see illustration in chapter **Transport using a forklift truck**).
- ▶ Place the pallet with the hydraulic attachment on an anti-slip mat.
- ▶ Secure the hydraulic attachment to the loading area with ropes or chains; use any available transport lugs.
- Secure the hydraulic attachment on the assembly stand and the loading surface as shown in the following illustration.
- Observe all the applicable national/regional regulations on securing loads.

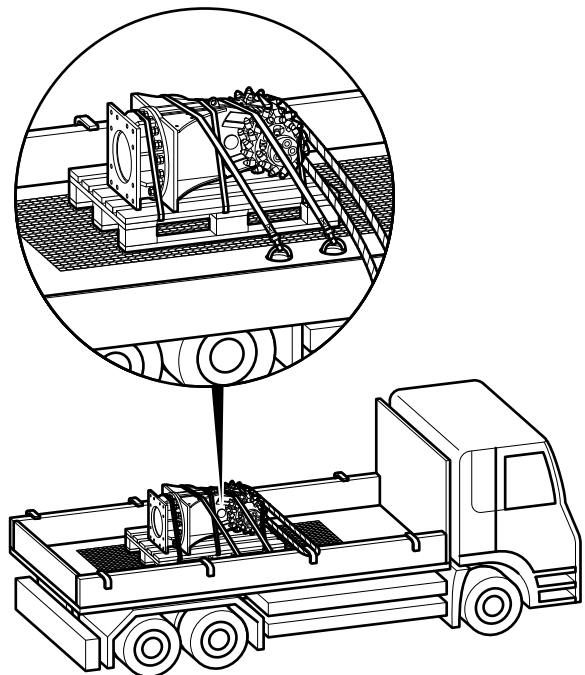

5 Installation

▲ WARNING Hot hydraulic oil squirting out

The hydraulic system is under high pressure. If hydraulic connections come loose or are disconnected, hydraulic oil will squirt out under high pressure. Hydraulic oil squirting out can lead to serious injury.

- ▶ Depressurise the hydraulic system before connecting or disconnecting the hydraulic circuits of the hydraulic attachment (see chapter **Depressurising the hydraulic system**).

▲ WARNING Risk of death due to defective first installation and commissioning

Faults during the first installation or commissioning can lead to life-threatening situations and may cause considerable damage to property.

- ▶ Have the first installation and commissioning exclusively conducted by authorised specialist personnel.
- ▶ Do not undertake unauthorised first installation and commissioning.

NOTICE Damage to the hydraulic attachment

Working with a hydraulic attachment mounted to a long reach boom may cause damage to the hydraulic attachment.

- ▶ Before working with a hydraulic attachment mounted to a long reach boom consult the authorized Customer Center / Dealer in your area.

5.1 Media/consumables

The following consumables are used when operating the hydraulic attachment:

5.1.1 Mineral hydraulic oil

All hydraulic oil brands prescribed by the carrier manufacturer are also suitable for use when operating the hydraulic attachment.

However, the oil should comply with viscosity class HLP 32 or higher.

In summer and in hot climates, oils of viscosity class HLP 68 or higher should be used.

In all other respects the regulations of the carrier manufacturer are to be taken into consideration.

Optimum viscosity range	= 30 - 60 cSt
Max. start viscosity	= 2000 cSt
Max. oil temperature	= 80 °C

Special conditions apply to using the hydraulic attachment at low temperatures (see chapter **Low ambient temperature**).

- Check the oil filter!

An oil filter must be integrated in the tank line of the hydraulic system. The maximum mesh width allowed for the oil filter is 50 microns; it must have a magnetic separator.

5.1.2 Non-mineral hydraulic oil

NOTICE Mixed hydraulic oil

Never mix mineral and non-mineral hydraulic oils! Even small traces of mineral oil mixed in with non-mineral oil can result in damage to both the hydraulic attachment and the carrier. Non-mineral oil loses its biodegradability.

- ▶ Only use one type of hydraulic oil.

If you are using non-mineral oil it is imperative that the name of the oil in use be indicated when returning the hydraulic attachment for repair.

In order to protect the environment or on technical grounds, hydraulic oils are currently being used which are not classified as HLP mineral oils.

Before using hydraulic oils of this kind it is imperative to ask the carrier manufacturer whether operations with such fluids are possible.

Our hydraulic attachments are basically designed for use with mineral oils. Consult the authorized Customer Center / Dealer in your area before using other hydraulic oils approved by the carrier manufacturer. Following initial assembly and after any workshop repairs, our hydraulic attachments are subjected to a test run on a test bed powered by **mineral oil**.

5.1.3 Gear oil

Temperature range	Media /consumables	Manufacturer
-20 to +30 °C -4 to 86 °F	GPD 80 Spartan EP 100	ESSO
-15 to +40 °C 5 to 104 °F	Spartan EP 220 Getriebeöl GPD 90	
-20 to +30 °C -4 to 86 °F	Mobil Gear 80 EP Mobilube GX 80	MOBIL
-15 to +40 °C 5 to 104 °F	Mobilube GX 90 Mobil Gear 630	
-20 to +30 °C -4 to 86 °F	Shell Spirax 80 EP Shell Omala oil 100	SHELL
-15 to +40 °C 5 to 104 °F	Shell Omala oil 220 Shell Spirax 90 EP	
-20 to +30 °C -4 to 86 °F	EP SAE 80 Energol GR XP 68	BP
-15 to +40 °C 5 to 104 °F	EP SAE 90 Energol GR XP 220	
-20 to +30 °C -4 to 86 °F	Texaco Meropa 68 Universal Gear Lubricant EP 80	TEXACO
-15 to +40 °C 5 to 104 °F	Texaco Meropa 220 Universal Gear Lubricant EP 90	
-20 to +30 °C -4 to 86 °F	EP 80 Degol BG 68	ARAL
-15 to +40 °C 5 to 104 °F	EP 90 Degol BG 220	

5.2 Preconditions for the carrier

The carrier must fulfil the following criteria in order that a drum cutter can be attached to it:

- A complete hydraulic hammer or shearer line right to the end of the carrier boom must be available.
- The motor's pressure line is set to max. 350 bar (5076 psi).
- The pressure of the tank line is at least 5 bar (73 psi) above the pressure of the hydraulic motor's case drain line.
- The pressure in the leakage oil line is of 3 bar (44 psi) maximum during operation.
- The cabin of the carrier must be protected by means of suitable measures (e.g. armoured glass) against damage due to flying rock.
- The cabin of the carrier must allow an adequate view of the working area.
- Lighting with a minimum strength of 150 Lux must be attached to the carrier and this must be protected against damage.
- An EMERGENCY STOP device must be available at every operating and driving position and this must always be functional.
- An acoustic warning signal with manual activation must be available on the carrier and this must always be functional.
- All actuation elements present at the operating and driving position must be equipped with a dead man's switch.
- All purchased parts must comply with the specifications of the carrier manufacturer.

5.3 Preconditions for adapter plate

The drum cutter is supplied with a rotatable upper part. This rotatable upper part has a standardised hole pattern so that it can be mounted to an adapter plate.

The mating areas of adapter plate must be ground plane (surface roughness Ra 12.5 / max. planeness deviation 0.5 mm (0.02 in.))

Note: The adapter plate is not included in the scope of delivery of the drum cutter.

5.4 Attaching the hydraulic attachment to the carrier

5.4.1 Mechanical mounting aspects

You need an assistant to attach the hydraulic attachment to the carrier.

- Agree on hand signals with your assistant, to enable him to help you placing the carrier in the proper position to attach the hydraulic attachment.

▲ **WARNING Injury by impacts**

A sudden movement of the carrier may cause your assistant to be hit and injured by the boom or the hydraulic attachment.

- ▶ Only move the boom very slowly and in a controlled manner while an assistant is within the danger zone.
- ▶ Always keep sight of your assistant.

▲ **WARNING Hands and fingers being cut off or hurt**

Bores and surfaces can act like a pair of scissors and cut off or hurt parts of your body.

- ▶ Never use your fingers to check bores or fitting surfaces.

NOTICE The adapter plate can come loose

The adapter plate can come loose if the fastening screws are not designed for local high loads.

- ▶ Only use the Allen screws of strength category 8.8 and the pairs of lock washers included in the delivery to attach the adapter plate or the base plate.
- Place the drum cutter on the assembly stand within the range of the carrier.
- Apply Anti-Seize to the Allen screw threads (A) before inserting them.

The contact faces of the screw head and the lock washers (B) must not be lubricated.

- Align the adapter plate (C) with the drum cutter as shown.

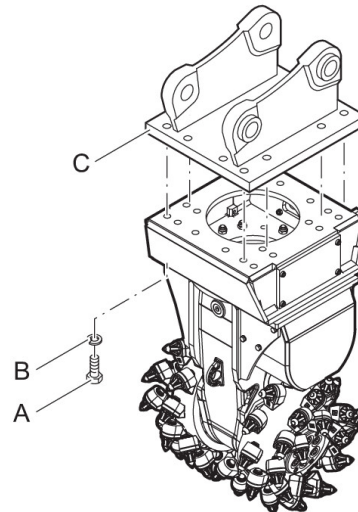

- Fit a pair of lock washers (B) onto every screw.
- Tighten the Allen screws (A) with an Allen key.
- Tighten the Allen screws (A) with the required tightening torque.

Type	Key size	Tightening torque
VC 1400	22 mm (0.89 in.)	1500 Nm (1106 ft lbs)
VC 2000		
VC 3000		

- Lower the stick of the carrier into the holder provided on the adapter plate.
- Let your assistant instruct you until the bores in the adapter plate (C) and in the stick (D) are properly aligned.
- Install the stick bolt (E) and lock it.

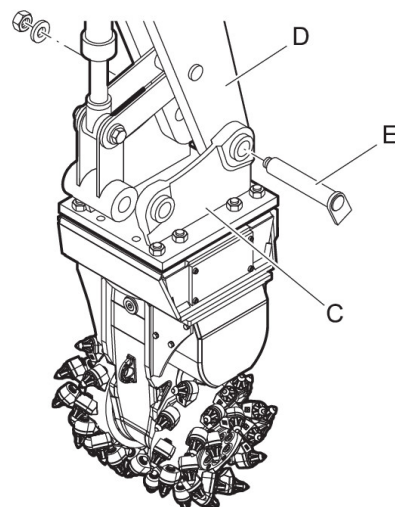

- Lift the hydraulic attachment.

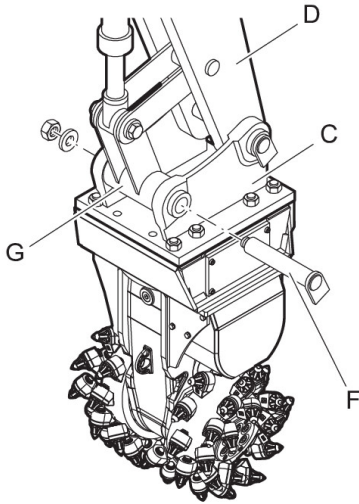

- Extend the bucket cylinder until the bore in the linkage (G) links up with the bore in the adapter plate (C).
- Install the linkage bolt (F) and lock it.
- Carefully move the bucket cylinder into both end positions.

The adapter plate must not be stopped by mechanical stops in either position. Consult the authorized Customer Center / Dealer in your area if the adapter plate is stopped by a mechanical stop.

5.4.2 First installation

▲ WARNING Risk of death due to defective first installation

Faults during the first installation or commissioning can lead to life-threatening situations and may cause considerable damage to property.

- ▶ Have the first installation exclusively conducted by authorised specialist personnel.
- ▶ Do not undertake unauthorised first installation.

▲ WARNING Unexpected movement

Sudden movements of the carrier may cause serious injury.

- ▶ Secure the carrier such that it cannot move unexpectedly.
- ▶ Observe the carrier manufacturer's instructions.

NOTICE Damage due to incorrect oil pressure setting
Incorrect oil pressure setting can result in severe damage to property and the environment.

- ▶ Before installing the hydraulic attachment to the carrier check the oil pressure setting of pressure line with a hydraulic flow tester.
- ▶ Check the tank line pressure with an additional manometer mounted between hydraulic flow tester and tank line.
- ▶ Ensure the technical specifications are fulfilled (see chapter **Technical specifications**).

Filling hydraulic motor

Note: Prior to first commissioning the hydraulic motor of the drum cutter must be filled with hydraulic oil (see chapter **Technical specifications**).

Install separate leakage oil line

The separate leakage oil line including separate leakage oil filter must be installed from the shut-off valve on the boom to the carrier's hydraulic oil tank. The operator must pre-install a suitable connection on the carrier's hydraulic oil tank for the leakage oil line.

NOTICE Damage due to incorrect installed hydraulic hoses

Incorrectly installed hydraulic hoses can result in severe damage to property and the environment. The maximum pressure of the leakage oil line is 3 bar.

- ▶ Install hydraulic hoses such that they always possess sufficient play for turning and rotating motions of the boom.
- ▶ Always check the leakage oil line pressure when mounting the drum cutter to a carrier.
- Install a separate leakage oil line along the hydraulic hoses on the boom and secure with cable ties.
- Install the separate leakage oil line (J) with leakage oil filter (I) to the connection on the carrier's hydraulic oil tank (K).

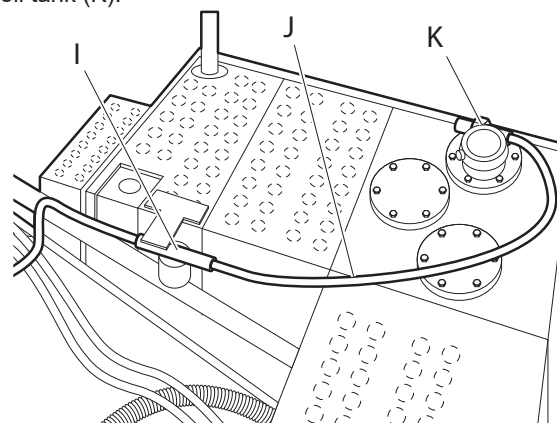

Follow the safety and operating instructions of the carrier when connecting the leakage oil line to the hydraulic oil tank.

- Attach the leakage oil line to the pre-installed connection on the hydraulic oil tank and tighten with the required tightening torque.
- Install the leakage oil filter at an appropriate location on the carrier.

5.4.3 Making the hydraulic connections

NOTICE Faulty hydraulic installation

The carrier must have a suitable hydraulic installation to operate the hydraulic attachment. Improperly installed lines and incorrectly rated sizes may cause the oil to heat up and the hydraulic attachment to be damaged.

- ▶ Only use hydraulic lines of the rated sizes as instructed (see chapter **Technical Specifications**).
- ▶ Check the rated size of the hydraulic lines on existing hydraulic installations! All supply and return lines for the hydraulic oil must have a sufficient inside diameter and wall thickness.
- ▶ Route all hydraulic hoses in a torsion-free manner.
- Switch off the carrier.
- Depressurise the hydraulic system according to the manufacturer's safety and operating instructions for the carrier.
- Close all shut-off valves in the installation at the boom, if no quick couplings are used.

NOTICE Damage to hydraulic parts

Polluted hydraulic lines and connections may enable sand, fragments of material and dirt to penetrate the hydraulic attachment and damage the hydraulic parts.

- ▶ Clean the hydraulic lines and connections prior to connecting the hydraulic lines.
- Have dirty hydraulic lines rinsed through by a specialist company.
- Clean dirty hydraulic line connections with a suitable grease-dissolving universal cleaner.
- Observe the cleaner manufacturer's information on safety and use.

NOTICE Property damage due to unauthorised removal of the check valve

Removing the check valve from the tank line of hydraulic hammer systems leads to destruction of the hydraulic motor of the drum cutter.

- ▶ Never remove the check valve from the tank line of hydraulic hammer systems.

The drum cutter is supplied with 3 hydraulic hoses, already installed by the manufacturer:

- Pressure line to the drum cutter
- Tank line with check valve to the carrier
- Leakage oil line to the carrier

Note: Installation of a hydraulic circuit suitable for operating a drum cutter on the carrier is the responsibility of the operator. The actions and safety requirements pertinent to this can be found in the carrier's operating manual.

For operation of the drum cutter, required adjustments (pressure and hydraulic flow) on the carrier are the responsibility of the operator.

- Consult, for installation to a carrier with hydraulic hammer system, installation plan 1 (see chapter **Hydraulic installation version 1 for hydraulic hammer**).
- Consult, for installation to a carrier with hydraulic shear system, installation plan 2 (see chapter **Hydraulic installation version 2 for hydraulic shear systems**).

Note: If it is necessary to remove the check valve, e.g. when connecting to a hydraulic shear system for backwards and forwards rotation, it is necessary to guarantee that the pressure in the tank line is at least 5 bar (73 psi) higher than that in the leakage oil line at all times. This pressure differential must be measured, documented and communicated to the manufacturer to prevent the warranty on the hydraulic motor becoming null and void. Contact the authorized Customer Center / Dealer in your area before removing the check valve.

- Clean the area around the shut-off valve on the left side of the boom.
- Remove the end cap from the shut-off valve on the boom and save for future use.
- Unscrew the end cap from the pressure line and save for future use.
- Connect the pressure line to the shut-off valve fitting of the supply line on the left side of the boom.
- Clean the area around the shut-off valve on the right side of the boom.

- Remove the end cap from the shut-off valve of the boom and save for future use.
- Unscrew the end cap for the tank line and save for future use.
- Connect the tank line to the shut-off valve fitting of the return line on the right side of the boom.

Note: To transport leakage oil from the hydraulic motor of the drum cutter, use the separate leakage oil line of the carrier. If a separate leakage oil line is not available, it is necessary to install one (see chapter **First installation / Install separate leakage oil line**). Installation of a leakage oil line to drain oil to tank is the responsibility of the operator.

NOTICE Environmental damage due to hydraulic oil

Hydraulic oil is environmentally harmful and must not penetrate the ground or enter the water table or water supplies.

- ▶ Collect any hydraulic oil which escapes.
- ▶ Dispose of it in accordance with the applicable environmental regulations.

- Position an oil receiver tank beneath the leakage oil line of the drum cutter.
- Use a funnel to fill up the leakage oil line with hydraulic oil until it overflows.
- Connect the leakage oil hose from the drum cutter onto the separate leakage oil line of the carrier's boom.

5.5 Removing the hydraulic attachment from the carrier

- You need an assistant to remove the hydraulic attachment.
- Agree on hand signals with your assistant, to enable him to help you move the boom.

▲ **WARNING Injury by impacts**

A sudden movement of the carrier may cause your assistant to be hit and injured by the boom or the hydraulic attachment.

- ▶ Only move the boom very slowly and in a controlled manner while an assistant is within the danger zone.
- ▶ Always keep sight of your assistant.
- Put out the assembly stand within reach of the boom.

▲ **WARNING Unexpected movement**

Sudden movements of the carrier may cause serious injury.

- ▶ Secure the carrier such that it cannot move unexpectedly.
- ▶ Observe the carrier manufacturer's instructions.

▲ **WARNING Hydraulic hose flailing about**

Pressurised hydraulic hoses will flail about when bolted connections have come loose or have been loosened. A hydraulic hose flailing about may cause serious injuries.

- ▶ Depressurise the hydraulic system before disconnecting a hydraulic hose (see chapter **Depressurising the hydraulic system**).

▲ **WARNING Hot parts**

The cutter drums, hoses, pipes and fittings become very hot during operation. Touching them may lead to burns.

- ▶ Never touch hot parts.
- ▶ If you have to carry out activities where you have to touch the parts, wait for them to cool down first.

- Position the drum cutter carefully on the assembly stand.
- Close all shut-off valves in the installation at the boom if no quick couplings are used.
- Disconnect the hose lines to and from the hydraulic attachment at the boom side.
- Close off all open hose ends.

▲ **WARNING Metal chips shooting off**

When hammering out bolts, chips may shoot off and cause serious eye injuries.

- ▶ Wear safety glasses when hammering out the bolts.

- Remove the bolt locks from the stick and linkage bolts.
- Drive out the linkage bolt with a steel arbor and a hammer.
- Switch on the carrier.
- Retract the bucket cylinder.
- Drive out the stick bolt with a steel arbor and a hammer.
- Move the carrier stick out of the adapter plate.
- Secure the drum cutter on the assembly stand.
- Remove the fastening screws of the adapter plate.

- Lift the adapter plate with a suitable lifting equipment and put it down on timber support blocks.
- Save the fastening screws and the pairs of lock washers for future use.

6 Operation

▲ **DANGER Risk of death due to a failure to adhere to the safety clearance**

A failure to adhere to the safety clearance during cutting operations can result in severe injuries and even death.

- ▶ Ensure that no persons are within a distance of 15 m (50 ft) during cutting work .
- ▶ Ensure that no persons are within a distance of 50 m (165 ft) during cutting work on reinforced steel.
- ▶ Immediately shut down the carrier with the drum cutter, if a person accesses the hazardous area during cutting work.
- ▶ Only switch on the carrier with the drum cutter once certain that no persons are located in the hazardous area.

▲ **WARNING Risk of explosion**

If the hydraulic attachment is equipped with HATCON explosion may occur when the contained lithium batteries are penetrated by pieces of steel or reinforcing bars.

- ▶ Avoid impact of reinforcement, flying rocks or even explosives on HATCON.
- ▶ Check the HATCON before operating.

▲ **WARNING Hot hydraulic oil squirting out**

The hydraulic system is under high pressure. If hydraulic connections come loose, hydraulic oil will squirt out under high pressure. Hydraulic oil squirting out can lead to serious injury.

- ▶ Immediately switch off the hydraulic attachment and the carrier if you detect any leaks in the hydraulic circuits.
- ▶ Depressurise the hydraulic system (see chapter **Depressurising the hydraulic system**).
- ▶ Repair any leaks before operating the hydraulic attachment again.

▲ **WARNING Injuries due to moving parts**

The rotating cutter drums can cause severe injuries.

- ▶ When operating the drum cutter always maintain a safety distance of at least 15 m (50 ft).
- ▶ During operation do not reach into moving parts or handle moving parts.
- ▶ Observe run-on time: Before touching the drum cutter ensure that no parts are still moving.
- ▶ When in the hazardous area wear closely fitting clothes with a minimal tear strength.

▲ **WARNING Hot parts**

The cutter drums, hoses, pipes and fittings become very hot during operation. Touching them may lead to burns.

- ▶ Never touch hot parts.
- ▶ If you have to carry out activities where you have to touch the parts, wait for them to cool down first.

▲ **WARNING Lung disease**

When cutting with the drum cutter, dust harmful to health is generated. Inhaled dust can result in long-term lung damage or have other effects on health.

- ▶ When working in close proximity to the cutting work always wear light respiratory protection.
- ▶ Always keep the doors to the carrier closed.

▲ **WARNING Injuries due to severe vibrations**

Strong vibrations can result in the long-term in significant injuries and chronic damage to health.

- ▶ Drive the carrier with an even load whenever possible, in order to minimise vibrations produced.
- ▶ Avoid abrupt starting up or stopping of the cutter drums.

NOTICE Hydraulic oil too hot

The temperature of the hydraulic oil must not exceed 80 °C (176 °F). Exceeding the hydraulic oil temperature of 80 °C (176 °F) leads to hydraulic motor failure.

- ▶ The temperature of the hydraulic oil must be monitored, especially in continuous operation.
- ▶ Shut off the carrier and the hydraulic attachment if you measure an increased temperature in the tank.
- ▶ Check the hydraulic installation and the pressure relief valve.

NOTICE Environmental damage due to hydraulic oil

Hydraulic oil is environmentally harmful and must not penetrate the ground or enter the water table or water supplies.

- ▶ Collect any hydraulic oil which escapes.
- ▶ Dispose of it in accordance with the applicable environmental regulations.

6.1 Preparations before starting

▲ DANGER Fragments flying around

Fragments of material which come loose while operating the hydraulic attachment may be flung away and can cause serious injury if people are hit by them. Small objects falling from a great height can also cause serious damage.

During hydraulic attachment operation the danger zone is considerably greater than during the excavation operation due to fragments of stone and pieces of steel flying around, and for this reason the danger zone must, depending on the type of material to be worked on, be enlarged correspondingly, or secured in a suitable manner through corresponding measures.

- ▶ Secure the danger zone.
- ▶ Ensure that no persons are within a distance of 15 m (50 ft) during cutting work.
- ▶ Ensure that no persons are within a distance of 50 m (165 ft) during cutting work on reinforced steel.
- ▶ Stop the hydraulic attachment immediately if anyone enters the danger zone.
- ▶ Close the windscreen and the side windows of the driver's cab.
- ▶ The cabin of the hydraulic carrier must be protected by means of suitable measures (e.g. armoured glass, min. class P4A according to DIN EN 356) against damage due to flying rock.
- ▶ Make sure no flying fragments can leave the danger zone (e.g. safety fence).

▲ WARNING Falling carrier

A carrier falling or tipping over due to the surface not being level may cause serious injury and material damage.

- ▶ Always observe great care when moving the carrier.
- ▶ Do not use the hydraulic attachment until the carrier is positioned stably.

NOTICE Damage due to a failure to observe the operating conditions

A failure to observe the compressive strengths of the cutting material can lead to severe damage to property.

- ▶ Prior to every cutting process check the compressive strength of the cutting material.
- ▶ Never exceed the max. compressive strength of the cutting material permissible during cutting work (see chapter **Technical specifications**).

Depending on the material being cut, round attack picks will wear at different rates. A particularly high wear rate should be expected working in the following materials:

- reinforced concrete

- rock with a high SiO₂ content, when using spray water and when cutting under water
- hard rock such as granite, basalt

Note: Prior to using the drum cutter in the aforementioned materials, contact the authorized Customer Center / Dealer in your area in order to guarantee optimum working efficiency. The authorized Customer Center / Dealer will advise on the use of suitable tools and the requisite cutting capacity.

- Before using the drum cutter always carry out all maintenance actions mandatory before and after operating (see chapter **Maintenance schedule**).
This is to prolong service life and maintain high and save productivity.
- Make sure that there are no people in the danger zone.
- Start the carrier as instructed by the carrier manufacturer.
- Raise the drum cutter.
- Let the carrier heat up until the operating temperature prescribed by the carrier manufacturer has been reached.
- Put the carrier in working position.

6.1.1 Ambient temperature

Note: The drum cutter is designed for ambient temperatures of -25 °C to 50 °C (-13 °F to 122 °F), contact the authorized Customer Center / Dealer in your area when working at other ambient temperatures is required.

6.2 Commissioning

Note: Observe the carrier's safety and operating instructions for the following essential actions.

- Check all fastenings, hoses and couplings.
- Check the hydraulic oil level and shut-off valves.
- Check all hydraulic connections for leaks and tightness.

NOTICE Damage due to incorrect commissioning

Idle running during the first use of the hydraulic motor can result in damage to the motor.

▶ Load the motor when first starting up.

- Switch motor on.
- Bring the motor slowly up to the normal operating conditions (oil volume, oil pressure).

6.2.1 Checks during commissioning

- Check the following points when first operating the drum cutter:
 - leak-tightness of all hydraulic connections
 - feed pressure for both directions of rotation
 - pressure in leakage oil line, maximum 3 bar in continuous operation
 - oil temperature, target value 50 °C to 80 °C (122 °F to 176 °F)

6.3 Switching the drum cutter on and off

After properly attaching the hydraulic attachment to the carrier, the hydraulic attachment can be operated using the carrier's hydraulic system. All functions for normal carrier operation remain intact.

The hydraulic attachment is switched on and off using electrical and hydraulic signals.

If you have any questions about electric / hydraulic commands, consult the carrier manufacturer and/or the authorized Customer Center / Dealer in your area.

NOTICE Damage due to switching on and off the drum cutter when in contact with material

Switching on and off the drum cutter in a lowered position when in contact with material can result in serious damage to property and strong vibrations.

- ▶ Only switch on or off the drum cutter in a raised position without contact with material.
- ▶ Never switch on or off the drum cutter when working at full capacity.
- ▶ Never switch off the drum cutter from full idling speed.
- Switch the hydraulic attachment on and off, as described in the carrier's operating instructions.
- When leaving the driver's cab, set the safety switch/lever for the electrical / hydraulic attachment installation to the "OFF" position.

Carry out the above actions to prevent any unintended start-up of the hydraulic attachment.

6.4 Functional test

Always carry out a functional test before putting the drum cutter into use. Check that all hydraulic lines and connections are tight and that the drum cutter works without any problem.

- Prepare the drum cutter so that you can start using it (see chapter **Preparations before starting**).
- Bring the drum cutter into a raised position.
- Switch on the drum cutter and start up.
- Slowly lower the rotating cutter drums onto the cutting material.
- Slowly apply the cutter drums and ensure that the cutter drums are not blocked.
- Observe the hydraulic lines and whether the drum cutter works properly.
- Immediately lift the drum cutter and switch off if oil leaks from the hydraulic lines or other malfunctions occur.
- Depressurise the hydraulic system (see chapter **Depressurising the hydraulic system**).
- Only take the drum cutter back into operation once all leaks or malfunctions have been remedied.

6.5 Correct operation

- Bring the drum cutter into a raised position.
- Switch on the drum cutter and start up.
- Slowly lower the rotating cutter drums onto the cutting material.
- Slowly apply slight pressure to the cutter drums and ensure they do not block.

▲ **WARNING Risk of injury due to loss of stability**

Lateral cutting movements can endanger the stability of the carrier and result in strong vibration being exerted on the machine and the operator, which can in turn lead to severe injuries and considerable damage to property.

- ▶ Do not expose the carrier to the effects of strong forces.
 - ▶ Ensure that the carrier maintains constant contact with the ground during cutting work.
 - ▶ Always execute cutting movements slowly.
 - ▶ Never switch the drum cutter on or off when in contact with the cutting material.
- Execute cutting movements towards the carrier vehicle or in both directions.

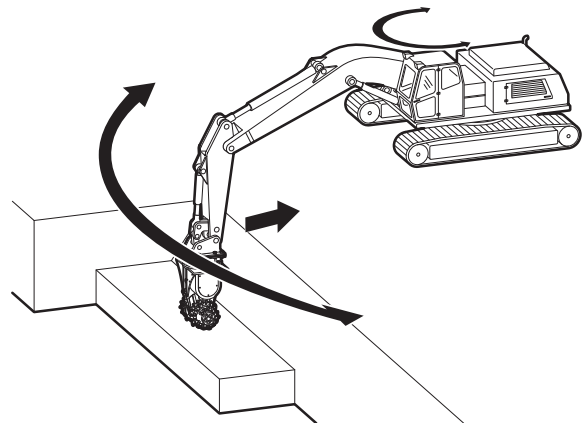

- Execute the cutting movements either in a horizontal or vertical direction. With lateral cutting movements, always ensure that no strong forces are exerted on the carrier.
- Always introduce the rotating cutter drums to the cutting material slowly in order to avoid stalling.
- Always apply slight pressure to the drum cutter when cutting. Always ensure that the cutter drums do not come to a standstill.
- With lateral cutting movements with the boom, always ensure that no strong forces are applied to the carrier.

- Never switch the drum cutter on or off when in contact with the cutting material.
- Check the hydraulic oil temperature regularly when working in continuous operation. This must not exceed 80 °C (176 °F).

When cutting abrasive materials (e.g. concrete, sandstone) and using water spray for dust suppression, it is necessary to reckon with considerably greater wear rates. The same applies when cutting under water.

6.6 Prohibited operation

- Do not activate the drum cutter with the carrier in driving operation.

6.6.1 Cylinder end positions

- Reposition the carrier to avoid working with the cylinder in its end positions.

Avoid operating the hydraulic attachment when the carrier stick and bucket cylinder are in one of their end positions. These end positions have damping facilities; the hydraulic cylinder may be damaged by prolonged use while in its end positions.

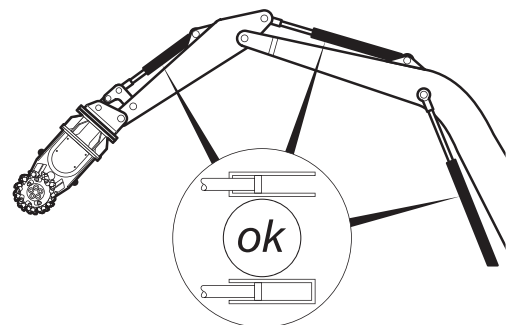
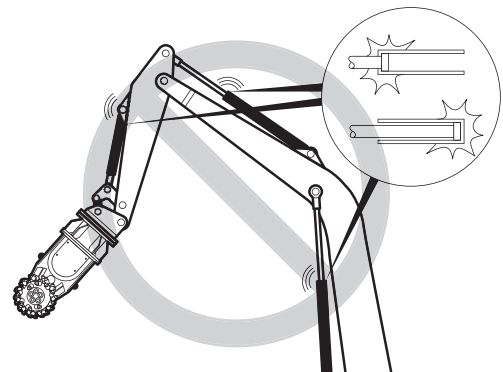

6.6.2 Moving the carrier

- Never relocate the carrier sideways by placing the hydraulic attachment on the ground to lift the carrier. This would seriously damage the hydraulic attachment.

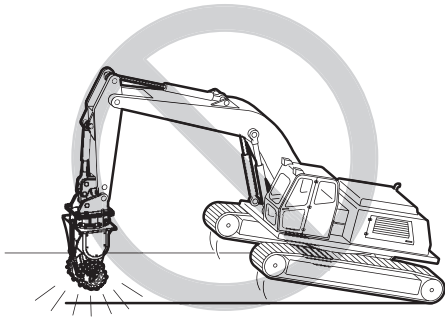

6.6.4 Impacting/chopping

- Do not use the hydraulic attachment to impact or chop to destroy material. This would seriously damage the hydraulic attachment.

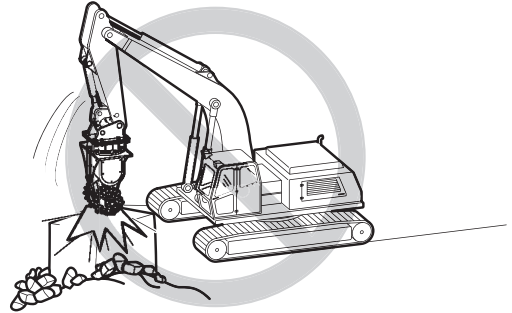

6.6.3 Lifting/Transporting

- Never use the hydraulic attachment to lift or transport loads. The hydraulic attachment was not constructed to lift or transport loads. This would damage the hydraulic attachment.

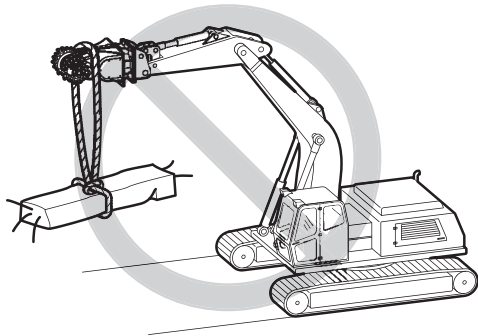

6.7 Activities after use

- After use carry out all activities specified in the maintenance schedule to perform after every shift.

6.8 Turning the drum cutter

When carrying out certain works (e.g. tunnel boring) with the drum cutter, it may be necessary to mount it at an angle on the carrier.

The following chapter explains how the drum cutter can be turned in order to facilitate angular cutting.

▲ **WARNING** Injury due to inadequate securing of the carrier

Inadequate securing when working on the drum cutter can lead to severe injuries.

- ▶ When working on the drum cutter shut down the complete system and secure against being switched on again.
- ▶ Ensure there is no person below the lifted drum cutter.
- Ensure that the drum cutter is connected properly to the carrier (see chapter **Attaching the hydraulic attachment to the carrier**).
- Position the drum cutter carefully on the ground in a vertical position.
- Remove the counter nuts, nuts and bolts between rotatable upper part and gear housing.

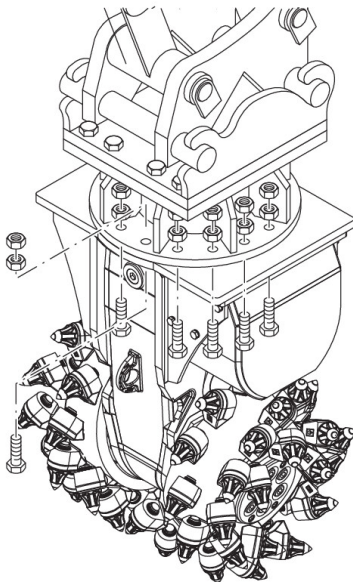

- Slowly lift the boom until the drum cutter is suspended slightly above ground.

The drum cutter is suspended securely on the centre bolt (A).

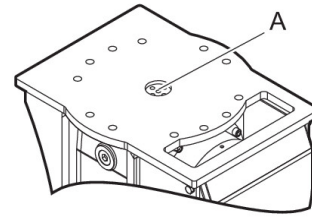

- Turn the drum cutter to the desired position.

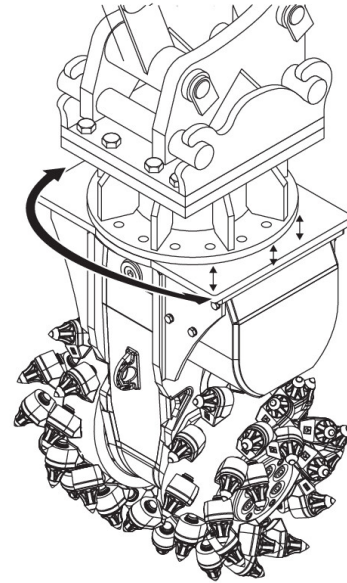

▲ **WARNING** Hands and fingers being cut off or hurt

Bores and surfaces can act like a pair of scissors and cut off or hurt parts of your body.

- ▶ Never use your fingers to check bores or fitting surfaces.
- Fix the drum cutter in the required position with the bolts and nuts.
- Slowly lower the drum cutter onto the ground.
- Tighten all bolts and nuts connecting the rotatable upper part to the gear housing with the required tightening torque (see chapter **Bolt connections / Tightening torques**).
- Fit counter nuts to each bolt.

Note: Working with rotated drum cutter causes higher forces to be fed to the carrier. Also the wear of the individual components of the drum cutter increase.

7 Maintenance

The maintenance work described in the following sections is necessary for the optimum and fault-free operation of the hydraulic attachment.

Insofar as regular checks reveal a rapid rate of wear, it may be necessary to increase the frequency of maintenance in line with the actual rate of wear.

In the event of questions regarding maintenance work and intervals, consult the authorized Customer Center / Dealer in your area.

The following maintenance activities are mainly carried out by the carrier driver. Maintenance activities that should be carried out in a workshop are indicated as such.

▲ DANGER Risk of death due to a failure to observe the maintenance intervals

Delaying or omitting maintenance in contravention of the fixed maintenance intervals can result in serious accidents and damage to property.

- ▶ Ensure that all fixed maintenance works and intervals are adhered to by authorized maintenance personnel.
- ▶ Always monitor the wear of the individual components and replace worn parts.
- ▶ Only carry out maintenance activities allowed by the manufacturer.
- ▶ Contact the manufacturer regarding maintenance work not allowed by the manufacturer.

▲ WARNING Risk of injury due to inadequate safeguards whilst working on the machine

Inadequate safeguarding of the carrier during maintenance or service work can lead to serious injuries.

- ▶ Only perform work on the machine when at a standstill.
- ▶ Depressurise the hydraulic system (see chapter **Depressurising the hydraulic system**).
- ▶ Prior to restarting, install all covers, tighten threaded and safety devices in accordance with specifications and check that they work.

▲ WARNING Danger of injury due to moving parts

Rotating components and/or components with linear movement can cause serious injury.

- ▶ Prior to all maintenance work on moving parts, switch off the machine and safeguard it against being switched back on. Wait until all parts have come to a standstill.
- ▶ When in the hazardous area wear closely fitting clothes with a minimal tear strength.

▲ WARNING Risk of death due to unauthorised switching on

An unauthorised switching on of the power supply during maintenance work results in a risk of severe injury and even death to those persons in the hazardous area.

- ▶ Prior to work starting switch off all power supplies and safeguard against a restart.

▲ WARNING Risk of injury due to incorrectly executed maintenance work

Incorrect maintenance can result in severe injuries and may cause considerable damage to property.

- ▶ Prior to starting work ensure that there is adequate free space for installation.
- ▶ Always include a second person for maintenance activities.
- ▶ Keep the installation site clean and tidy! Loosely stacked or scattered parts and tools can cause accidents.
- ▶ If parts have been removed, ensure that they are assembled correctly, reattach all fixing elements and adhere to the specified thread tightening torques.
- ▶ Prior to a restart, do the following:
 - Ensure that all maintenance work is executed and completed in accordance with the specifications and instructions in this manual.
 - Ensure that no one is present in the hazardous area.
 - Ensure that all covers and safety devices are installed and that they work correctly.

▲ WARNING Risk of death due to hydraulic energy

Hydraulically powered moving parts can cause extremely severe injuries.

- ▶ Only instruct maintenance personnel to conduct work on the hydraulic system.
- ▶ Prior to work on the hydraulic system ensure it is fully de-pressurised. Fully depressurise the pressure accumulator.
- ▶ During operation do not reach into moving parts or handle moving parts.
- ▶ Do not open covers during operation.
- ▶ When in the hazardous area wear closely fitting clothes with a minimal tear strength.

7.1 Maintenance works not allowed by the manufacturer

Some maintenance activities must be carried out exclusively by the manufacturer. If such maintenance activities are required, consult the authorized Customer center / Dealer in your area in order to ensure that they proceed safely.

The following maintenance activities are not allowed by the manufacturer:

- Repairs to the gear and hydraulic motor
- Replacing wear sleeves and pick boxes
- Welding work on the cutter drums
- Welding work on the gear housing

7.2 Maintenance schedule

daily, before and after operation	<p>Cutter drums: Check if all round attack picks exist. Check the round attack picks for wear and play in the pick box. Check the head lengths of all round attack picks for even wear. Check the wear in pick boxes and if necessary the wear sleeves. Check charging spirals for wear. Check cutter drums for jammed steel parts. Note: When cutting abrasive materials (e.g. concrete, sandstone) and additional spraying of the cutter drums with water, it is necessary to reckon with increased wear of the individual pick boxes.</p> <p>Gear: Check for oil leaks. Check the gear for unusual noise. Check the tightness of threaded connections. Check wear plates for wear.</p> <p>Hydraulic motor: Check for oil leaks. Check for overheating. Check the hydraulic motor for unusual noises. Check the tightness of threaded connections.</p> <p>Rotatable upper part: Check the tightness of threaded connections. Check the rotatable upper part for cracks.</p> <p>Hydraulic hoses and fittings: Check the hydraulic hoses for wear and leaks. Check the fittings for leaks and tightness. Check the leakage oil line for contamination. Check the adapter plate for cracks. Check hydraulic lines for leaks and damage. Check the pipe clamp receiver on the carrier.</p>
after shift	Clean drum cutter
weekly	Check the bolted connections at the hydraulic lines and tighten as required.
after the first 50 operating hours	Change hydraulic oil filter cartridge.
after the first 100 operating hours	to be done in a workshop : Change gear oil when you perform heavy cutting operation (e.g. reinforced concrete)
after the first 200 operating hours	to be done in a workshop : Change gear oil when you perform normal cutting operation
every 500 operating hours	Check oil filter cartridge, replace if necessary.
every 1000 operating hours or at least once a year	to be done in a workshop : Change gear oil when you perform heavy cutting operation (e.g. reinforced concrete)
every 2000 operating hours or at least once a year	to be done in a workshop : Change gear oil when you perform normal cutting operation
if necessary	Replace bent and damaged pipes. Replace damaged hoses. Check wear at the adapter plate bolts. Replace round attack picks to be done in a workshop : Replace cutter drums Replace rotatable upper part

7.3 Depressurising the hydraulic system

Even when you have switched off the carrier, a considerable residual pressure can still be present in the hydraulic system.

A residual pressure can still be present in the hydraulic attachment even after you have disconnected the quick-release couplings or closed the shut-off valves.

The hydraulic attachment can only be depressurized using the hydraulic system of the carrier, by allowing hydraulic oil to drain to the tank via the return connection.

Depending on the type of hydraulic attachment, the internal leaks, the oil temperature, the type of hydraulic oil and the design of the hydraulic installation of the carrier, the time required to relieve the pressure can vary.

Observe the following steps in order to depressurise the hydraulic attachment:

1. Ensure that the hydraulic oil in the hydraulic attachment and in the carrier has a temperature of at least 0 °C (32 °F). If necessary, pre-heat it to at least 0 °C (32 °F).
2. The hydraulic attachment must be connected to the hydraulic system of the carrier device, i.e. the hydraulic hoses must be connected up and the respective shut-off valves in the supply pipe and in the connection to the tank must be opened.
3. Place the hydraulic attachment on timber support blocks laying on the ground.
4. Depressurise the hydraulic system according to the manufacturer's safety and operating instructions for the carrier.
5. You must wait at least another 60 minutes until the pressure has been relieved through leakages.
6. When you have made sure that no more pressure is present in the hydraulic system, you must disconnect the hydraulic connection to the carrier. Close the shut-off valves or disconnect the quick-release couplings, so that no hydraulic oil can flow back from the carrier.

7.4 Cleaning

Clean the drum cutter daily after use.

NOTICE Environmental damage due to hydraulic oil

Hydraulic oil is environmentally harmful and must not penetrate the ground or enter the water table or water supplies.

- ▶ Collect any hydraulic oil which escapes.
- ▶ Dispose of it in accordance with the applicable environmental regulations.

NOTICE Damage due to improper cleaning

- ▶ Never strike the round attack picks, cutter drums or the gear with a hard object, e.g. a hammer, in order to free them of a trapped fragment or contaminant.

Note: When cleaning with a high pressure cleaner, be aware of the safety labels. These must not be damaged by a water jet.

- Wipe clean areas to which safety labels are attached by using a cloth.
- Clean all other areas of the drum cutter thoroughly with water.
- Remove contaminations in the intermediate spaces between the round attack picks and pick boxes.
- Ensure that no residual contaminants are located beneath the pick (e.g. fresh concrete or fine material). Such residue could harden and set the picks fast in the boxes.

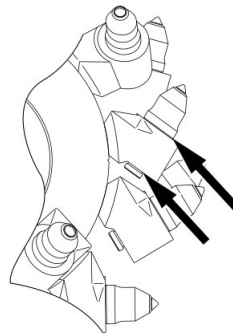

7.5 Checking bolted connections

- Secure the carrier such that it cannot move unexpectedly.
- Check all bolted connections regularly for tight fit (see Chapter **Bolted connections / Tightening torques**).
- Tighten loose bolted connections and hose clamps to the torque required (see Chapter **Bolted connections / Tightening torques**).

7.6 Checking the hydraulic attachment and adapter plate for cracks

- Secure the carrier such that it cannot move unexpectedly.
- Check daily, before and after operation all load-bearing parts and welds of:
 - all the hydraulic attachment,
 - the adapter plate
 for cracks.
- Ensure repair or refinishing in good time to prevent greater damage.

7.7 Checking the adapter plate bolts for wear

- Carry out this visual check whenever the hydraulic attachment has been removed from the carrier.
- Check the adapter plate bolts for excessive wear such as cracks, pitting or severe erosion.
- Rework or replace worn bolts.

7.8 Change gear oil

The following maintenance activities are carried out in the workshop.

▲ **WARNING Risk of injury due to a failure to observe the minimum clearances**

A lack of space for assembly when changing the oil on the drum cutter inside buildings can lead to accidents!

- ▶ When working on the drum cutter inside buildings always ensure sufficient space for assembly.

▲ **WARNING Risk of injury due to oil pressure in the gear**

Loosening the oil filler screw or oil drain plug on the drum cutter too quickly can result in severe injuries.

- ▶ Prior to all work on the hydraulic system depressurise the complete system (see chapter **Depressurising the hydraulic system**) and safeguard it against a restart.
- ▶ Carefully loosen the oil filler screw or oil drain plug and wait for the pressure to drop.

7.8.1 Oil change intervals

The following tables detail the oil change intervals.

Gear oil change	1st interval	2nd interval	Subsequent intervals
With normal cutting operation	200 operating hours	2000 operating hours	Every 2000 operating hours or annually
With heavy cutting operation (e.g. reinforced concrete)	100 operating hours	1000 operating hours	Every 1000 operating hours or annually

7.8.2 Preparation

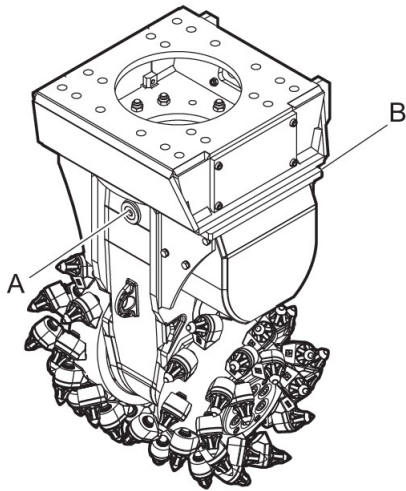

- A. Oil filler screw
- B. Oil drain plug

- Position the drum cutter horizontally on the assembly stand.
- Switch off drum cutter and safeguard.

7.8.3 Drain off gear oil

- Position the oil receiver tank beneath the oil drain plug.

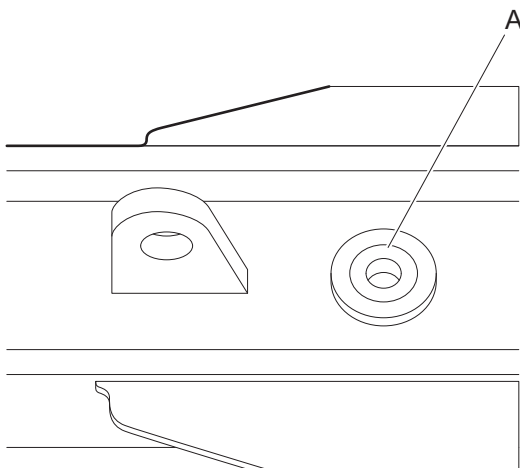

- Carefully loosen the oil filler screw (A) using an Allen key and allow any pressure in the gear to drop.
Any available oil pressure will drop.
- Fully unscrew the oil filler screw (A).

Note: It is important that the oil filler screw (A) is unscrewed first. This allows the oil to run off more quickly and effectively.

- Loosen and unscrew the oil drain plug (B) using an Allen key.

Note: The oil drain plug (B) is located exactly opposite the oil filler screw (A).

- Allow the oil to fully drain off.
- Clean the oil drain plug (B) and opening with a cotton cloth.

Note: The oil drain plug (B) and oil filler screw (A) are fitted with a magnet that attracts metal filings.

- Check the oil drain plug (B) for metal particles, if necessary remove.
- Screw in the oil drain plug (B) and tighten using an Allen key.
- Dispose of used oil in accordance with the applicable environmental regulations.

7.8.4 Fill up gear oil

- Clean the oil filler opening with a cotton cloth.
- Fill up gear oil as per the specifications (see chapter **Media/consumables**). Gear oil volumes (see chapter **Technical specifications**).

Note: It is important to fill until the oil is level with the oil filler screw with the drum cutter in a vertical position (cutter drums down). Always check that the system has been correctly filled with the drum cutter installed on the carrier.

- Clean the oil filler opening with a cotton cloth.
- Screw in the oil filler screw and tighten using an Allen key.
- Clean the drum cutter (see chapter **Cleaning**).

7.9 Check the round attack picks and pick boxes

Check the round attack picks daily, before and after operation.

- Check whether all round attack picks are in place.
- Check the round attack picks, and in particular the tungsten carbide tips for wear and breakages.
The head lengths of the individual round attack picks must be evenly worn, to avoid additional vibrations on the cutter drums.
- If one or more round attack picks are worn, replace them immediately.
- Check movement of round attack picks in the pick boxes. The play of the pick shaft diameter in the pick box must not exceed 0.3- times the pick shaft diameter.

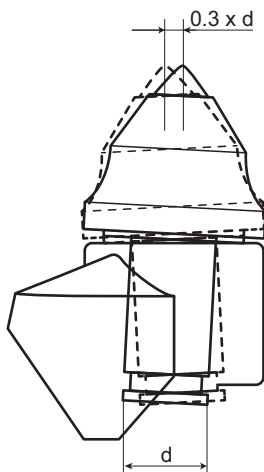

- If one or more round attack picks exhibit play of more than 0.3- times the pick shaft diameter, have the pick box or the wear sleeve immediately replaced.

Contact the authorized Customer Center / dealer in your area.

7.10 Replace round attack picks

- You must replace the round attack picks:
 - if the tungsten carbide tip is worn.
 - if the head lengths of the round attack picks are different.
 - in case of cracks between the shaft and the head.

▲ DANGER Risk of death due to use of old parts

Using old parts (old hydraulic hoses, screws or retainers) can lead to accidents, which may in turn result in severe injuries.

- ▶ Only use new parts.
- ▶ Only use original parts.

Note: There are four different locking systems for the round attack picks. Depending on the design of the drum cutter, the round attack picks can be retained in the pick box with a range of retainers. This also determines the procedure and the tools required to change the part. The four different methods of changing the round attack picks are described in the text that follows.

7.10.1 Replace round attack pick with knock on retainer

The following special equipment is required to replace the round attack picks:

- Mounting tool for knock on retainer
- Dismantling tool for knock on retainer

The special equipment is included in the scope of delivery.

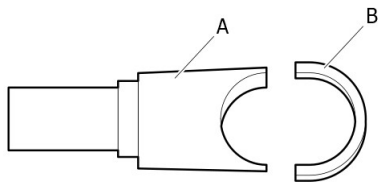

- A. Dismantling tool
B. Knock on retainer

1. Place the dismantling tool (A) with the semi-circular opening onto the opening of the knock on retainer (B).

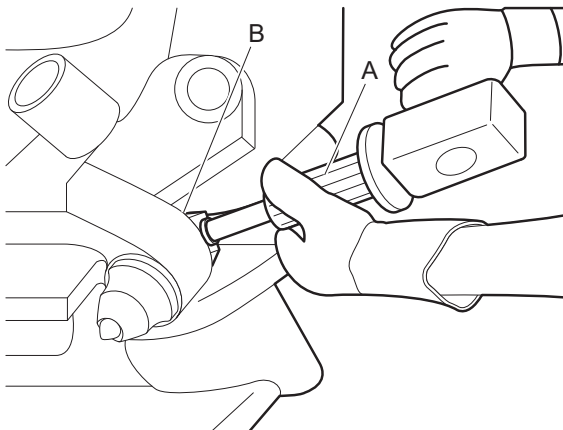

2. Remove the knock on retainer (B) with a forceful hammer blow onto the dismantling tool (A).
3. Pull round attack pick out of the pick box.
4. Clean the pick box.
5. Insert a new round attack pick.
6. Place a new knock on retainer (B) in the mounting tool (C).

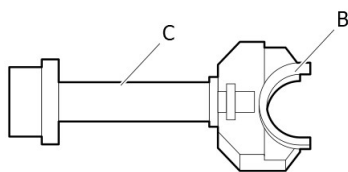

Note: The retainer of the mounting tool is magnetic and holds the knock on retainer.

7. Place the mounting tool with the knock on retainer (B) on the pick shaft (D).

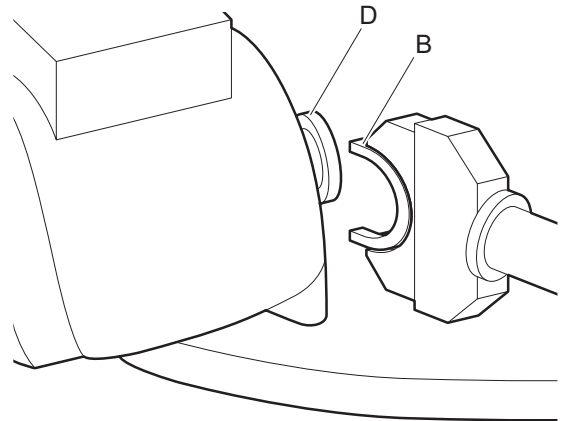

8. Drive in the knock on retainer with a forceful hammer blow onto the mounting tool.

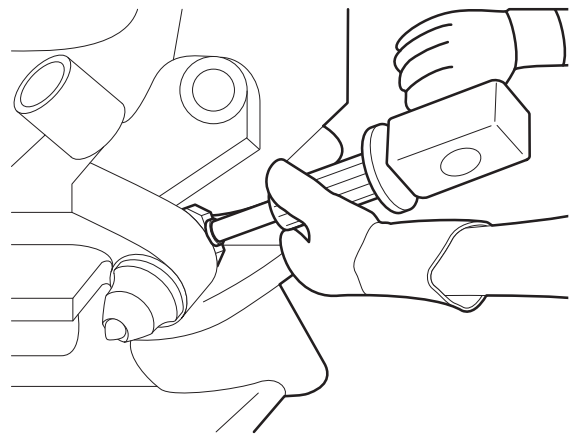

7.10.2 Replace round attack pick with retaining sleeve

The following special equipment is required to replace the round attack picks:

- Puller (E) for pick with retaining sleeve

The special equipment is included in the scope of delivery.

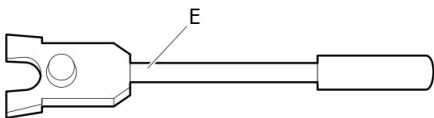

The round attack pick has a notch (see arrow).

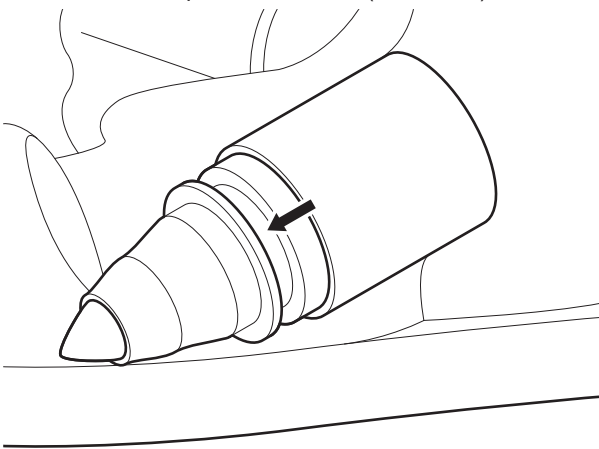

1. Slide the puller (E) into the notch of the round attack pick with the impact surface (F) directed to the cutter drum.

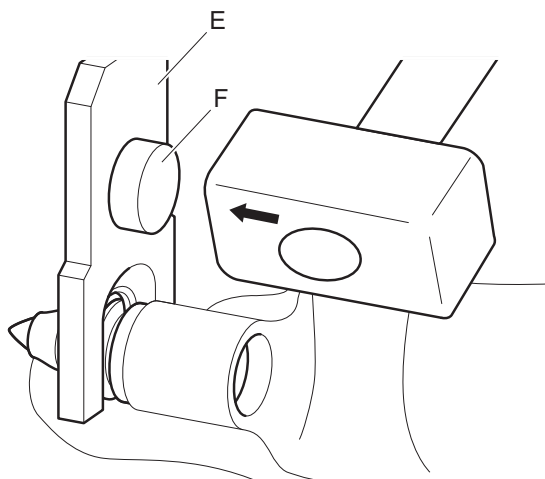

2. Grip the puller (E) firmly in the hand.
3. Give the impact surface (F) of the puller (E) a forceful blow with a hammer.

The round attack pick will loosen from the pick box.

4. Pull round attack pick out of the pick box.

5. Clean the pick box.
6. Place a new round attack pick (G) in the notch of the puller. The tip of the pick must point in the direction of the impact surface (F).

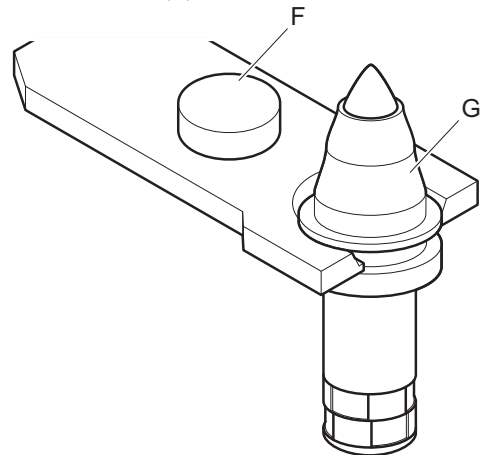

7. Place the new round attack pick in the puller and place in the opening of the pick box (H).

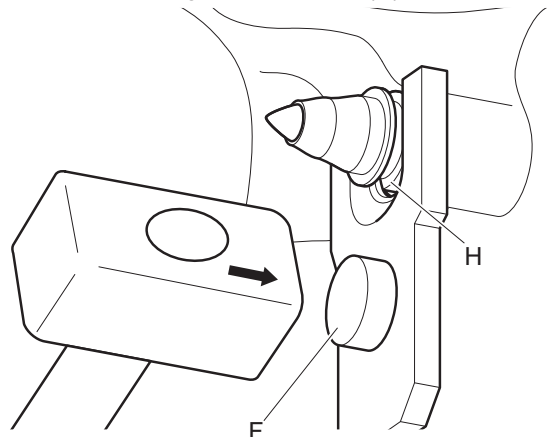

8. Give the impact surface (F) of the puller a forceful blow with a hammer.

The round attack pick is anchored in the pick box by the retaining sleeve on the shaft.

7.10.3 Replace round attack picks with quick snap retainer

The following special equipment is required to replace the round attack picks:

- Puller tool for pick with quick snap retainer

The special equipment is included in the scope of delivery.

1. Place the curved tip of the puller tool into the hole in the quick snap ring (I).

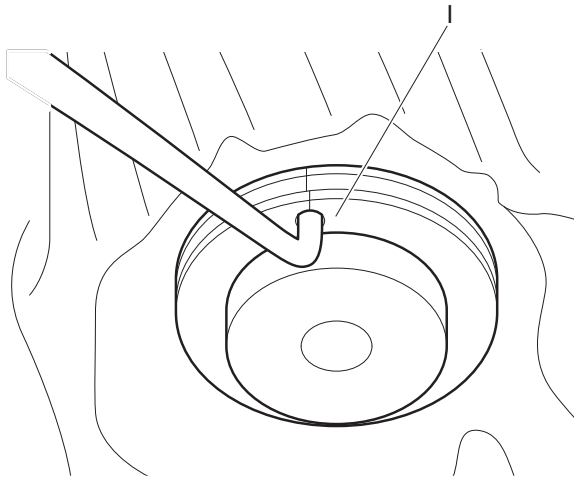

2. Grip the puller tool firmly in the hand and pull it upwards (see arrow).>

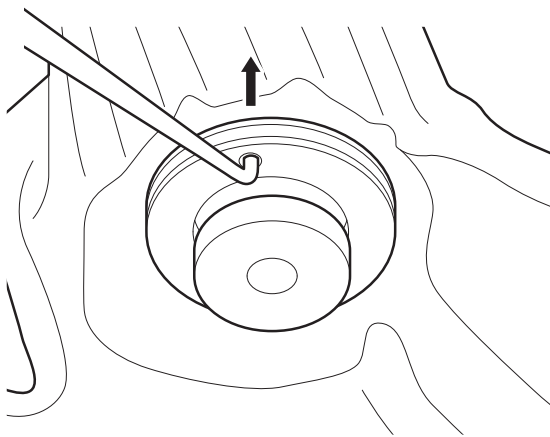

The quick snap retainer loosens from the shaft of the round attack pick.

3. Pull round attack pick out of the pick box.
4. Clean the pick box.
5. Slide a new round attack pick (J) into the pick box (K) (see arrow).

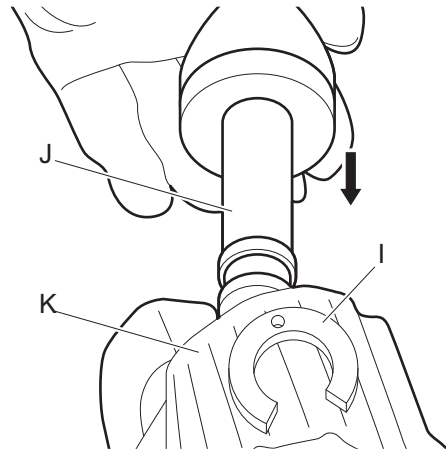

6. Position the new quick snap retainer (I) with the opening downwards on the shaft of the round attack pick (J) and apply firm pressure (see arrow).

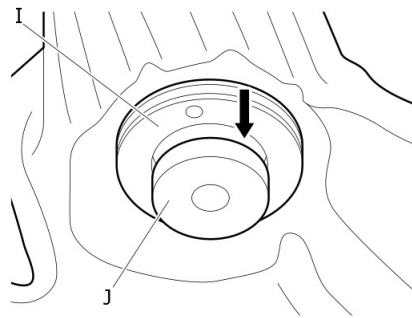

The quick snap retainer slides on to the pick shaft and secures it.

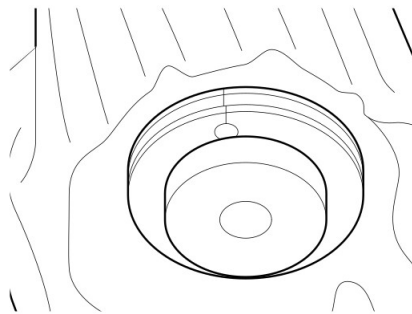

7.10.4 Replace round attack picks with retaining ring

The following special equipment is required to replace the round attack picks:

- Long nose pliers, curved

1. Remove both retaining rings (L) from the pick shaft one after another using long nose pliers (M).

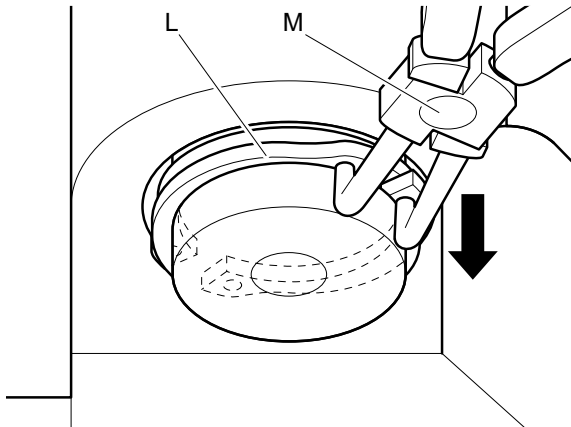

2. Pull round attack pick out of the pick box.
3. Clean the pick box.
4. Insert a new round attack pick.
5. Place a new retaining ring (L) on the pick shaft (N) and rotate the retaining ring opening downwards (arrow).

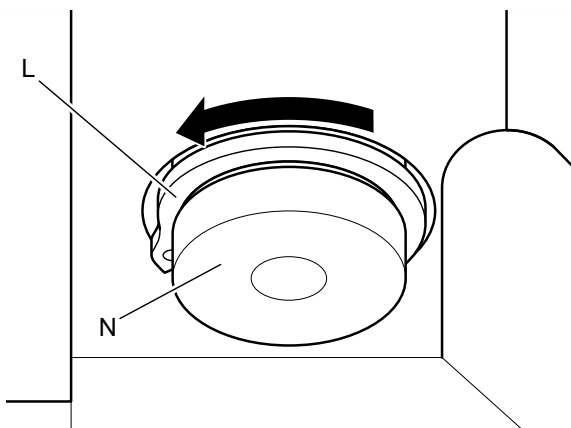

6. Attach the second retaining ring (L) and rotate the retaining ring opening upward.

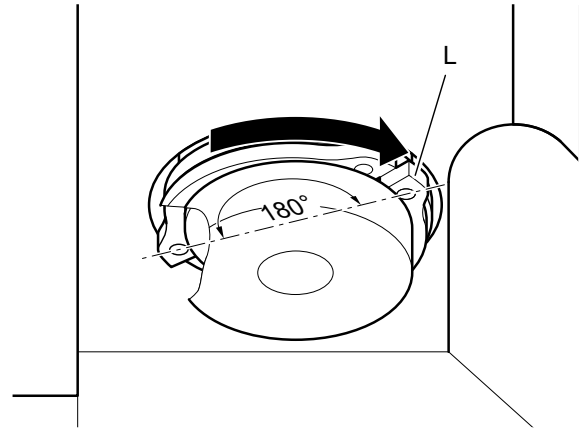

7.11 Replace cutter drums

The following maintenance activities are carried out in the workshop.

- You must replace the cutter drums:
 - if the bearing surfaces of the pick boxes are worn.
 - if the pick boxes are worn in the area of the snap rings.
 - if the pick boxes are broken.
 - if the wear condition of the charging spiral is irreparable.

▲ DANGER Risk of death due to use of old parts

Using old parts (old hydraulic hoses, screws or retainers) can lead to accidents, which may in turn result in severe injuries.

- ▶ Only use new parts.
- ▶ Only use original parts.

Note: You need an assistant who supports you during assembly and disassembly work when changing the cutter drums.

▲ WARNING Risk of injury due to negligence or incorrect lifting procedure

Negligent or incorrect actions during the lifting of the cutter drums can cause severe injuries.

- ▶ When lifting or lowering the cutter drums, always be aware of the weight.
- ▶ Always execute all lifting procedures with heavy parts using suitable lifting gear.
- ▶ If lifting procedures require the application of physical force, personnel should always lift in pairs.
- ▶ Wear protective gloves and safety footwear.

7.11.1 Disassemble cutter drums

1. Disassemble drum cutter from carrier (see chapter **Removing the hydraulic attachment from the carrier**) and place on a level working area with sufficient bearing strength.
2. Secure the drum cutter against falling using suitable lifting equipment and suspend on a crane. When doing so always observe the weight (see chapter **Technical Specifications**).
3. Keep the lifting equipment tight.
4. Loosen the threaded connections of the cutter drum (A).

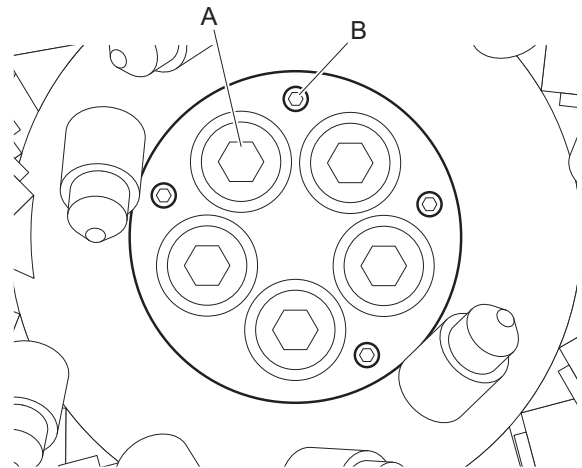

5. Remove the clamping sleeves (C) in the drive shaft using a special extractor (D).

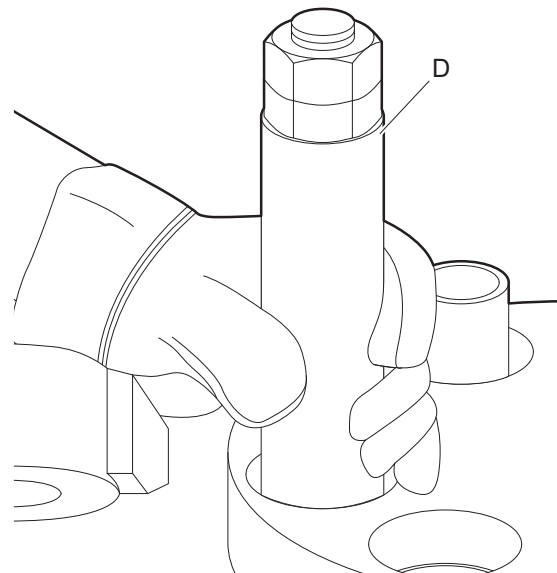

6. Screw in the dismounting bolts (B).
Screwing in the dismounting bolts (B) results in the cutter drum being pushed away from the drive shaft.
7. The cutter drum, once loosened from the drive shaft, must be secured against rocking movements by an assistant.
8. Carefully lift the cutter drum away from the drive shaft and set down.

7.11.2 Assemble cutter drums

Note: In order to ensure safe and optimum cutting behaviour always mount the cutter drums in a symmetrical situation in relation to the pick boxes.

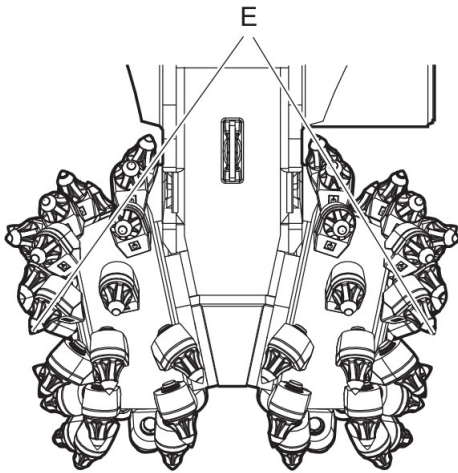

■ Mount the cutter drums symmetrically to each other (E).

1. Lay the drum cutter with disassembled cutter drums on the side using a crane.

2. Suspend cutter drum (F) on a crane using suitable lifting equipment and always observe the weight.

Note: Suitable lifting lugs can be screwed into the threads of the disassembly screws in order to lift the cutter drum.

3. Carefully set the cutter drum down on the drive shaft (G) of the drum cutter.

Note: Crane to be operated by an assistant.

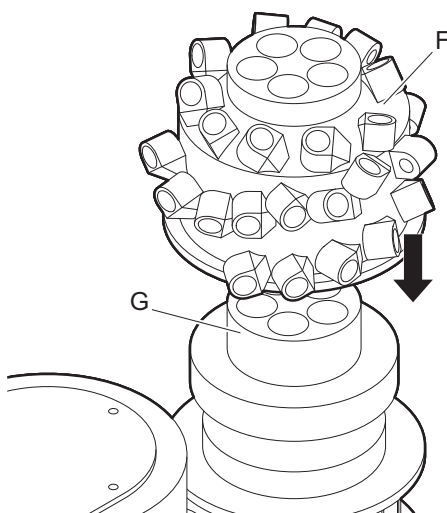

4. Insert the clamping sleeves with the opening (slit) (H) opposite to the turning direction (see arrow) of the cutter drum.

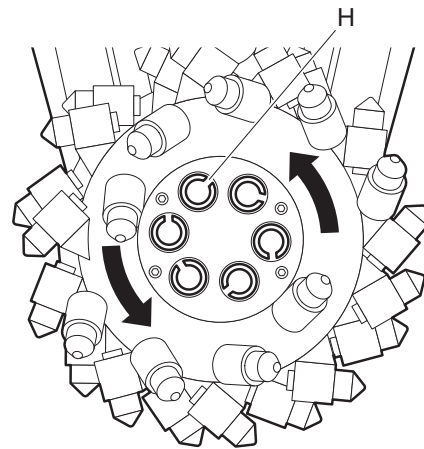

5. Drive in the positioned clamping sleeves (C) with the mandrel (I) until they are flush with the bearing surface.

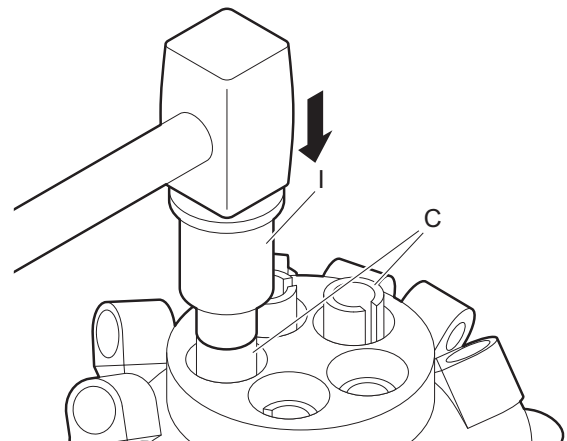

6. Insert special washers (J).

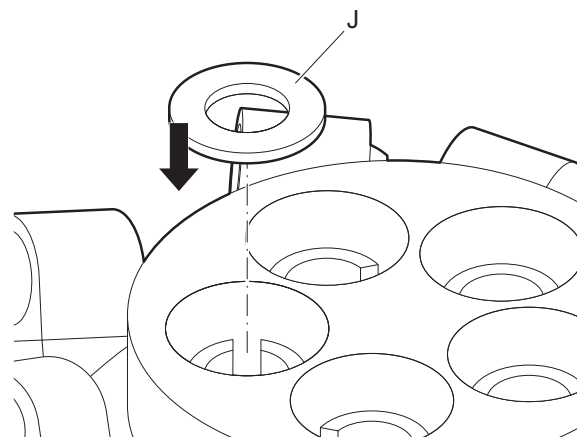

7. Apply locking adhesive (K) (e.g. Loctite 243) to the fixing screw threads and screw in.

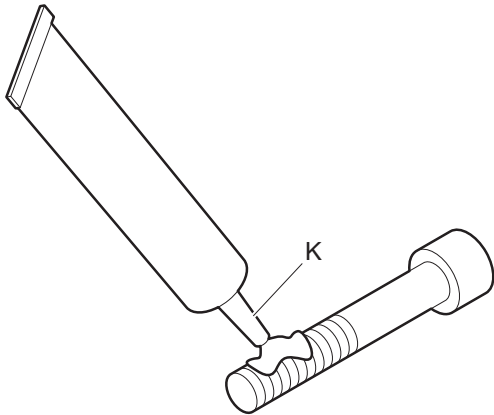

8. Screw in the disassembly screws without locking adhesive in order to protect the threads.

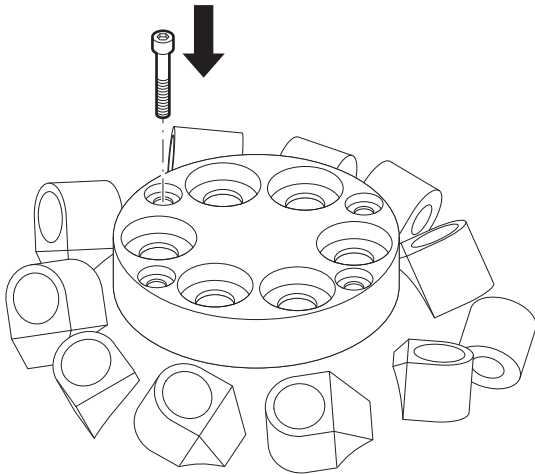

▲ WARNING Risk of fatal injury due to a failure to observe the requisite tightening torques

Accidents can happen due to negligence and these can lead to severe injuries or damage to property.

- ▶ Tighten the cutter drums with the requisite tightening torque.

9. Tighten the fixing screws with the requisite tightening torque in a diagonal sequence.

Type	Tightening torque for the fixing screws
VC 1400	560 Nm (413 ft lbs)
VC 2000	1400 Nm (1033 ft lbs)
VC 3000	1400 Nm (1033 ft lbs)

10. Mount the round attack picks (see chapter **Replace round attack picks**).

7.12 Assemble and disassemble intermediate bracket

The following maintenance activities are carried out in the workshop.

▲ WARNING Risk of injury due to negligence or incorrect lifting procedure

Negligent or incorrect actions during the lifting of the intermediate bracket can result in severe injuries.

- ▶ When lifting or lowering the intermediate bracket, always observe the weight.
- ▶ Always execute all lifting procedures with heavy parts using suitable lifting gear.
- ▶ If lifting procedures require the application of physical force, personnel should always lift in pairs.
- ▶ Wear protective gloves and safety footwear.

Note: You need an assistant who supports you when disassembling and assembling the intermediate bracket.

7.12.1 Disassemble intermediate bracket

Note: To lift the intermediate bracket you need two eye nuts M30 DIN 582 and screws M30x50 - 8.8 DIM 912 or DIN 933.

1. Remove the adapter plate (see chapter **Removing the hydraulic attachment from the carrier**).
2. Lift the drum cutter onto the assembly stand.
3. Fit two eye nuts (A) into the intermediate bracket and secure with screws (B).

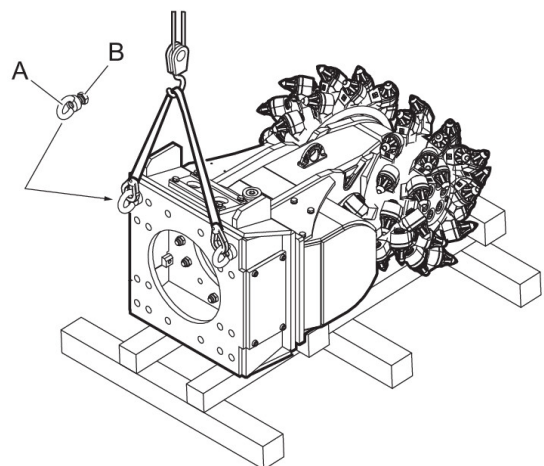

4. Attach lifting equipment to lift the intermediate bracket with a crane.
5. Remove the screws (D) and pair of lock washers (C).

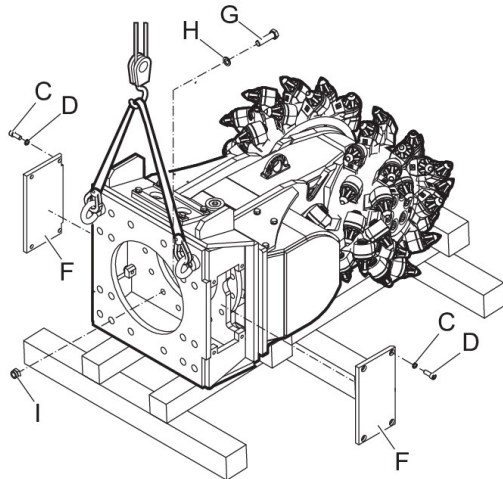

6. Remove the covers (F).
7. Remove the hexagon head bolts (G), pair of lock washers (H) and nuts (I).
8. Keep all parts for further use.
9. Lift up the intermediate bracket and set down carefully on squared timbers or a pallet.

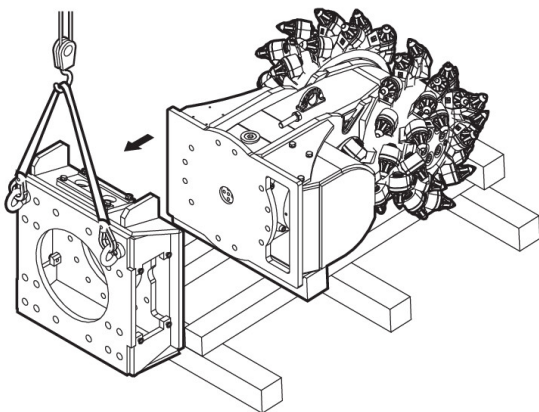

7.12.2 Assemble intermediate bracket

▲ WARNING Risk of injury due to a failure to observe the requisite tightening torques

A failure to observe the tightening torques can result in accidents which may lead in turn to severe personal injuries or damage to property.

► Tighten the drum cutter with the requisite tightening torque.

1. Lift the intermediate bracket with a crane and adjust it to the drum cutter.

▲ WARNING Hands and fingers being cut off or hurt

Bores and surfaces can act like a pair of scissors and cut off or hurt parts of your body.

► Never use your fingers to check bores or fitting surfaces.

2. Ensure that the hole patterns of the intermediate bracket and the drum cutter align with each other.
3. Fit a pair of lock washers (H) to each hexagon head bolt (G) and fix with nuts (I).
4. Tighten with the required tightening torque.

Type	Size	Tightening torque
VC 1400	30 mm (1.18 in.)	415 Nm (306 ft lbs)
VC 2000	36 mm (1.42 in.)	714 Nm (527 ft lbs)
VC 3000	46 mm (1.81 in.)	1428 Nm (1053 ft lbs)

5. Remove the eye nuts (A) and lifting equipment.
6. Fit the covers (F).
7. Fit a pair of lock washers (C) to each screw (D).
8. Tighten with the required tightening torque.

Type	Size	Tightening torque
VC 1400	10 mm (0.39 in.)	90 Nm (66 ft lbs)
VC 2000	14 mm (0.55 in.)	170 Nm (125 ft lbs)
VC 3000	14 mm (0.55 in.)	170 Nm (125 ft lbs)

7.13 Assemble and disassemble rotatable upper part

The following maintenance activities are carried out in the workshop.

▲ DANGER Risk of death due to use of old parts

Using old parts (old hydraulic hoses, screws or retainers) can lead to accidents, which may in turn result in severe injuries.

- ▶ Only use new parts.
- ▶ Only use original parts.

▲ WARNING Risk of injury due to negligence or incorrect lifting procedure

Negligent or incorrect actions during the lifting of the rotatable upper part can result in severe injuries.

- ▶ When lifting or lowering the rotatable upper part, always observe the weight.
- ▶ Always execute all lifting procedures with heavy parts using suitable lifting gear.
- ▶ If lifting procedures require the application of physical force, personnel should always lift in pairs.
- ▶ Wear protective gloves and safety footwear.

Note: You need an assistant who supports you when disassembling and assembling the rotatable upper part.

If you want to mount a rotatable upper part instead of the intermediate bracket you additionally need following parts:

- Centering pin
- Fastening plate
- Screws

This parts are not in the scope of delivery. You can order them as optional parts.

7.13.1 Disassemble rotatable upper part

1. Remove the adapter plate (see chapter **Removing the hydraulic attachment from the carrier**).
2. Lift the drum cutter onto the assembly stand.

3. Attach lifting equipment to the rotatable upper part (C) and keep this tight.

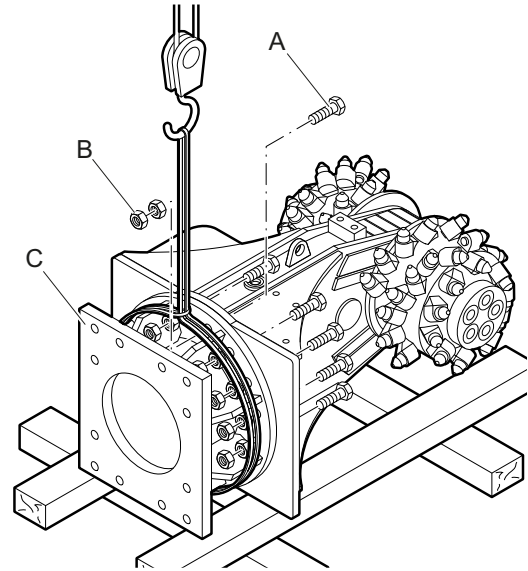

4. Remove the screws (A) and nuts (B).
5. Remove the screws (D) and the fastening plate (E) of the centre bolt.

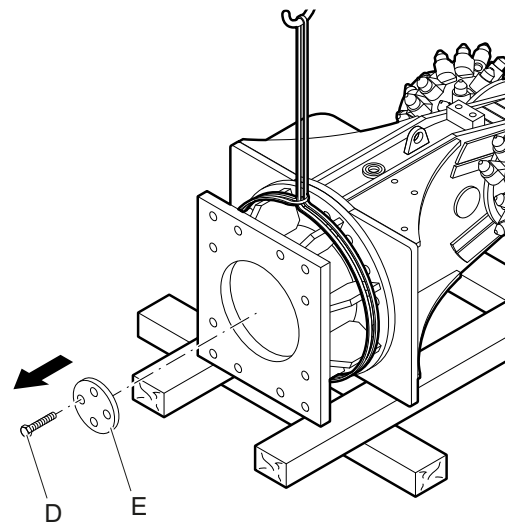

6. Lift up the rotatable upper part and set down carefully on squared timbers or a pallet.

7.13.2 Assemble rotatable upper part

▲ WARNING Risk of injury due to a failure to observe the requisite tightening torques

A failure to observe the tightening torques can result in accidents which may lead in turn to severe personal injuries or damage to property.

► Tighten the drum cutter with the requisite tightening torque.

1. Lift the rotatable upper part with a crane and place on the drum cutter and adjust on the centre bolt (F).

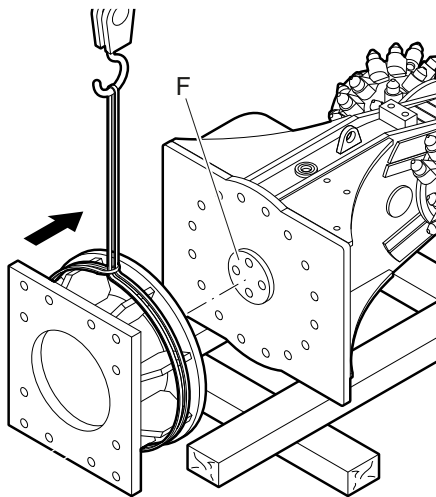

▲ WARNING Hands and fingers being cut off or hurt

Bores and surfaces can act like a pair of scissors and cut off or hurt parts of your body.

► Never use your fingers to check bores or fitting surfaces.

2. Ensure that the hole patterns of the rotatable upper part and the drum cutter align with each other.

3. Attach the fastening plate (E) of the centre bolt and fix with the screws (D).

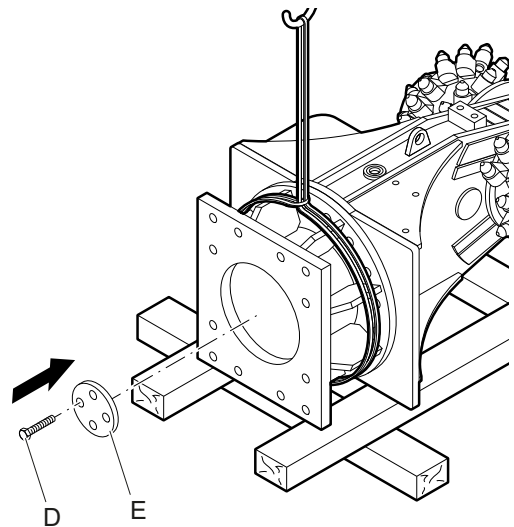

4. Insert the screws (A), put a nut (B) onto each screw and tighten.

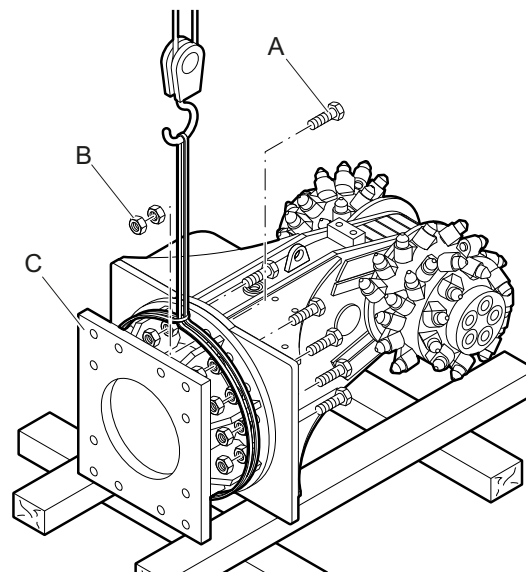

Type	Size	Tightening torque
VC 1400	30 mm (1.18 in.)	415 Nm (306 ft lbs)
VC 2000	36 mm (1.42 in.)	714 Nm (527 ft lbs)
VC 3000	46 mm (1.81 in.)	1428 Nm (1053 ft lbs)

5. Put counter nuts (B) on the screws and tighten.

7.14 Checking hydraulic lines

- Secure the carrier such that it cannot move unexpectedly.
- Perform a visual inspection of all lines (pipes and hoses) from the pump to the hydraulic attachment and back to the tank, before starting work.
- Tighten loose bolted connections and hose clamps to the torque required (see Chapter **Bolted connections / tightening torques**).
- Replace damaged pipes and/or hoses.

7.15 Checking and cleaning the hydraulic oil filter of the carrier

An oil filter must be integrated in the return circuit of the hydraulic system. The maximum mesh width allowed for the oil filter is 50 microns; it must have a magnetic separator.

- Secure the carrier such that it cannot move unexpectedly.
- Change the oil filter cartridge after the first 50 operating hours.
- Check the oil filter **every** 500 operating hours and replace if it is necessary.

7.16 Replace hydraulic hoses

- Replace the hydraulic hoses:
 - if they are more than six years old.
 - if the outer layer is damaged.
 - if they become brittle or deformed.
 - if the hose fitting is deformed or damaged.
 - if they loosen from the fittings.

▲ **WARNING Risk of injury due to high pressure in the hydraulic circuit**

High pressures are present in the hydraulic circuit, which can cause bursts in the event of a failure to observe the specifications, and thus lead to serious injuries.

- ▶ Prior to all work, depressurise hydraulic devices and lines and safeguard against a restart (see chapter **Depressurising the hydraulic system**).
- ▶ Do not tighten screw connections which are under pressure.
- ▶ Always use the requisite personal protective gear.
- ▶ Always use hydraulic lines which are intended for the respective purpose.
- ▶ Always install hydraulic lines correctly and protect these against mechanical and thermal damage.
- ▶ Do not exceed the nominal pressure for the hydraulic lines.

▲ **DANGER Risk of death due to use of old parts**

Using old parts (old hydraulic hoses, screws or retainers) can lead to accidents, which may in turn result in severe injuries.

- ▶ Only use new parts.
- ▶ Only use original parts.

Note: When working on the hydraulic circuit, always have suitable oil receiver tanks available and collect oil for environmental reasons.

Note: When changing the hydraulic hoses, always use the manufacturer's original parts exclusively.

- Remove the motor cover from the drum cutter.
- Clean the immediate environment around the hydraulic hose connections requiring replacement.
- Loosen the threaded connections on the hydraulic hose fittings.
- Loosen the hose fittings on the carrier.
- Remove the hydraulic hose and insert end caps into all fitting openings.

- Unscrew the end cap from one side of the new hydraulic hose.
- Place a new hydraulic hose on the fitting.
- Tighten the new hydraulic hose (see chapter **Bolt connections / Tightening torques**).
- Fit the motor cover to the drum cutter.

7.17 Actions following maintenance

After completing the maintenance work and prior to switching on the hydraulic attachment carry out the following steps:

- Check that all previously loosened threaded connections have been tightened.
- Check that all previously removed safety devices and covers have been replaced in an orderly manner.
- Ensure that all tools, materials and other equipment used have been removed from the working area.
- Clean the working area and remove spilled substances such as liquids, processing materials and similar.
- Ensure that all safety devices on the hydraulic attachment are fully functional.
- Ensure that the stipulated prerequisites for the carrier have been fulfilled (see chapter **Preconditions for the carrier**).

7.18 Bolt connections / Tightening torques

The bolt connections of drum cutters are subjected to very high loads.

- Tighten any loose connections so that the tightening torques are maintained.

Connection point	Interval	VC 1400			VC 2000			VC 3000			
		Type of spanner / size Tightening torque									
Adapter plate (fixing bolts)	A	daily	Allen key / 22 mm (0.87 in.) 1500 Nm (1106 ft lbs)								
Rotatable upper part (fixing bolts)	B	in case of re- pair	open-ended wrench								
			30 mm (1.18 in.) 415 Nm (306 ft lbs)	36 mm (1.42 in.) 714 Nm (527 ft lbs)	46 mm (1.81 in.) 1428 Nm (1053 ft lbs)						
Motor cover (fixing bolts)	C	if necessary	open-ended wrench								
			24 mm (0.95 in.) 190 Nm (140 ft lbs)							30 mm (1.18 in.) 400 Nm (295 ft lbs)	
Cutter drum (fixing bolts)	D	if necessary	Allen key 17 mm (0.67 in.) 560 Nm (413 ft lbs)			Allen key 19 mm (0.75 in.) 1400 Nm (1033 ft lbs)					
Overpressure cover (fixing bolts)	E	in case of re- pair	open-ended wrench 24 mm (0.95 in.) 190 Nm (140 ft lbs)			open-ended wrench 30 mm (1.18 in.) 400 Nm (295 ft lbs)					
Hydraulic ports* pressure line and tank line	F	weekly	Hand-tighten and then tighten a quarter turn with the wrench								
Hydraulic port* leakage oil	G	weekly	Hand-tighten and then tighten a quarter turn with the wrench								
Cover (fixing bolts)	H	if necessary	-			open-ended wrench					
						24 mm (0.95 in.) 190 Nm (140 ft lbs)				30 mm (1.18 in.) 400 Nm (295 ft lbs)	

* valid only for metric standard hose set

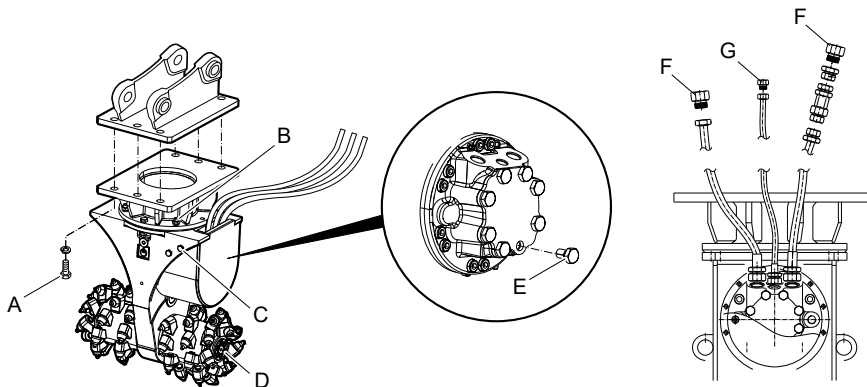

8 Troubleshooting

The following chapter describes the possible causes of faults and the procedures to repair them.

- In the event of multiple faults arising, reduce the maintenance intervals in line with the actual load on the system.
- In the event of faults which cannot be eliminated by following the instructions below, consult the authorized Customer Center / Dealer in your area.

▲ **WARNING** Danger of injury due to moving parts

Rotating components and/or components with linear motions can cause serious injury.

- ▶ Prior to all troubleshooting work on moving parts switch the machine off and safeguard it against being switched back on. Wait until all parts have come to a standstill.
- ▶ When in the hazardous area wear closely fitting clothes with a minimal tear strength.

▲ **WARNING** Risk of death due to unauthorised switching on

An unauthorised switching on of the power supply during fault-finding and troubleshooting results in the risk of severe injuries and even death to persons in the hazardous area.

- ▶ Prior to work starting switch off all power supplies and safeguard against a restart.

▲ **WARNING** Risk of injury due to unprofessional troubleshooting

The unprofessional execution of troubleshooting work can lead to severe injuries and considerable damage to property.

- ▶ Prior to starting work ensure that there is adequate free space for installation.
- ▶ Ensure order and cleanliness at the installation site. Loosely stacked or scattered parts and tools can cause accidents.
- ▶ If parts have been removed, ensure that these are assembled correctly, reattach all fixing elements and adhere to the specified thread tightening torques.
- ▶ Prior to a restart, ensure the following:
 - Ensure that all troubleshooting work is carried out and completed in accordance with the specifications and instructions in this manual.
 - Ensure that no one is present in the hazardous area.
 - Ensure that all covers and safety devices are installed and that these function correctly.

▲ **WARNING** Risk of injury due to hot surfaces

During operation, individual parts of the carrier or drum cutter can become very hot and cause burns.

- ▶ Before commencing with troubleshooting, allow hot parts to cool to the ambient temperature.
- ▶ Wear heat-resistant gloves.

Actions in the event of faults

The following always applies:

1. With faults which present an immediate danger to personnel or property, initiate an emergency stop immediately.
2. Determine the cause of the fault.
3. If troubleshooting requires work in the hazardous area, switch off the machine and safeguard it against a restart. Immediately inform the responsible parties at the installation site of the fault.
4. Depending on the nature of the fault, have this repaired by a specialist or repair it independently.

The faults table that follows provides details on who is authorised to repair the various faults.

8.1 Faults table

Refer to the operating instructions for the carrier in the event of faults, and in particular when troubleshooting. If the remedial measures described here do not eliminate the fault or faults occur which are not listed here, consult the authorized Customer Center / Dealer in your area immediately.

8.2 Cutter drums do not turn / are blocked

Cause	Remedy	By
Cutting material trapped between cutter drum and gear or bearing housing	Shut down machine, depressurise and safeguard against a restart. Remove trapped cutting material. Allow cutter to run in reverse briefly.	Carrier driver
	Disassemble cutter drums	Workshop
Hydraulic pump pressure is too low	Increase pressure via the excess pressure valve and observe the max. values.	Carrier driver
No oil pressure	Check hydraulic pump and valves.	Carrier driver
Damage to the internal parts of the hydraulic motor	Consult the authorized Customer Center / Dealer in your area. Rinse leakage oil line. Exchange hydraulic motor. Replace tank line / leakage oil filter cartridge.	Authorized Customer Center / Dealer in your area
Damage to the internal parts of the gear	Consult the authorized Customer Center / Dealer in your area. Dismantle gears. Replace damaged parts.	Authorized Customer Center / Dealer in your area
Check valve installed inverted	Install check valve as per hydraulic installation plan version 1.	Workshop
Hydraulic couplings of the hoses are blocked or excavator valve on boom not completely opened	Check hydraulic couplings. Open excavator valve.	Carrier driver

8.3 Cutter drums turn too slowly

Cause	Remedy	By
Hydraulic pump delivery volume too low	Increase delivery volume.	Carrier driver
	Replace hydraulic motor with a motor recommended by the authorized Customer Center / Dealer in your area with a lower displacement volume.	Authorized Customer Center / Dealer in your area
Poor efficiency of the pump for the hydraulic motor	Replace hydraulic motor or pump.	Authorized Customer Center / Dealer in your area
Oil leaks between hydraulic pump and hydraulic motor	Replace damaged hydraulic hoses. Tighten connection elements.	Workshop
Hydraulic couplings of the hoses are blocked or excavator valve on boom not completely opened	Check hydraulic couplings. Open excavator valve.	Carrier driver

8.4 Drum cutter stops moving with light pressure

Cause	Remedy	By
Carrier operating pressure too low	Check operating pressure and adjust to recommended value.	Carrier driver

8.5 Unusual oscillation of the cutter drums

Cause	Remedy	By
Round attack picks worn, damaged or round attack picks with different length mounted	Replace round attack picks.	Carrier driver

8.6 Round attack picks do not turn

Cause	Remedy	By
Corrosion, cutting material or fine material between pick shaft and pick box	Following extended storage disassemble round attack picks. Clean pick shafts after finishing work and spray with a creeping corrosion protection spray. In case of difficult work (cutting asphalt) consult the authorized Customer Center / Dealer in your region.	Workshop

8.7 Unusually loud gear noise

Cause	Remedy	By
Damage to internal gear parts	Consult the authorized Customer Center / Dealer in your region and replace gear.	Authorized Customer Center / Dealer in your area

8.8 Unusually loud noise from the hydraulic motor

Cause	Remedy	By
Air inclusions in the hydraulic circuit or motor	Bleed the system.	Carrier driver
Too little pressure backed up in the tank line	Execute hydraulic installation as per version 1.	Authorized Customer Center / Dealer in your area
Damage to internal parts due to foreign matter	Consult the authorized Customer Center / Dealer in your area. Rinse tank line. Replace tank line filter cartridge.	Authorized Customer Center / Dealer in your area
Leakage oil line blocked	Install leakage oil line as per hydraulic installation version 1 or 2 and measure oil pressure.	Workshop

8.9 Overpressure cover for the hydraulic motor deformed, oil leak on sealing surface, oil leak at the pressure limiting valve

Cause	Remedy	By
Pressure in the leakage oil line too high. Leakage oil line not installed separately, leakage oil filter not maintained, shut-off valve in the leakage oil line closed, plug coupling not correctly latched.	Install leakage oil line as per hydraulic installation version 1 or 2 and measure oil pressure.	Workshop

8.10 Oil leaking at the cutter drum area

Cause	Remedy	By
Slide ring seals on output shaft damaged / high pressure seal between hydraulic motor and gear leaking	Change set of slide ring seals. Change high pressure seal between hydraulic motor and gear.	Authorized Customer Center / Dealer in your area

8.11 Behaviour following fault elimination

After correcting the fault execute the following steps to start up again:

1. Reset the emergency stop devices.
2. Acknowledge the fault on the controller.
3. Ensure that no one is present in the hazardous area.
4. Start in accordance with the instructions in the chapter **Preparations before starting**.

9 Repair

- For technical support contact the authorized Customer Center / Dealer in your area.

9.1 Sending in the hydraulic attachment for repairs

NOTICE Mixed hydraulic oil

Never mix mineral and non-mineral hydraulic oils! Even small traces of mineral oil mixed in with non-mineral oil can result in damage to both the hydraulic attachment and the carrier. Non-mineral oil loses its biodegradability.

- ▶ Only use one type of hydraulic oil.
- Always specify which hydraulic oil has been used when sending in the hydraulic attachment to have it repaired.

10 Storage

10.1 Drum cutter

10.1.1 Short storage

Proceed as follows in the case of storage for less than three months:

- Remove the drum cutter from the carrier (see chapter **Removing the hydraulic attachment from the carrier**).
- Always store the drum cutter:
 - secured on the assembly stand
 - dry, free of dust and free of contamination
 - free of mechanical shocks
 - protected from mechanical damage
- Check the general condition of all parts and the packaging regularly.

10.1.2 Long storage

For storage of more than 3 months extra procedures must be performed in addition to short storage.

In order to guarantee protection of the internal parts of the hydraulic motor, implement the following protective measures with respect to the hydraulic motor:

The measures listed in the following table depend on the duration of storage and the ambient climate of the storage site.

Duration of storage	Climate range		
	Moderate	Tropical	Coastal
3 months	A	B	C
6 months	B	C	D
12 months	C	C	D
24 months	C	D	D

Explanation to the measures specified in the table pertaining to storage:

A	No special maintenance measures necessary. Apply plugs and closures.
B	Fill hydraulic motor with hydraulic oil.
C	Rinse hydraulic motor with preservation agent.

D	Fill hydraulic motor with preservation agent.
---	---

10.2 Cutter drums

- Remove the round attack picks, if the cutter drums are stored for an extended period, (see chapter **Replace round attack picks**).
- Preserve the cutter drums with oil.

10.3 Round attack picks

If the drum cutter is stored for an extended period, detach the round attack picks because these can corrode with the cutting material and bond together with the pick boxes.

- Remove the round attack picks (see chapter **Replace round attack picks**).
- Preserve the round attack picks with oil.
- Store the round attack picks protected against contamination and mechanical damage.

NOTICE Damage due to increased wear

Dust and dirt adhere to oily surfaces and lead to increased wear.

- ▶ Clean oiled parts before reassembly.

11 Disposal

▲ **WARNING Risk of injury due to improper disassembly**

Stored residual energy, sharp-edged parts, pointed tips and corners on or in the machine or on the requisite tools can cause injuries.

- ▶ Prior to starting work ensure that there is adequate free space.
- ▶ Handle parts with exposed sharp-edges carefully.
- ▶ Ensure order and cleanliness at the place of work! Loosely stacked or scattered parts and tools can cause accidents.
- ▶ Disassemble parts correctly. Be aware of the weight of parts. These may be heavy. If necessary use lifting gear.
- ▶ Secure parts so that they do not fall or topple.
- ▶ Consult the authorized Customer Center / dealer in your area in case of ambiguities.

NOTICE Environmental damage due to consumables

Hydraulic and gear oil are environmentally harmful and must not penetrate the ground or enter the water table or water supplies.

- ▶ Collect any such consumables which may escape.
- ▶ Dispose of them in accordance with the applicable environmental regulations.

11.1 Drum cutter

- Switch off the drum cutter and secure against a restart.
- Remove the drum cutter from the carrier (see chapter **Removing the hydraulic attachment from the carrier**).
- Remove the adapter plate (see chapter **Removing the hydraulic attachment from the carrier**).
- Remove the hydraulic hoses from the drum cutter.
- Clean the drum cutter (see chapter **Cleaning**).
- Dispose of the drum cutter in line with all applicable regulations or consult an authorised and specialised recycling company.

11.2 Hydraulic hoses

- Drain the hydraulic oil from the hydraulic hoses and collect it.

- Dispose of the hydraulic hoses in accordance with the applicable regulations to avoid environmental hazards.

11.3 Hydraulic oil

- Collect any hydraulic oil that escapes.
- Dispose of it in accordance with the applicable environmental regulations.

11.4 Gear oil

- Collect any gear oil which escapes.
- Dispose of it in accordance with the applicable environmental regulations.

12 Technical specifications

Type	VC 1400-1	VC 1400-2	VC 1400-3
Carrier weight class ¹	15 - 25 t (33000 - 55000 lbs)		
Service weight ²	1400 kg (3086 lbs)		
Weight without adapter ³	1200 kg (2645 lbs)		
Dimensions			
Total length	1260 mm (49.6 in.)		
Total width of cutter drums	920 mm (36.2 in.)		
Diameter of cutter drum	585 mm (23 in.)		
Nominal power	80 kW (107 hp)		
Oil flow rate idling, max.	200 l/min (52.8 gal (US)/min)		
Oil flow rate, recommended at 200 bar (2900 psi)	120 l/min (31.7 gal (US)/min)	150 l/min (39.6 gal (US)/min)	170 l/min (44.9 gal (US)/min)
Operating pressure, max.	350 bar (5075 psi)		
Rotational speed, recommended	80 rpm		
Pick speed	2.4 m/s (7.9 fps)		
Number of picks	60		
Pick shaft diameter	30 mm (1.18 in.)		
Maximum cutting force at 350 bar (5075 psi)	28.4 kN (6384 lbf)	35.6 kN (8003 lbf)	39.0 kN (8767 lbf)
Maximum torque at 350 bar (5075 psi)	8.3 kNm (6122 ft lbs)	10.4 kNm (7671 ft lbs)	11.4 kNm (8408 ft lbs)
Maximum rock hardness	60 Mpa (8702 psi)		
Gear oil volume	30 l (7.9 gal)		
Oil volume hydraulic motor	2 l (0.53 gal)		
Hydraulic connections (Drum cutter)			
Pressure / tank line	M42x2		
Leakage oil line	M30x2		
Hose lines (inside diameter)			
Pressure / tank line	19 mm (0.75 in.)		
Leakage oil line	19 mm (0.75 in.)		
Hole pattern (group)	9		

¹ Weight applies to standard carriers only. Any variations must be agreed with Construction Tools GmbH and / or the carrier manufacturer.

² Drum cutter including adapter plate of medium size. Please note that the working weight can be considerably higher, depending on the adapter plate.

³ Drum cutter including rotatable upper part. Accessory parts such as the adapter plate are not included.

Type	VC 2000-0	VC 2000-1	VC 2000-2	VC 2000-3
Carrier weight class ¹	20 - 40 t (44100 - 88200 lbs)			
Service weight ²	2050 kg (4520 lbs)			
Weight without adapter ³	1800 kg (3968 lbs)			
Dimensions				
Total length	1470 mm (57.87 in.)			
Total width of cutter drums	1020 mm (40.16 in.)			
Diameter of cutter drum (average)	720 mm (28.35 in.)			
Nominal power	120 kW (161 hp)			
Oil flow rate idling, max.	320 l/min (84.5 gal (US)/min)			
Oil flow rate, recommended at 200 bar (2900 psi)	205 l/min (54.2 gal (US)/min)	240 l/min (63.4 gal (US)/min)	260 l/min (68.7 gal (US)/min)	300 l/min (79.3 gal (US)/min)
Operating pressure, max.	350 bar (5075 psi)			
Rotational speed, recommended	75 rpm			
Pick speed	2.8 m/s (9.2 fps)			
Number of picks	60			
Pick shaft diameter	30 mm (1.18 in.)			
Maximum cutting force at 350 bar (5075 psi)	43.3 kN (9734 lbf)	48.6 kN (10926 lbf)	54.2 kN (12185 lbf)	65.0 kN (14613 lbf)
Maximum torque at 350 bar (5075 psi)	15.6 kNm (11506 ft lbs)	17.5 kNm (12907 ft lbs)	19.5 kNm (14382 ft lbs)	23.4 kNm (17259 ft lbs)
Maximum rock hardness	80 MPa (11603 psi)			
Gear oil volume	48 l (12.68 gal)			
Oil volume hydraulic motor	5 l (1.32 gal)			
Hydraulic connections (Drum cutter)				
Pressure / tank line	M42x2			
Leakage oil line	M30x2			
Hose lines (inside diameter)				
Pressure / tank line	25 mm (0.98 in.)			
Leakage oil line	19 mm (0.75 in.)			
Hole pattern (group)	9 + 10			

¹ Weight applies to standard carriers only. Any variations must be agreed with Construction Tools GmbH and / or the carrier manufacturer.

² Drum cutter including adapter plate of medium size. Please note that the working weight can be considerably higher, depending on the adapter plate.

³ Drum cutter including rotatable upper part. Accessory parts such as the adapter plate are not included.

Type	VC 3000-1	VC 3000-2	VC 3000-3
Carrier weight class ¹	35 - 55 t (77000 - 121000 lbs)		
Service weight ²	3200 kg (7000 lbs)		
Weight without adapter ³	2900 kg (6393 lbs)		
Dimensions			
Total length	1690 mm (66.5 in.)		
Total width of cutter drums	1160 mm (45.7 in.)		
Diameter of cutter drum	800 mm (31.5 in.)		
Nominal power	160 kW (214 hp)		
Oil flow rate idling, max.	410 l/min (108 gal (US)/min)		
Oil flow rate, recommended at 200 bar (2900 psi)	270 l/min (71 gal (US)/min)	310 l/min (82 gal (US)/min)	350 l/min (92.5 gal (US)/min)
Operating pressure, max.	350 bar (5075 psi)		
Rotational speed, recommended	75 rpm	70 rpm	65 rpm
Pick speed	3.1 m/s (10.2 fps)	2.9 m/s (9.5 fps)	2.7 m/s (8.8 fps)
Number of picks	72		
Pick shaft diameter	30 mm (1.18 in.)		
Maximum cutting force at 350 bar (5075 psi)	49.5 kN (11128 lbf)	61.8 kN (13893 lbf)	74.0 kN (16636 lbf)
Maximum torque at 350 bar (5075 psi)	19.8 kNm (14604 ft lbs)	24.7 kNm (18218 ft lbs)	29.7 kNm (21905 ft lbs)
Maximum rock hardness	100 Mpa (14500 psi)		
Gear oil volume	63 l (16.6 gal)		
Oil volume hydraulic motor	6 l (1.58 gal)		
Hydraulic connections (Drum cutter)			
Pressure / tank line	M42x2		
Leakage oil line	M30x2		
Hose lines (inside diameter)			
Pressure / tank line	25 mm (0.98 in.)		
Leakage oil line	19 mm (0.75 in.)		
Hole pattern (group)	10		

¹ Weight applies to standard carriers only. Any variations must be agreed with Construction Tools GmbH and / or the carrier manufacturer.

² Drum cutter including adapter plate of medium size. Please note that the working weight can be considerably higher, depending on the adapter plate.

³ Drum cutter including rotatable upper part. Accessory parts such as the adapter plate are not included.

13 Appendix

13.1 Hydraulic installation version 1 for hydraulic hammer

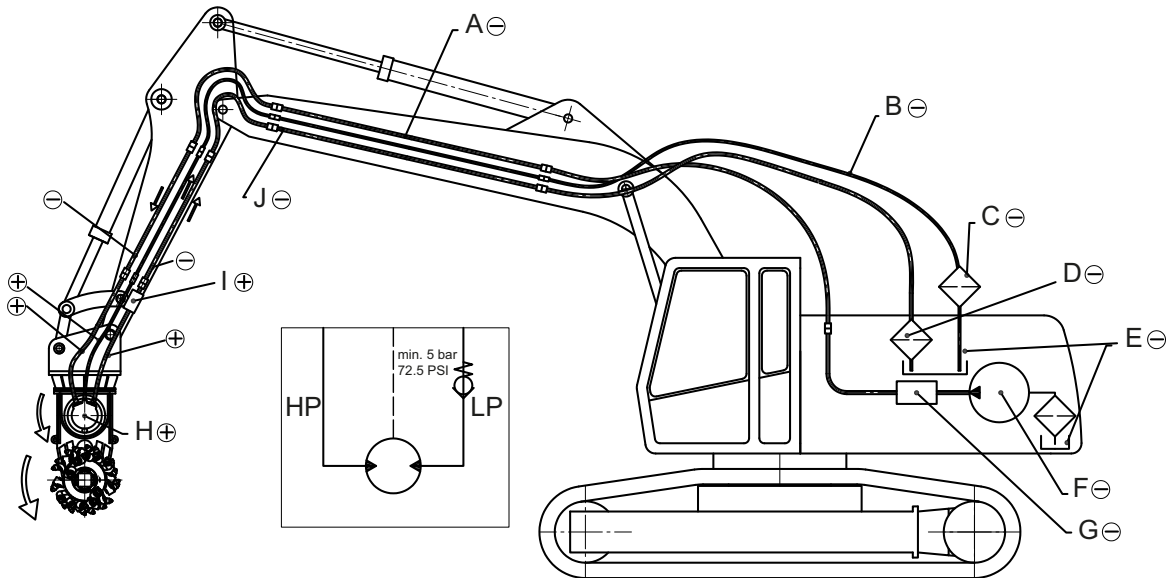

- Parts not included in the scope of delivery

+ Parts included in the scope of delivery

HP = high pressure, LP = low pressure

- A. Pressure line (High pressure HP) 350 bar (5075 psi) max., Q = X l/min (Y gal/min)
- B. Leakage oil line, Leakage oil pressure 3 bar (43.5 psi) max.
- C. Additional leakage oil filter
- D. Tank line filter
- E. Oil tank
- F. Oil pump
- G. Valve block
- H. Hydraulic motor
- I. Check valve 8 bar (116 psi)
- J. Tank line (Low pressure LP)

13.2 Hydraulic installation version 2 for hydraulic shear systems

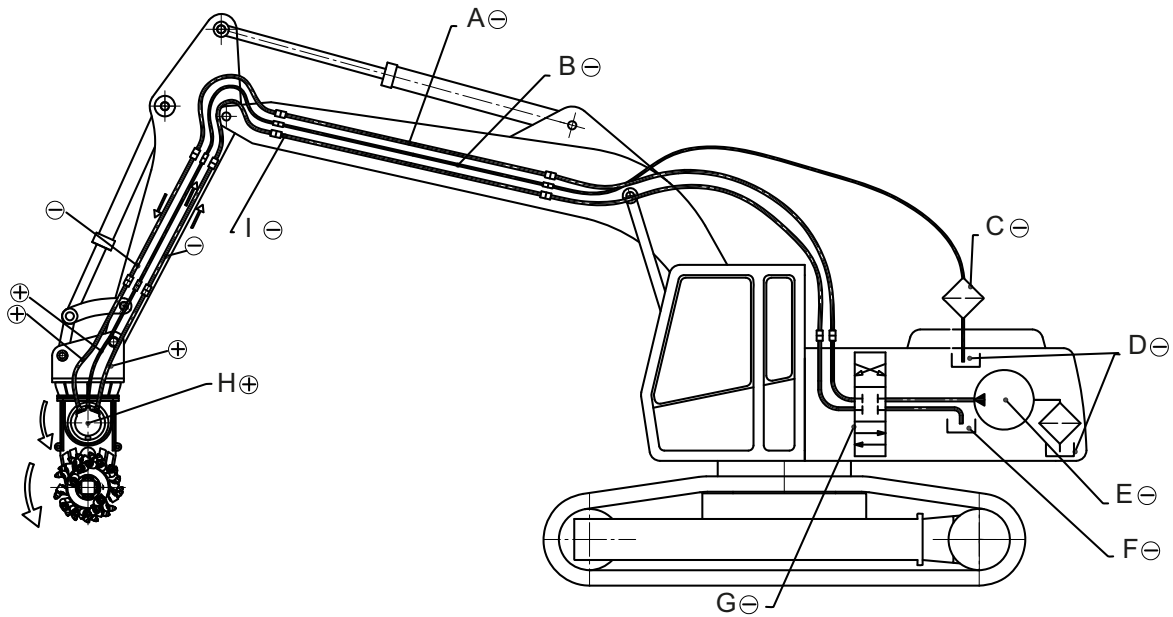

- Parts not included in the scope of delivery

+ Parts included in the scope of delivery

- A. Pressure line (High pressure HP) 350 bar (5075 psi) max., $Q = X \text{ l/min (Y gal/min)}$
- B. Leakage oil line, Leakage oil pressure 3 bar (43.5 psi) max.
- C. Additional leakage oil filter
- D. Oil tank
- E. Oil pump
- F. Tank
- G. Valve block
- H. Hydraulic motor
- I. Tank line (Low pressure LP) 15 bar (217.5 psi) min.

13.3 Hydraulic settings (explanation for following diagrams)

Q = Oil flow rate (l/min)

n = Cutter drum revolution (rpm)

p = Operating pressure (bar)

M = Torque at cutter drum (Nm)

P = Recommended operating setting (see technical data)

1 = Upper limit of the recommended power range:

The drum cutter must not be operated simultaneously at maximum operating pressure and maximum oil flow rate, otherwise the permissible nominal power is exceeded. The drum cutter must be operated within the recommended power range.

The higher the operating pressure the higher the cutting force and torque.

The higher the oil flow the higher the rotational speed and pick speed.

2 = maximum permissible motor load:

The combination of oil flow rate and operating pressure must not exceed the nominal power of the drum cutter.

The nominal power is checked according to the following formula:

Nominal power (kW) = $p \text{ (bar)} \times Q \text{ (l/min)} / 600$

13.4 Hydraulic settings VC 1400

VC 1400-1

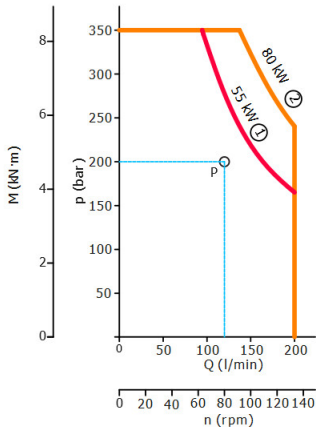

VC 1400-2

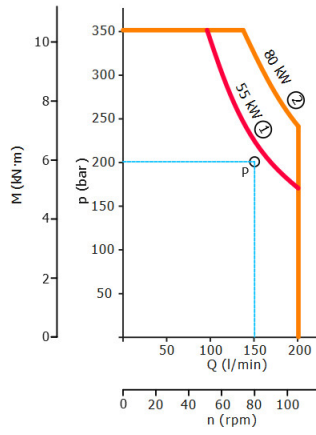

VC 1400-3

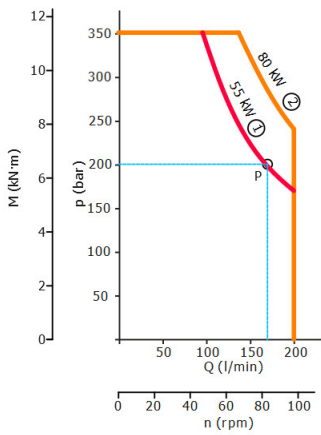

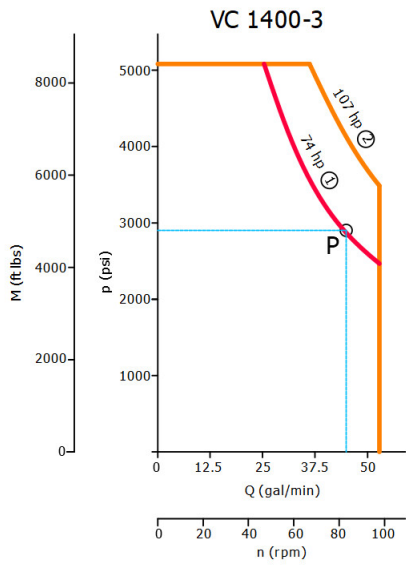
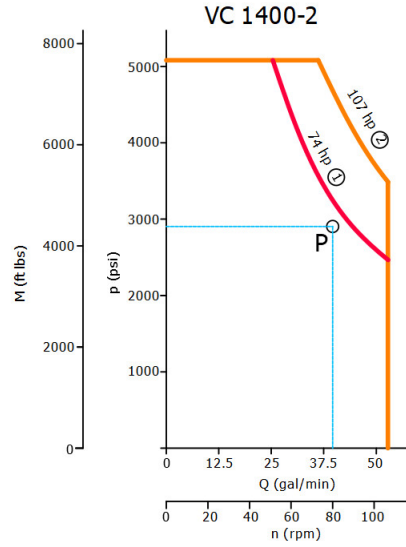
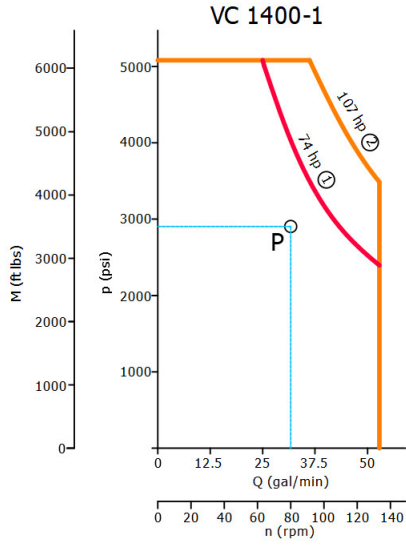

13.5 Hydraulic settings VC 2000

VC 2000-0

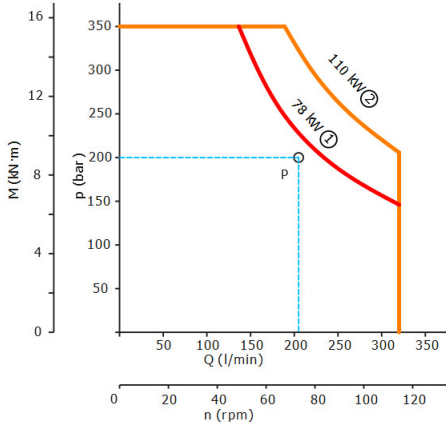

VC 2000-1

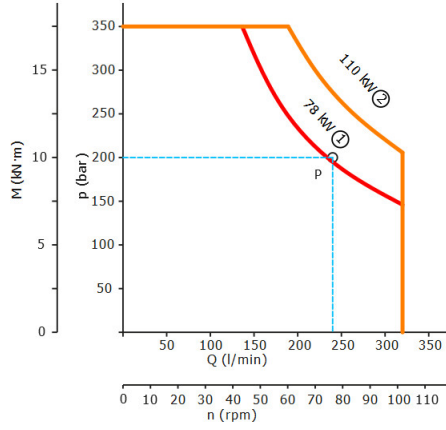

VC 2000-2

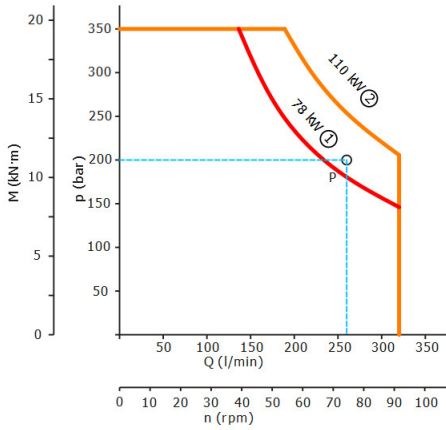

VC 2000-3

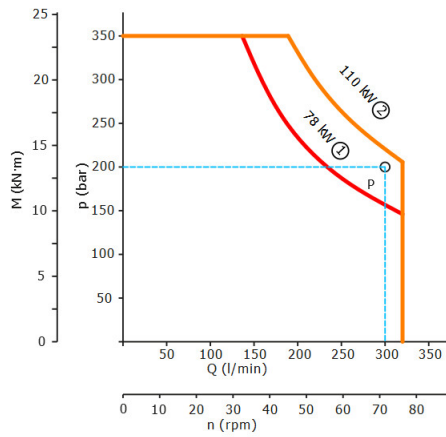

VC 2000-0

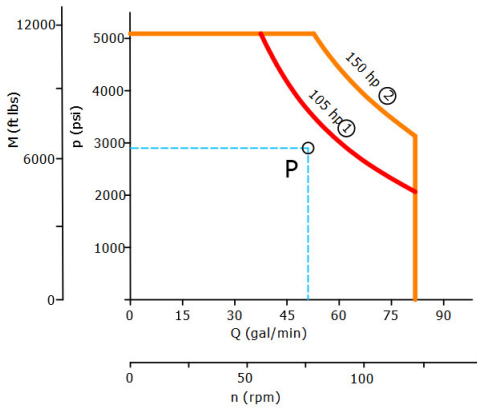

VC 2000-1

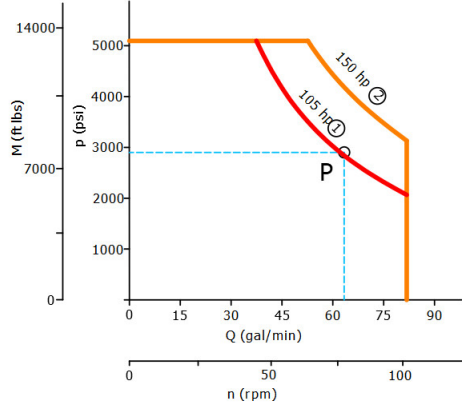

VC 2000-2

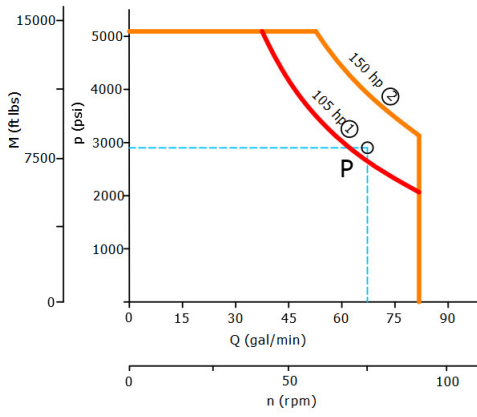

VC 2000-3

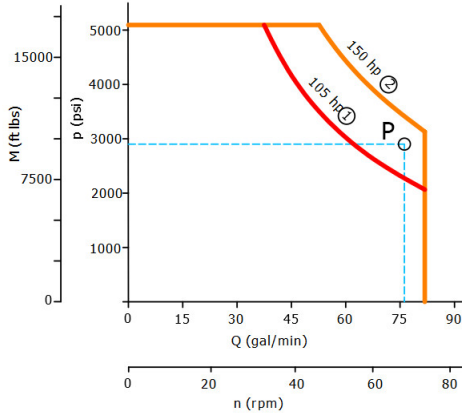

13.6 Hydraulic settings VC 3000

VC 3000-1

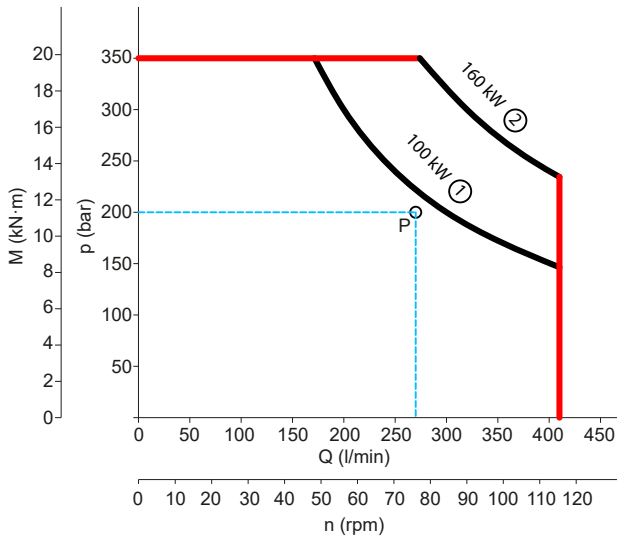

VC 3000-2

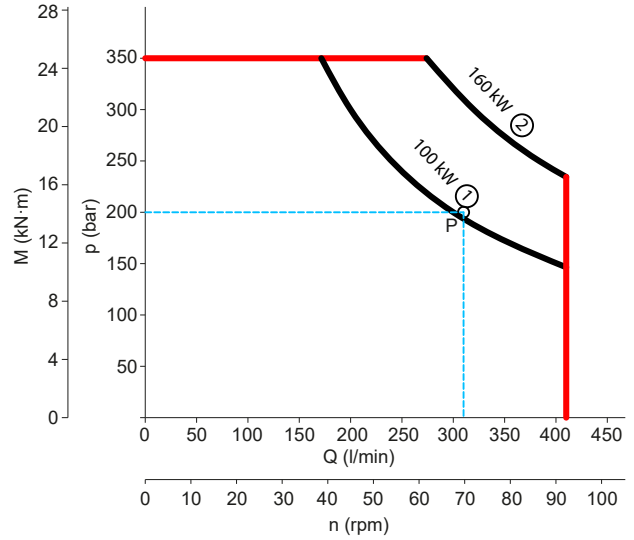

VC 3000-3

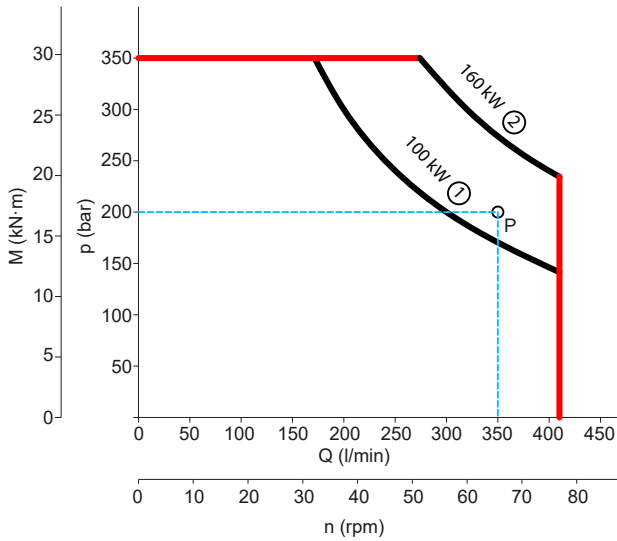

VC 3000-1

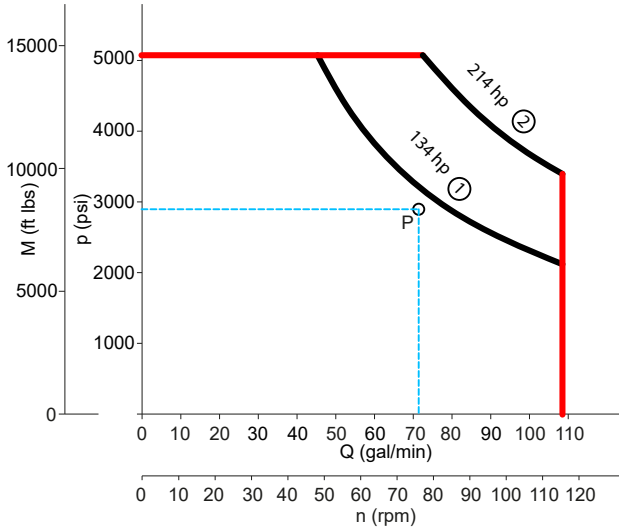

VC 3000-2

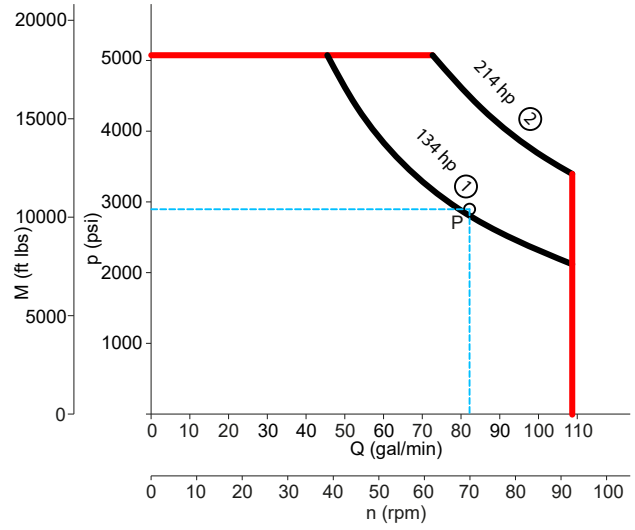

VC 3000-3

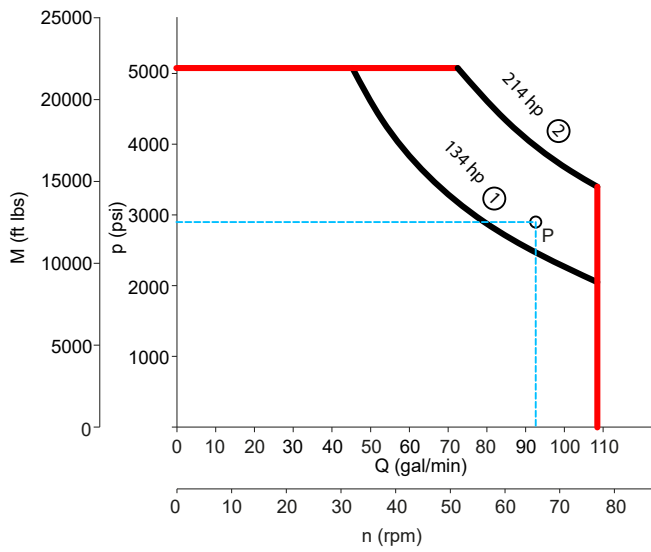

14 EC Declaration of Conformity (EC Directive 2006/42/EC)

We, Construction Tools GmbH, hereby declare that the machines listed below conform to the provisions of EC Directive 2006/42/EC (Machinery Directive) and the harmonised standards mentioned below.

Transverse drum cutter

VC 1400-1

VC 1400-2

VC 1400-3

VC 2000-0

VC 2000-1

VC 2000-2

VC 2000-3

VC 3000-1

VC 3000-2

VC 3000-3

Following harmonised standards were applied:

- EN ISO 12100
- EN 474-1

Technical Documentation authorised representative:

Roger Dähne

Construction Tools GmbH

Hämbacher Str. 5

36466 Dermbach OT Stadtlengsfeld, Germany

Authorised Representative:

see respective separate original EC declaration of conformity

Manufacturer:

Construction Tools GmbH

Hämbacher Str. 5

36466 Dermbach OT Stadtlengsfeld, Germany

Any unauthorized use or copying of the contents or any part thereof is prohibited. This applies in particular to trademarks, model denominations, part numbers, and drawings.

© Construction Tools GmbH | 3390 5248 01 | 2024-10-17