

Safety and operating instructions Hydro Magnets

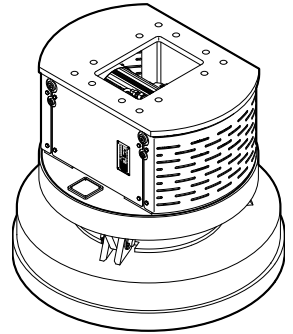

Table of Contents

1	Introduction	7
1.1	About these Safety and Operating Instructions	7
2	Safety instructions	8
2.1	Signal words	8
2.2	Qualification	9
2.3	Intended use	9
2.3.1	Generator system	10
2.4	Use other than intended	10
2.5	Protective equipment	11
2.6	Carrier, precautions	11
2.7	Transport, precautions	11
2.8	Magnetic field, precautions	12
2.9	Electrical shock, precautions	12
2.10	Explosion and fire, precautions	13
2.11	Hydraulic installation, precautions	13
2.12	Media/consumables, precautions	14
2.13	Handling machines, precautions	14
2.14	Repair, precautions	14
2.15	Changes to the hydraulic attachment, precautions	15
2.16	Environmental pollution, precautions	15
3	Overview	16
3.1	Equipment description	16
3.2	Function	18
3.3	Signs / labels	19
3.3.1	Name plate	19
3.3.2	Labels	19
3.4	Guarantee	20
3.5	Removing the packaging	20
3.6	Scope of delivery	20
4	Transport	21
4.1	Transport using a crane	21
4.2	Transport using a forklift truck	22
4.3	Transport using a truck	22
5	Installation	23
5.1	Media/consumables	23
5.1.1	Mineral hydraulic oil	23
5.1.2	Non-mineral hydraulic oil	23
5.2	Manufacturing the adapter plate	24
5.3	Installing the adapter plate	24
5.4	Attaching the hydraulic attachment to the carrier	25
5.4.1	Mechanical mounting aspects	25

5.4.2	First installation	25
5.4.3	Install separate leakage oil line	26
5.4.4	Making the hydraulic connections	26
5.4.5	Optional equipment	27
5.5	Removing the hydraulic attachment from the carrier	29
5.5.1	Dismantling the hydraulic connections	29
5.5.2	Mechanical disassembly	29
5.6	Removing the adapter plate.....	29
6	Operation	30
6.1	Making operational readiness	31
6.2	Switching the Hydro Magnet on and off	31
6.3	Functional test	32
6.4	Correct operation.....	33
6.4.1	Lift load.....	33
6.4.2	Drop load.....	33
6.5	Prohibited operation.....	34
6.5.1	Unsafe base	34
6.5.2	Non-load bearing suspended ceilings	34
6.5.3	Use over the chain	34
6.5.4	Moving the carrier.....	34
6.5.5	Impacting/chopping	35
6.5.6	Use under water	35
6.5.7	Cylinder end positions	35
7	Maintenance	36
7.1	Maintenance schedule	37
7.2	Depressurising the hydraulic system.....	38
7.3	Cleaning.....	38
7.4	Check wear ring of the magnet plate	38
7.5	Check the fixing of the magnet plate	38
7.6	Check chain (Version M)	38
7.7	Checking the connecting cable of the magnet plate	39
7.8	Checking bolted connections.....	39
7.9	Checking the hydraulic attachment and adapter plate for cracks	39
7.10	Checking the adapter plate bolts for wear	39
7.11	Checking hydraulic lines	39
7.12	Checking and cleaning the hydraulic oil filter of the carrier	39
7.13	Bolt connections / Tightening torques	41
8	Troubleshooting	42
8.1	Control centre fault - reset.....	42
8.2	LED 4 lights up: Interruption	42
8.3	LED 4 flashes: Interruption of the connection between the control center and the display.....	42
8.4	LED 5 lights up: Overload.....	42
8.5	LED 5 flashes: System failure	43
8.6	LED 6 lights up: Underspeed.....	43
8.7	LED 6 flashes: Overspeed	43
8.8	Relative duty cycle greater than or equal to 80 %.....	43

8.9	LEDs 4, 5 and 6 flash simultaneously: Insulation fault detected	43
8.10	LED 4, 5, 6 light up and 100 % flash: Pre-alarm over temperature of the control electronics	44
8.11	LED 4, 5, 6 and 100 % flash: Over temperature control electronics	44
8.12	No LEDs lights up even though the magnet plate is switched on	44
8.13	Magnet plate cannot be switched on	44
8.14	No LEDs lights up even though the magnet plate is switched on	45
8.15	Magnet plate cannot be switched on	45
8.16	Oil leaks from Hydro Magnet	45
9	Repair	46
9.1	Sending in the hydraulic attachment for repairs	46
10	Storage	47
11	Disposal	48
11.1	Hydro Magnet	48
11.2	Hydraulic hoses	48
11.3	Hydraulic oil	48
12	Technical specifications	49
13	EC Declaration of Conformity (EC Directive 2006/42/EC)	50

1 Introduction

Epiroc is a leading productivity partner for the mining, infrastructure and natural resources industries. With cutting-edge technology, Epiroc develops and produces innovative drill rigs, rock excavation and construction equipment, and provides world-class service and consumables.

The company was founded in Stockholm, Sweden, and has passionate people supporting and collaborating with customers in more than 150 countries.

Construction Tools GmbH

P.O. Box: 102152

Helenenstraße 149

D - 45021 Essen



Tel.: +49 201 633-0

1.1 About these Safety and Operating Instructions



The aim of these Instructions is to familiarise you with the safe and effective operation of the hydraulic attachment. You will also find instructions for regular maintenance activities for the hydraulic attachment in this document.

Please read these Instructions carefully prior to the first attachment and use of the hydraulic attachment.



The different designation of the texts means as follows:

	Action step in a safety instruction
	Action step
1. 2.	Established operation process
A B C	Explanation of the elements of a drawing
• • •	Listing

Symbols used in illustrations have the following meanings:

	permitted operation
	prohibited operation

2 Safety instructions

	This is the safety alert symbol. It is used to alert you to potential personal injury hazards. Obey all safety messages that follow this symbol to avoid possible injury or death.
	Read these Safety and operating instructions and specifically all safety instructions before using the hydraulic attachment. This will: <ul style="list-style-type: none"> • prevent the risk of injuries and fatal accidents for yourself and others, • protect the environment against environmental damage. • protect the hydraulic attachment and other property against material damage,

Follow all instructions in these Safety and operating instructions.

Store these Safety and operating instructions in the document compartment of the carrier cab.

Anyone

- transporting,
- installing or removing,
- operating,
- maintaining,
- repairing,
- storing or
- disposing of

the hydraulic attachment must have read and understood these Safety and operating instructions.

These Safety and operating instructions belong to the hydraulic attachment. Keep it for the life of the product. Ensure, if applicable, that any received amendment is incorporated in the instructions. Hand over the Safety and operating instructions if ever you lend, rent out or sell the hydraulic attachment.

All safety regulations listed in this manual comply with the laws and regulations of the European Union. Also observe the additional national/regional regulations.

Hydraulic attachment operation outside the European Union is subject to the laws and regulations valid in the country of use. Please observe any other, more stringent regional regulations and legislation.

Read the carrier manufacturer's Safety and operating Instructions before attaching the hydraulic attachment to the carrier and operating it. Observe all instructions.

2.1 Signal words

The signal words Danger, Warning, Caution, and Notice are used as follows in these Safety and operating instructions:

DANGER	indicates a hazardous situation which, if not avoided, will result in death or serious injury.
WARNING	indicates a hazardous situation which, if not avoided, could result in death or serious injury.
CAUTION	indicates a hazardous situation which, if not avoided, could result in minor or moderate injury.
NOTICE	The signal word NOTICE is used to address practices related to possible property damage but not related to personal injury.

2.2 Qualification

Transporting the hydraulic attachment is only permitted if carried out by people who:

- are authorised to operate a crane or a forklift truck according to the applicable national provisions,
- know all the relevant national/regional safety provisions and accident prevention rules,
- have read and understood the safety and transport chapter of these Safety and operating instructions.

Installing, maintaining, storing and disposing of the hydraulic attachment are only permitted if carried out by people who:

- know all the relevant national/regional safety provisions and accident prevention rules,
- have read and understood these Safety and operating instructions.

Operating the hydraulic attachment is only permitted if carried out by qualified carrier drivers. Carrier drivers are qualified if they:

- have been trained to operate a carrier according to the national regulations,
- know all the relevant national/regional safety provisions and accident prevention rules,
- have read and understood these Safety and operating instructions.

Testing the hydraulic installation is only permitted if carried out by professionals. Professionals are people who are authorised to approve a hydraulic installation for operation according to the national regulations.

Repairing the hydraulic attachment is only permitted if carried out by professionals trained by Construction Tools GmbH. These professionals must have read and understood these Safety and operating instructions. They must follow all safety instructions and guidelines for repair. Otherwise the operational safety of the hydraulic attachment is not guaranteed.

2.3 Intended use

You may only use the Hydro Magnet for collecting and separating ferro-magnetic materials.

Only attach the Hydro Magnet to a hydraulic carrier of a suitable load-bearing capacity. Read the carrier manufacturer's Safety and Operating instructions before attaching the Hydro Magnet to the carrier and operating it. Observe all instructions.

Select the carrier and the lifting equipment so that they are designed to handle the Hydro Magnet with its maximum recommended load.

You must connect the Hydro Magnet to the carrier via an adapter plate or a quick coupler. The suitability of the adapter plate or the quick coupler must be considered in the light of the maximum load.

The Hydro Magnet may only be operated when no person is in the danger zone of 20 meters (66 ft) around the Hydro Magnet. The danger zone of the Hydro Magnet must be secured with a construction fence (height 2 m (6.6 ft)).

You may operate the Hydro Magnet at an ambient temperature of - 10 °C to + 50 °C (14 °F to 122 °F).

Permitted Loads:

The loads must be ferro-magnetic. To determine the load capacity of the magnet, a flat piece of low-carbon iron and a predetermined air gap was used. For materials that consist of more solid iron that are coated and thus have a higher carbon content, the load capacity is reduced.

Reduce your values by the relevant factor in the following table:

0.9	for molten iron
0.8	for iron with 3% silicon
0.7	for iron type C60
0.45	for cast iron

The loads:

- shall be of such a form and dimension that an absolute contact is guaranteed on the magnetic surface.
- must have a clean and flat surface so that no greater air gap than that expected occurs.
- must not change their static condition during transport, eg, thin and long loads must not bend.

If the Hydro Magnet is used for lifting of scrap, the scrap weight plus the weight of the Hydro Magnet must not exceed the load capacity of the lifting equipment used (ropes, chains, shackles, etc.), or the adapter plate or quick coupler.

2.3.1 Generator system

The generator system described in this manual is a modular energy-generating system for Hydro Magnets. The generator system is intended for use as fixed mounted power generator.

- The generator system is to be used exclusively for the magnet plate of Hydro Magnets of the HM series.
- Only use the generator system in accordance with the voltage and power specifications on the nameplate.
- Drive the generator system with the specified nominal speed.
- Use the generator system only for the purposes specified in these Safety and Operating instructions. Any other use is improper and not permitted.

Installation and commissioning of the Hydro Magnet may only be carried out by qualified personnel who are authorized to commission, ground and label devices, systems and circuits in accordance with the standards of safety technology.

2.4 Use other than intended

Incorrect, inappropriate use and lack of maintenance can cause dangerous situations. Injury or damage may result.

Never use the Hydro Magnet:

- for transport or lifting of persons.
- if there are people in the work area.
- when people stand or work under suspended loads.

Both persons and raised objects can fall/be dropped.

Both can lead to serious injury or death.

- Never start demagnetization before the load is on the ground or hovering just above the discharge point.

A falling object can result in serious injury or death.

- Prevent the use of the Hydro Magnet by people who are:

- unqualified or
- in poor health.

Uncontrolled, improper use can result in serious injury or death.

- Never use the Hydro Magnet in an environment containing acid gases or abrasive powder.

Cables and connectors may be damaged and cause insulation damage.

Never use the Hydro Magnet:

- under water.
- in towing or pushing operations.

The Hydro Magnet is not designed for this operation.

Unallowed Loads:

- Loads exceeding the specified load capacity.
- Loads that are almost at the load limit capacity but do not cover the entire magnetic surface.
- Loads that are dirty and could therefore have a larger air gap.
- Loads with a temperature considerably higher than the ambient temperature.

2.5 Protective equipment

Personal protective equipment must comply with the applicable health and safety regulations.

Always wear the following personal protective equipment:

- protective helmet
- safety glasses with side protectors
- protective gloves
- protective shoes
- warning vest

2.6 Carrier, precautions

▲ WARNING Falling carrier

If the load-bearing capacity of the carrier used is insufficient, the carrier will not be stable. It can topple over and cause injuries and damage.

- ▶ Only attach the hydraulic attachment to a hydraulic carrier of a suitable load-bearing capacity.
- ▶ The carrier must remain stable at all times, even when the Hydro Magnet has lifted its maximum load.
- ▶ Read the carrier manufacturer's Safety and Operating Instructions before attaching the hydraulic attachment to the carrier and operating it. Observe all instructions.

2.7 Transport, precautions

▲ WARNING Risk of death due to suspended loads

When lifting loads these can swivel and fall off. This can result in serious injuries or even death.

- ▶ Shut off the danger zone in a radius of 20 m around the Hydro Magnet with a construction fence.
- ▶ Never stand underneath or in the swivelling range of the Hydro Magnet.
- ▶ When operating the Hydro Magnet, ensure that you always have a clear view of the load. Let an assistant instruct you, if this is not possible. The assistant must be located outside the danger zone.
- ▶ When leaving the workplace, lower the Hydro Magnet to the floor/ground.

▲ WARNING Risk of death due to loads crashing down

A loss of drive power always leads to uncontrolled discharge of suspended loads on the magnet plate. Falling loads can cause serious injury or even death.

- ▶ Check prior to commissioning that sufficient drive power is provided and check the reliability of the drive.
- ▶ Put the Hydro Magnet immediately on solid ground from when problems in the drive power occur.
- ▶ Do not operate the Hydro magnet before operational safety of the drive and sufficient drive power are ensured.
- ▶ Switch on the magnet plate only then, when it is needed to work.

▲ WARNING Injury due to swivelling load

When transporting the load by crane it can swivel and cause severe injuries and considerable damage to property.

- ▶ Ensure that no personnel, objects or obstacles are located in the swivel range of the load.

2.8 Magnetic field, precautions

▲ **WARNING Risk of magnetic field**

The electromagnetic field can cause interference and damage to electronic devices (such as cardiac pacemakers). It can also move ferro-magnetic objects inadvertently. This can lead to serious injury or even death.

- ▶ Persons with cardiac pacemakers must keep a safe distance of at least 2 m from the Hydro Magnet.
- ▶ Persons with metal prostheses must keep a safe distance of at least 2 m from the Hydro Magnet.
- ▶ No person may bear or carry ferro-magnetic objects in the field of Hydro Magnet, since it will exert an attracting force and could cause bruising or injury.
- ▶ Keep a safe distance of at least 2 m from the Hydro Magnet with electronic devices such as computers, monitors, credit cards, mobile phones, magnetic cards, etc..
- ▶ Secure a spacious working area for the Hydro Magnet with warning signs, to alert personnel and others to the dangers of the magnetic field.

2.9 Electrical shock, precautions

▲ **DANGER Danger to life through electrical voltage**

During operation, dangerous voltages may occur. This can lead to serious injury or even death.

- ▶ Maintenance and repair work on the Hydro Magnet may be carried out only in the off and de-energized state.
- ▶ Turn off the carrier and secure it against unintentional start, for example by removing the ignition key and store.
- ▶ Never open the housing of the Hydro Magnet during operation.
- ▶ Never loose or connect any cables during operation.
- ▶ Never hold the beam of a high-pressure cleaner on the Hydro Magnet. There is a danger of electric shock and danger of destruction.

▲ **DANGER Danger to life through electrical voltage**

In case of an insulation fault the otherwise systemic present protection "electrical separation" is no longer effective. When another error arises lethal contact voltage can occur on metal parts. There may be sporadic or sudden load shedding and uncontrollable drop of lifted material. Insulation monitors can influence each other.

- ▶ Never operate the Hydro Magnet with an insulation fault.
- ▶ Do not install a further insulation monitor behind the generator system.

▲ **DANGER Danger to life through electrical voltage**

There may exist dangerous voltages up to max. 45 seconds in and close to the system after switching off the carrier.

- ▶ Only touch the Hydro Magnet when the voltages are degraded.

2.10 Explosion and fire, precautions

▲ DANGER Explosion and fire

Operating the Hydro Magnet may ignite highly flammable gases. This may lead to fire or an explosion.

- ▶ Never work in an environment with highly flammable substances.
- ▶ Make sure that there are no hidden sources of gas in the work area.

▲ DANGER Explosion and fire

Dust-rich air can form an explosive atmosphere which may ignite when operating the Hydro Magnet. This may lead to fire or an explosion.

- ▶ Never use the Hydro Magnet in an explosive atmosphere.
- ▶ Always provide sufficient ventilation when working in buildings or in a confined area.

2.11 Hydraulic installation, precautions

▲ WARNING Hydraulic pressure too high

If the hydraulic pressure is too high, the parts of the hydraulic attachment will be exposed to excessively high loads. Parts can break loose or burst causing serious injuries.

- ▶ Lay the drain line of the pressure relief valve directly in the tank to ensure the safe functioning of the pressure relief valve!
- ▶ The pressure relief valve must be set at the maximum static pressure.
- ▶ The pressure relief valve setting must be checked to ensure that the maximum static pressure (see chapter **Technical specifications**) of the hydraulic installation is not exceeded at any time. Attach a lead seal to the pressure relief valve.
- ▶ Prior to their first use, the safety facilities on the hydraulic installation must be checked by a professional/authorised monitoring body for their quality (CE mark etc.), suitability and proper functioning.
- ▶ If any significant changes are made to the hydraulic installation, a new acceptance inspection is to be carried out in accordance with the relevant national safety provisions.

▲ WARNING Hot hydraulic oil squirting out

The hydraulic system is under high pressure. Hydraulic lines may spring a leak or burst. Hydraulic oil squirting out can lead to serious injury.

- ▶ When attaching the hydraulic attachment do not route any hydraulic lines through the carrier's cab.
- ▶ Only use hydraulic lines which comply with the following quality requirements:
 - For the function generator on/off
 - Hydraulic hoses with 4 reinforcement steel wires according to DIN EN 856 4SH,
 - Hydraulic pipes, seamless cold-drawn steel pipes according to DIN EN 10305
 - For the function magnet plate on/off
 - Hydraulic hoses with 2 steel plaitings according to DIN EN 853 2SN,
 - Hydraulic pipes, seamless cold-drawn steel pipes according to DIN EN 10305.

2.12 Media/consumables, precautions

▲ **WARNING Hot hydraulic oil under high pressure**

Hydraulic oil will squirt out under high pressure if there is a leakage. The jet of oil might penetrate people's skin and cause permanent damage. Hot hydraulic oil can cause burns.

- ▶ Never use your hands to find leaks.
- ▶ Always keep your face away from a possible leak.
- ▶ If hydraulic oil has penetrated your skin consult a doctor immediately.

▲ **WARNING Hydraulic oil spills**

Spilt hydraulic oil can make a floor slippery. If people slip they can be injured. Hydraulic oil is environmentally harmful and must not penetrate the ground or enter the water table or water supplies.

- ▶ Make sure not to spill any hydraulic oil.
- ▶ Immediately clean the floor if you have spilt hydraulic oil.
- ▶ Observe all safety and environmental protection provisions when handling hydraulic oil.

▲ **WARNING Skin infections/diseases due to oil and grease**

Hydraulic oil and grease can cause rashes (or even eczema) if they come into contact with the skin.

- ▶ Avoid all skin contact with hydraulic oil and grease.
- ▶ Use a suitable skin protection product.
- ▶ Always wear safety gloves when working with hydraulic oil or grease.
- ▶ Immediately clean any skin that has been contaminated by oil or grease with water and soap.

2.13 Handling machines, precautions

▲ **WARNING Narcotics, alcohol and drugs**

Narcotics, alcohol and medicinal drugs make their users less alert and affect their ability to concentrate. Negligence and incorrectly assessing a situation can result in serious injury or death.

- ▶ Never work on or with the hydraulic attachment when under the influence of narcotics, alcohol or drugs which affect your alertness.
- ▶ Never allow other people who are under the influence of narcotics, alcohol or drugs which affect their alertness to work on or with the hydraulic attachment.

2.14 Repair, precautions

▲ **WARNING Risk of injury**

Non-professional repair of the Hydro Magnet may lead to serious injury and property damage.

- ▶ Repair is only permitted if carried out by professionals trained by Construction Tools GmbH. These professionals must follow all safety instructions and guidelines for repair.
- ▶ Consult the Epiroc Customer Center / Dealer in your area.

2.15 Changes to the hydraulic attachment, precautions

▲ **WARNING** Changes to the hydraulic attachment

Changes to the hydraulic attachment or the adapter plate may lead to serious injury.

- ▶ Never carry out any changes to the hydraulic attachment or the adapter plate.
- ▶ Only use original parts or accessories approved by Epiroc.
- ▶ Modifications that entail new hazards may require a new procedure for assessing conformity.

2.16 Environmental pollution, precautions

NOTICE Environmental pollution due to hydraulic oil

Hydraulic oil is permanently environmentally harmful. Escaped hydraulic oil will lead to groundwater and soil contamination. Organisms may die.

- ▶ Collect any hydraulic oil which escapes to avoid environmental pollution. For minor volumes use an absorbing medium (in case of an emergency use soil). In case of major leakages contain the hydraulic oil. It must not drain off and penetrate the ground or enter the water table or water supplies.
- ▶ Collect contaminated absorbing medium or soil in a watertight box/container and close it tight.
- ▶ Contact an authorized waste management company.
- ▶ Dispose of all contaminated material in accordance with the applicable environmental regulations.

3 Overview

3.1 Equipment description

The picture gives an overview of the main parts and components of the hydraulic attachment. Actual details may differ.

Version F

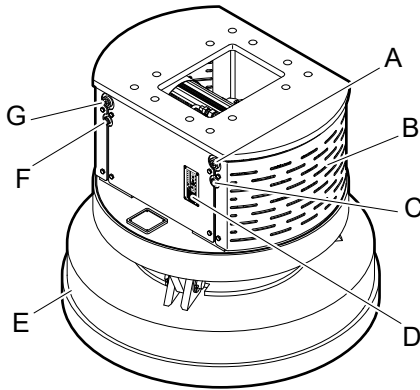

HM Version M

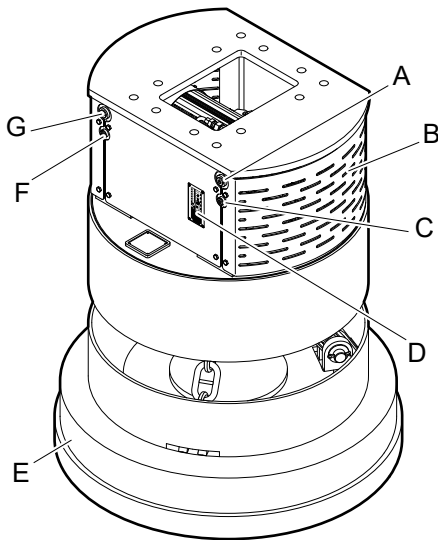



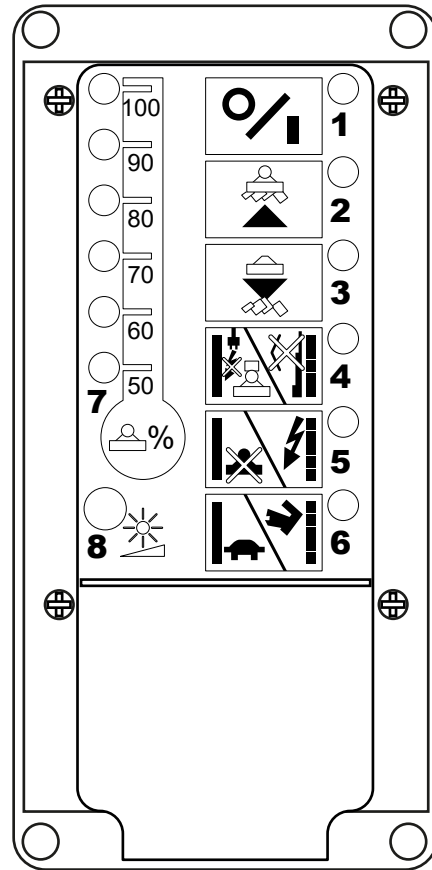

- A. Tank line »T«
- B. Cooling air openings
- C. Leak oil line (not required in all case)
- D. Display
- E. Magnet plate
- F. Control line
- G. Pressure line »P«

Display

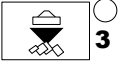

1. Electric power available
2. Magnet plate on „Lift load“
3. Fast demagnetization activated „Drop load“
4. Interruption / Error
5. Overload / System failure
6. Underspeed / Overspeed
7. Relative duty cycle of magnet plate
8. Light sensor

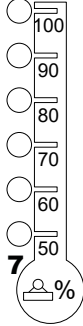

<p>LED 1</p>	<p>Green operation indicator</p> <hr/> <p>Power supply voltage available. The system is switched on and ready for operation. LED lights up when the generator is running and supplies voltage.</p>
<p>LED 2</p>	<p>Yellow operation indicator</p> <hr/> <p>Magnet plate switched on. „Lifting“. LED lights up as long as the magnet plate remains switched on. LED flashes if magnetized in safety operations (slab handling first with reduced pulling force) is being worked on. As soon as the max. Traction power has been requested lights up the LED permanently.</p>

	<p>Note: If the LED lights after switching on for about 1-2 seconds and then switches off again, or if LED 4 lights up, the connection cable of the magnet plate is not plugged in or interrupted.</p>		<p>Note: Overload limiter active is a warning. This message is displayed only for significant overload (> 110%). However, when shown, the suitability of the magnet plate for the system should be checked.</p>
<p>LED 3</p> 	<p>Yellow operation indicator</p> <p>Quick demagnetization enabled. "Dropping".</p> <p>LED lights up during the quick demagnetization.</p> <p>LED goes out when the quick demagnetization is complete.</p> <p>LED also goes out when the quick demagnetization is cancelled.</p> <p>LED flashes when (advanced sorting) has been requested by the operator, a slow drop and thus decreases the material very slowly and controlled.</p> <p>Note: The magnet plate may for some time have a remanent magnetism because the demagnetization proceeds much more slowly.</p>		<p>LED flashes:</p> <p>System failure: A safety-critical error has occurred. The output to the magnet plate is switched off immediately.</p> <p>LED goes out after a system restart.</p> <p>Note: For error localization error blink code can be read for generator systems. Consult the Epiroc Customer Center / dealer in your area.</p>
<p>LED 4</p> 	<p>Red error indicator</p> <p>Interruption / Error</p> <p>LED lights up:</p> <p>Interruption: The magnet plate connection cable is not plugged in or has been interrupted. After switching on, the system checks whether a current flows to the magnet plate. If no current is flowing (Interruption), the magnet plate is automatically switched off for security reasons after about 1-2 seconds, and the LED lights up.</p> <p>LED goes out when the fault no longer exists after the next restart.</p> <p>LED flashes:</p> <p>Error: Error occurring in the connection between control center and display. The display no longer responds.</p>	<p>LED 6</p> 	<p>Red error indicator</p> <p>Underspeed / Overspeed</p> <p>LED lights up:</p> <p>Underspeed: The LED lights up to indicate that the generator is running at underspeed. The magnet plate is switched off automatically.</p> <p>LED goes out when the rotation speed is back within the tolerance limits.</p> <p>Note: At very low rotation speeds, it is for security reasons no longer possible to switch on the Hydro Magnet.</p> <p>LED flashes:</p> <p>Overspeed: The generator is running at overspeed. After dropping the load, no switching on again is possible.</p> <p>LED goes out when the rotation speed is back within the tolerance limits.</p> <p>Note: Too high rotation speeds can also lead to system failure with diagnosis: Overvoltage fault (error code: 10).</p>
<p>LED 5</p> 	<p>Red error indicator</p> <p>Overload / System failure</p> <p>LED lights up:</p> <p>Overload: The attached magnet plate is too large for the system. The built-in overload and fault current limiter of the system is active. The LED remains on after restart.</p> <p>LED does not go out until after the next magnet plate switch on without detection of an overload.</p> <p>This error does not result in an automatic shutdown of the magnet plate.</p>	<p>LED 7</p> 	<p>Multi-coloured operation indicator</p> <p>(50 % green, 60 % and 70 % yellow, from 80 % red):</p> <p>Relative duty cycle greater than or equal to 80 % The relative duty cycle of the magnet plate is the ratio between between on-period and off-period. An on-period of 1 minute and a following off-period of 1 minute, for example, correspond to a relative duty cycle of 50 %. In normal operation, the relative duty cycle should be between 50 % and 70 %.</p> <p>With a relative duty cycle of 80 %, there is a risk that the magnet plate overheats. To protect the magnet plate, reduce the on-period of the magnet plate until the display is back to the normal range between 50 % and 70 %.</p>

 8	Light sensor Auto brightness control To ensure that the display is always easy to read, the brightness of the LEDs is automatically adjusted with the help of this sensor. The LEDs light, for example, brighter in sunlight than in low light conditions.
--	--

takes the temperature of the control electronics to fall below the warning temperature.

Note: Newer systems report a temperature overshoot as system failure (LED 5 flashes). In newer systems, the control electronics will not shut off the magnets for safety reasons. However, this message **MUST ALWAYS** be considered the most critical operating point!

LED 4  LED 5  LED 6 	LEDs 4, 5 and 6 flash simultaneously Insulation fault detected If an insulation fault is detected, a restart is automatically blocked. The Hydro Magnet cannot be switched on again. This is a safety risk! Lethal contact voltages can occur on metal parts! Contact a qualified electrician immediately.
--	--

3.2 Function

The operation of a Hydro Magnet is described in a greatly simplified version below:

The pressure line »P« supplies oil at the operating pressure of the carrier to the generator of the Hydro Magnet. The tank line »T« returns the oil to the tank of the carrier.

The generator generates the energy for the Hydro Magnet. The control electronics are attached to the generator. This is connected with the display.

The Hydro Magnet is operated by a manual or foot control in the driver's cab of the carrier. The operating conditions of the system are controlled on the display.



Lift load (switch-on magnet plate)

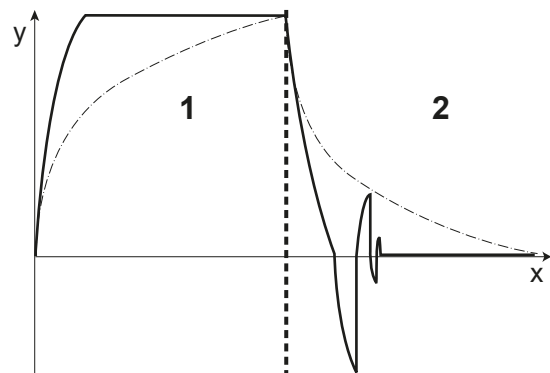

After switching on, the generator outputs a voltage for magnetizing the magnet plate. When you first switch on after the start of the system, the current flowing in the magnet plate increases relatively slowly until the rated current is reached. The nominal voltage at the magnet plate is then about 230 V.

This process is illustrated in the following drawing as a dashed curve.



1	Magnetization
2	Demagnetization
x	Time
y	Magnetic tractive force

LED 4  LED 5  LED 6 	LEDs 4, 5 and 6 light up simultaneously and 100 % flashes Pre-alarm over temperature of the control electronics Although the generator system is designed for continuous operation, it may be too hot in some special cases. This risk exists when at full load, if the cooling of the generator and the control electronics is disabled or if the temperature of the cooling air exceeds the maximum allowable value of 40 °C (104 °F). Warning temperature of control electronics The temperature in the control electronics, has exceeded the pre-alarm limit value. The generator system is blocked from restarting until the temperature has decreased in the control electronics again and overtemperature - advance warning goes out. If the generator system is still used despite an overtemperature - advance warning under load, the temperature will continue to rise, and after about 10 minutes an immediate shutdown of the system will occur due to exceeded temperature limit.
--	--

LED 4  LED 5  LED 6 	LEDs 4, 5 and 6 and 100 % flash Temperature exceeded control electronics The temperature in the control electronics has exceeded the allowed limit, and the system is switched off immediately without warning. Lifted loads may be dropped from the magnet plate. After the automatic shutdown of the system, a lock-prevention prohibits switching on the magnet plate again as long as it
--	--

In this graph it can be seen that it takes a relatively long time for the magnet plate to reach its maximum magnetic tractive force to lift a load. To speed up this relatively slow magnetization, the Hydro Magnet uses a quick impulse excitation method for all the following magnetization processes. The quick magnetization with impulse excitation is shown in the figure as a black curve.

Drop load (switch-off magnet plate)

Conventional demagnetization functions at a similarly slow rate as the magnetization without impulse excitation. Due to the long-lasting residual magnetism of the magnet plate, it requires a relatively long time to drop all of the load.

This process is illustrated in the above drawing as a dashed curve. To speed up the demagnetization, the Hydro Magnet uses an automatic demagnetization with reverse voltage and ensuing pulsation, shown in the drawing as a black curve.

3.3 Signs / labels

▲ WARNING Missing warnings

The name plate and the labels on the hydraulic attachment contain important information about the hydraulic attachment and for personal safety. A missing warning can lead to overlooking or misinterpretation of possible risks and cause personal hazards. The signs and labels must always be clearly legible.

- ▶ Immediately replace any defective name plates and labels.
- ▶ Consult your local customer center/dealer.



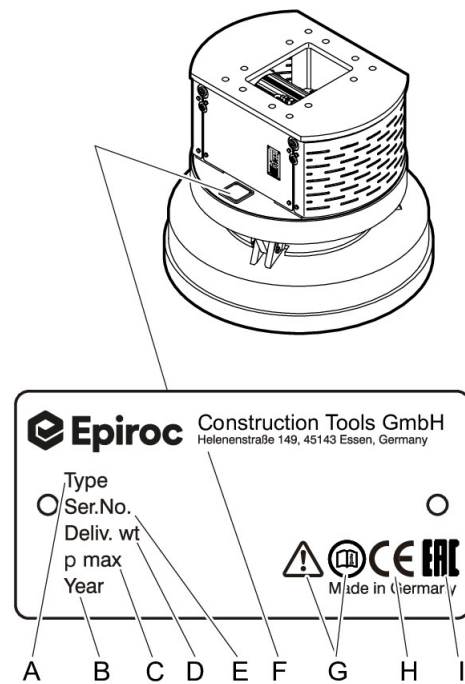



3.3.1 Name plate



- A. Model
- B. Year of construction of hydraulic attachment
- C. Max. permissible operating pressure
- D. Weight of hydraulic attachment
- E. Serial number
- F. Name and address of manufacturer
- G. The warning symbol and the book symbol indicate that the Safety and Operating Instructions must be read prior to use of the hydraulic tool and in particular the chapter on Safety.
- H. The CE symbol indicates that the hydraulic attachment was produced in conformity with CE. You can find further information about this in the enclosed EC Declaration of Conformity.
- I. The EAC symbol means that the machine is EAC approved.

3.3.2 Labels

	Warning for explosion
--	-----------------------

	Warning for hot surface
	Warning for hazardous electrical voltage
	Warning for non-ionizing electromagnetic radiation
	Warning of suspended load
	Warning of magnetic field
	Warning to persons with cardiac pacemakers
	The warning symbol and the book symbol indicate that the Safety and Operating Instructions must be read prior to use of the hydraulic attachment and in particular the chapter on Safety.

- Changes not carried out by or in consultation with the manufacturer

3.5 Removing the packaging

- Remove all the packaging material.
- Dispose of it in accordance with the applicable provisions.
- Check that the delivery is complete.
- Check the delivery for visual damage.
- If any defects are found, consult the Epiroc Customer Center / dealer in your area.

3.6 Scope of delivery

The Hydro Magnet is delivered complete with:

- Hydro Magnet
- Safety and operating instructions
- EC Declaration of Conformity

Accessories as ordered:

- Hoses

Special accessories as ordered:

- e.g. adapter plate with Allen screws and pairs of lock washers
- e.g. base plate to construct an adapter plate with Allen screws and pairs of lock washers
- e.g. hydraulic fittings for the carrier
- e.g. Joystick activation kit

3.4 Guarantee

The guarantee or product liability will be invalidated by the following:

- Use other than intended
- Maintenance work not being carried out or being carried out incorrectly
- The use of incorrect consumables
- The use of non-approved parts
- Damage due to wear
- Damage due to improper storage

4 Transport

▲ **WARNING** Hoist tipping over / hydraulic attachment falling

The hydraulic attachment is heavy. The hoist/lifting equipment and/or hydraulic attachment tipping over or falling may cause serious injury and material damage.

- ▶ Only transport the hydraulic attachment with lifting equipment with the right load-bearing capacity for the weight of the hydraulic attachment.
- ▶ Only lift and secure the hydraulic attachment with lifting gear (ropes, chains, shackles etc.) with the right load-bearing capacity for the weight to be lifted.
- ▶ Make sure that there is nobody near or under the suspended hydraulic attachment.
- For transporting use four adjustable eyebolts with washer and nut (3363 1067 08) as lifting lugs. Standard eyebolts (DIN 580) are not permissible.

4.1 Transport using a crane

- Insert the four adjustable eyebolts from above into the four holes (see figure) in the top plate.
- Slide one washer on each screw thread and screw the nuts on.
- Tighten the nuts.
- Attach ropes or chains to the adjustable eyebolts as shown in the following illustration.

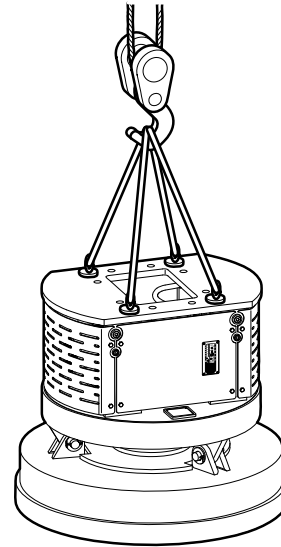

- Slowly lift the Hydro Magnet.
- Place the Hydro Magnet on level ground.
- Turn the nuts from the adjustable eyebolts.
- Remove the washers from the screw threads and the adjustable eyebolts from the top plate.
- Store the adjustable eyebolts, washers and nuts in a safe place.

4.2 Transport using a forklift truck

▲ WARNING Hydraulic attachment tipping over

The hydraulic attachment tipping off the fork of the forklift truck or the pallet may cause serious injury.

- ▶ Place the hydraulic attachment on a pallet.
- ▶ Strap the hydraulic attachment to the pallet using suitable strapping, as shown in the illustration below.
- ▶ Move the fork of the forklift truck under the pallet so that the centre of gravity is between the prongs.

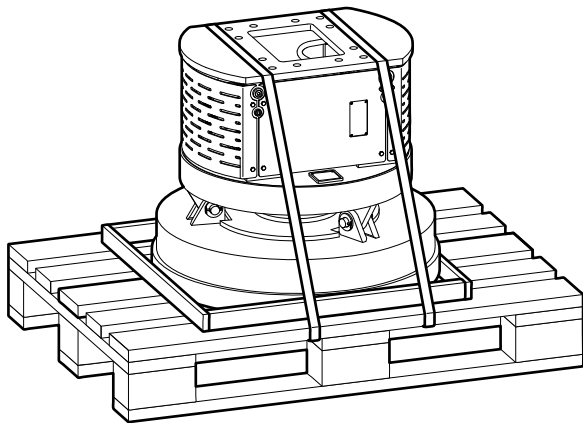

- Move the fork of the forklift truck under the pallet so that the hydraulic attachment cannot tip over.

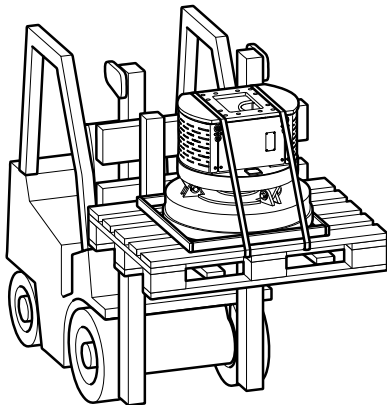

- Slowly lift the pallet with the hydraulic attachment.
- Transport the pallet with the hydraulic attachment to the location provided for.

4.3 Transport using a truck

▲ WARNING Hydraulic attachment tipping over / slipping

The hydraulic attachment slipping or tipping over and falling from the loading area of a lorry may cause serious injury.

- ▶ Place the hydraulic attachment on a pallet.
- ▶ Strap the hydraulic attachment to the pallet using suitable strapping (see illustration in chapter **Transport using a forklift truck**).
- ▶ Place the pallet with the hydraulic attachment on an anti-slip mat.
- ▶ Secure the hydraulic attachment to the loading area with ropes or chains; use any available transport lugs.
- Secure the hydraulic attachment on the pallet and the loading surface as shown in the following illustration.
- Observe all the applicable national/regional regulations on securing loads.

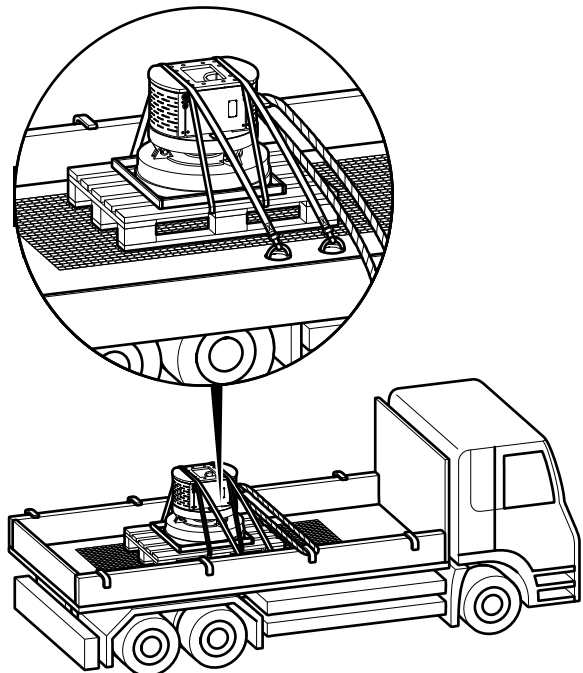

5 Installation

▲ **WARNING Hot hydraulic oil squirting out**

The hydraulic system is under high pressure. If hydraulic connections come loose or are disconnected, hydraulic oil will squirt out under high pressure. Hydraulic oil squirting out can lead to serious injury.

- ▶ Depressurise the hydraulic system before connecting or disconnecting the hydraulic circuits of the hydraulic attachment (see chapter **Depressurising the hydraulic system**).

NOTICE Environmental damage due to hydraulic oil

Hydraulic oil is environmentally harmful and must not penetrate the ground or enter the water table or water supplies.

- ▶ Collect any hydraulic oil which escapes.
- ▶ Dispose of it in accordance with the applicable environmental regulations.

5.1 Media/consumables

The following consumables are used when operating the hydraulic attachment:

5.1.1 Mineral hydraulic oil

All hydraulic oil brands prescribed by the carrier manufacturer are also suitable for use when operating the hydraulic attachment.

However, the oil should comply with viscosity class HLP 32 or higher.

In summer and in hot climates, oils of viscosity class HLP 68 or higher should be used.

In all other respects the regulations of the carrier manufacturer are to be taken into consideration.

Optimum viscosity range	= 30 - 60 cSt
Max. start viscosity	= 2000 cSt
Max. oil temperature	= 80 °C

- Check the oil filter!

An oil filter must be integrated in the tank line of the hydraulic system. The maximum mesh width allowed for the oil filter is 50 microns; it must have a magnetic separator.

5.1.2 Non-mineral hydraulic oil

NOTICE Mixed hydraulic oil

Never mix mineral and non-mineral hydraulic oils! Even small traces of mineral oil mixed in with non-mineral oil can result in damage to both the hydraulic attachment and the carrier. Non-mineral oil loses its biodegradability.

- ▶ Only use one type of hydraulic oil.

If you are using non-mineral oil it is imperative that the name of the oil in use be indicated when returning the hydraulic attachment for repair.

In order to protect the environment or on technical grounds, hydraulic oils are currently being used which are not classified as HLP mineral oils.

Before using hydraulic oils of this kind it is imperative to ask the carrier manufacturer whether operations with such fluids are possible.

Our hydraulic attachments are basically designed for use with mineral oils. Consult the Epiroc Customer Center / Dealer in your area before using other hydraulic oils approved by the carrier manufacturer. Following initial assembly and after any workshop repairs, our hydraulic attachments are subjected to a test run on a test bed powered by **mineral oil**.

5.2 Manufacturing the adapter plate

Construction Tools GmbH also supplies base plates to manufacture adapter plates alternatively to the adapter plates supplied.

NOTICE Adapter plate cracking

The adapter plate may crack if it is not designed for the high load.

- ▶ Take not only the weight of the hydraulic attachment but also the crowd force of the carrier, possible vibration etc. into account when dimensioning the adapter plate.
- ▶ Ensure that the design conforms to the state of the art.
- ▶ Have the web plates welded to the adapter plate base plate by a qualified welding specialist.

The base plate is made of the material EN10025-S355 J2G3.

- Have the web plates designed and manufactured or procure web plates to fit your carrier.
- Ensure that the web plates are welded to the base plate side marked "TOP".

The adapter plate must not strike in any position during operation of the hydraulic attachment.

Construction Tools GmbH does not design, manufacture or sell web plates for adapter plates.

5.3 Installing the adapter plate

NOTICE The adapter plate can come loose

The adapter plate can come loose if the fastening screws are not designed for local high loads.

- ▶ Only use the Allen screws of strength category 8.8 and the pairs of lock washers included in the delivery to attach the adapter plate or the base plate.
- Place the Hydro Magnet on a pallet within the range of the carrier.
- Remove the plate (D).
- Apply Anti-Seize to the Allen screw threads (C) before inserting them.

The contact faces of the screw head and the lock washers (B) must not be lubricated.

▲ WARNING Hands and fingers being cut off or hurt

Bores and surfaces can act like a pair of scissors and cut off or hurt parts of your body.

- ▶ Never use your fingers to check bores or fitting surfaces.
- Align the adapter plate (A) onto the Hydro Magnet as shown.

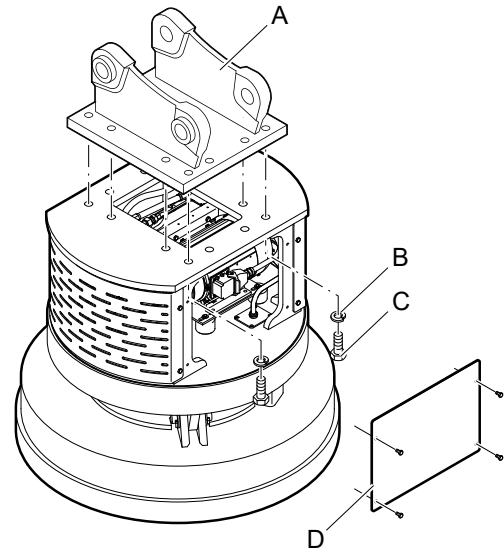

- Fit a pair of lock washers (B) onto every screw.
- Tighten the Allen screws (C) with an Allen key.
- Tighten the Allen screws (C) with the required tightening torque.
- Place the plate (D) and tighten.

Type	Key size	Tightening torque
HM 1500 F HM 1500 M	22	1500 Nm (1106 ft lbs)
HM 2000 F HM 2000 M	22	1500 Nm (1106 ft lbs)

5.4 Attaching the hydraulic attachment to the carrier

5.4.1 Mechanical mounting aspects

You need an assistant to attach the hydraulic attachment to the carrier.

- Agree on hand signals with your assistant, to enable him to help you place the carrier in the proper position to attach the hydraulic attachment.
- Lower the stick of the carrier into the holder provided on the adapter plate.

▲ WARNING Injury by impacts

A sudden movement of the carrier may cause your assistant to be hit and injured by the boom or the hydraulic attachment.

- ▶ Only move the boom very slowly and in a controlled manner while an assistant is within the danger zone.
- ▶ Always keep sight of your assistant.

▲ WARNING Hands and fingers being cut off or hurt

Bores and surfaces can act like a pair of scissors and cut off or hurt parts of your body.

- ▶ Never use your fingers to check bores or fitting surfaces.
- Let your assistant instruct you until the bores in the adapter plate (B) and in the stick (A) are properly aligned.
- Install the stick bolt (C) and lock it.

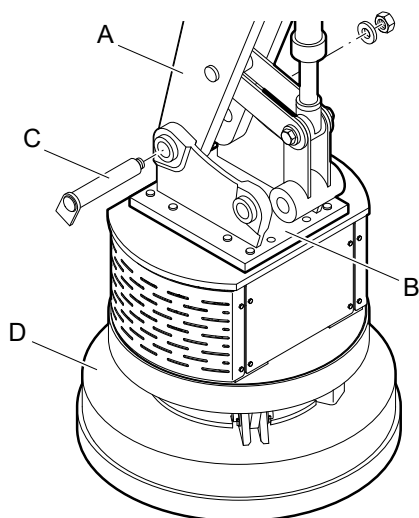

- Lift the hydraulic attachment (D).

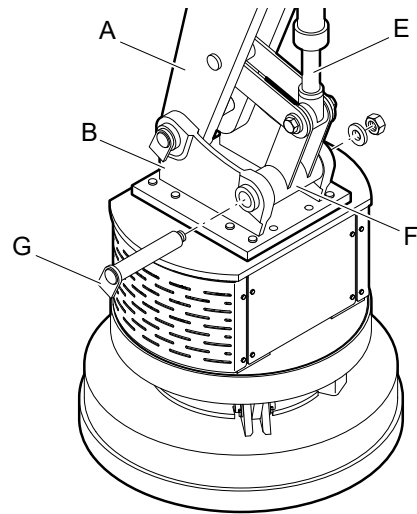

- Extend the bucket cylinder (E) until the bore in the linkage (F) aligns with the bore in the adapter plate (B).
- Install the linkage bolt (G) and lock it.
- Carefully move the bucket cylinder (E) into both end positions.

The adapter plate must not be stopped by the mechanical stops in either position. Consult the Epiroc Customer Center / Dealer in your area if the adapter plate is stopped by a mechanical stop.

5.4.2 First installation

▲ WARNING Risk of death due to defective first installation

Faults during the first installation or commissioning can lead to life-threatening situations and may cause considerable damage to property.

- ▶ Have the first installation exclusively conducted by authorised specialist personnel.
- ▶ Do not undertake unauthorised first installation.

▲ WARNING Unexpected movement

Sudden movements of the carrier may cause serious injury.

- ▶ Secure the carrier such that it cannot move unexpectedly.
- ▶ Observe the carrier manufacturer's instructions.

NOTICE Damage due to incorrect oil pressure setting
Incorrect oil pressure setting can result in severe damage to property and the environment.

- ▶ Start with installing the hydraulic attachment to the carrier. Check the oil pressure setting of pressure line »P«.
- ▶ Check and adjust the operational hydraulic flow according to operation pressure.
- ▶ Check the tank/return line pressure with an additional manometer mounted on the tank line »T«.
- ▶ Ensure the technical specifications are fulfilled (see chapter **Technical specifications**). If not, adjust the settings on the carrier.

5.4.3 Install separate leakage oil line

The separate leakage oil line including separate leakage oil filter must be installed from the shut-off valve on the boom to the carrier's hydraulic oil tank. The operator must pre-install a suitable connection on the carrier's hydraulic oil tank for the leakage oil line.

NOTICE Damage due to incorrect installed hydraulic hoses

Incorrectly installed hydraulic hoses can result in severe damage to property and the environment. The maximum pressure of the leakage oil line is 10 bar.

- ▶ Install hydraulic hoses such that they always possess sufficient play for turning and rotating motions of the boom.
- ▶ Always check the leakage oil line pressure when mounting the hydraulic attachment to a carrier.
- Install a separate leakage oil line along the hydraulic hoses on the boom and secure with cable ties.
- Install the separate leakage oil line (J) with leakage oil filter (I) to the connection on the carrier's hydraulic oil tank (K).

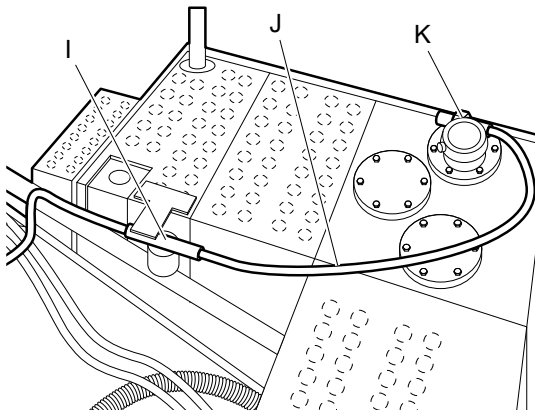

Follow the safety and operating instructions of the carrier when connecting the leakage oil line to the hydraulic oil tank.

- Attach the leakage oil line to the pre-installed connection on the hydraulic oil tank and tighten with the required tightening torque.
- Install the leakage oil filter at an appropriate location on the carrier.

5.4.4 Making the hydraulic connections

NOTICE Faulty hydraulic installation

The carrier must have a suitable hydraulic installation to operate the hydraulic attachment. Improperly installed lines and incorrectly rated sizes may cause the oil to heat up and the hydraulic attachment to be damaged.

- ▶ Only use hydraulic lines of the rated sizes as instructed (see chapter **Technical Specifications**).
- ▶ Check the rated size of the hydraulic lines on existing hydraulic installations! All supply and return lines for the hydraulic oil must have a sufficient inside diameter and wall thickness.
- ▶ Route all hydraulic hoses in a torsion-free manner.
- Switch off the carrier.
- Depressurise the hydraulic system by releasing the carrier's hydraulic tank pressure.
- Close all shut-off valves in the installation at the boom, if no quick couplings are used.

NOTICE Damage to hydraulic parts

Polluted hydraulic lines and connections may enable sand, fragments of material and dirt to penetrate the hydraulic attachment and damage the hydraulic parts.

- ▶ Clean the hydraulic lines and connections prior to connecting the hydraulic lines.
- Have dirty hydraulic lines rinsed through by a specialist company.
- Clean dirty hydraulic line connections with a suitable grease-dissolving universal cleaner.
- Observe the cleaner manufacturer's information on safety and use.
- Connect the hoses of the pressure line »P«, the tank line »T« and the hose for the function »magnet plate on/off« at the boom.

- Remove the screw caps from the connections »A«, »F« and »G« of the Hydro Magnet and keep them in a safe place.

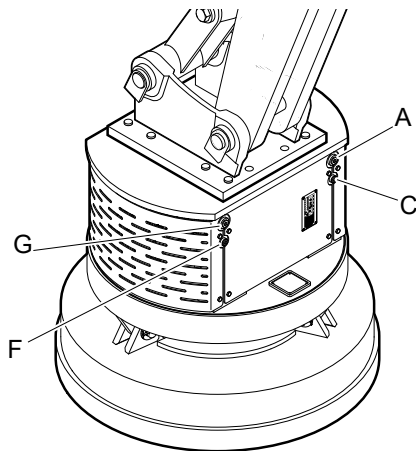

- Check that the connections on the Hydro Magnet and on the hoses are not damaged.
- Change any damaged connections.
- Connect the carrier's pressure line »P« in a torsion-free manner to port »G«.
- Connect the carrier's tank line »T« in a torsion-free manner to port »A«.
- Connect the carrier's hose for function »magnet plate on/off« in a torsion-free manner to port »F« (Not required for Hydro Magnets operated by joystick activation.).)

▲ WARNING Hydraulic hose flailing about

Pressurised hydraulic hoses will flail about if a bolted connection comes loose or becomes loosened. A hydraulic hose flailing about may cause serious injuries.

- ▶ Tighten the fastening screws with the right tightening torque.

5.4.5 Optional equipment

The Hydro Magnets can be equipped with an optional Joystick activation kit. For a better control the display can be placed in the carrier cabin. A radio modem attached to the Hydro Magnet transmits the generator information to the display in the carrier cabin via the antenna. The antenna can either be connected directly to the display or outside of the carrier cabin to a magnetic antenna mount. In this case the connection via an antenna cable from the magnetic antenna mount to the display is necessary. For the supply voltage the display has to be connected to the carriers supply.

Note: You must not install the radio modem when the radio transmission could disturb other facilities or under poor conditions for radio transmission.

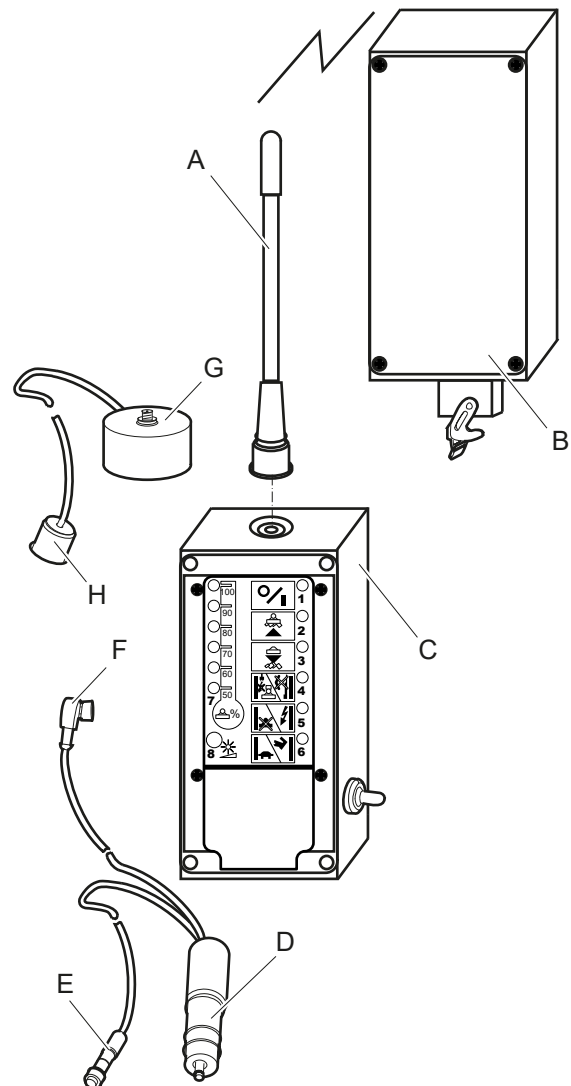

- Switch off the carrier and wait about a minute for the magnetic field to dissipate.
- Place the display (C) in the carrier cabin in sight of the carrier driver.
- Fasten the display (C) with four screws, tape or magnets in the carrier cabin.
- Connect the antenna (A) directly to the display (C).

Or, if you want to place the antenna outside of the carrier cabin:

- Connect the antenna (A) to the magnetic antenna mount (G).

- Place the magnetic antenna mount (G) on the carrier so that a good transmission to the Hydro Magnet is possible.
- Connect the antenna cable (H) to the display (C).

After connecting the antenna:

- Connect plug (F) to the display (C).
- For supply voltage of the display (C) connect plug (D) with the power supply of the carrier, e.g. cigarette lighter.
- Mount button (E) to the carrier's joystick.
- To install the radio modem (B) unscrew the screws (J) and remove the cover (I) from the Hydro Magnet.

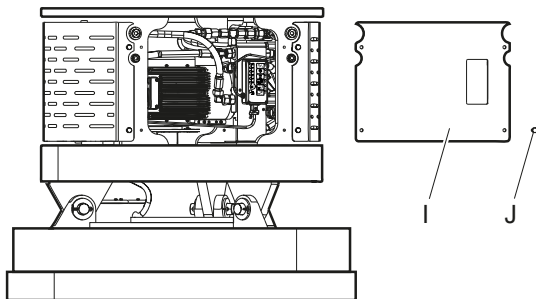

- Unplug the connections (K) and (L) and remove the display (A).

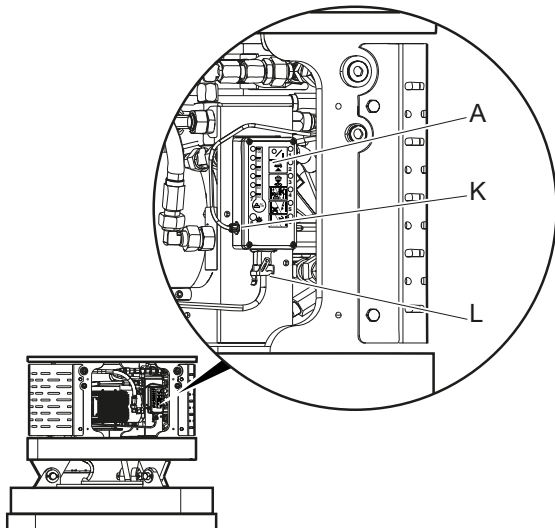

- Fasten the radio modem (B) with magnets at the Hydro Magnet.

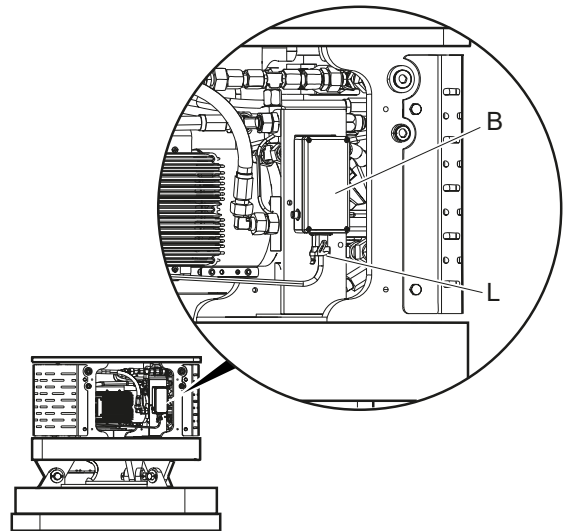

- Plug in connection (L) and fit cover (I).

Radio channel

Usually you do not change the factory setting of the radio channel. If it is necessary to change the radio channel please consult the Epiroc Customer Center / Dealer in your area.

5.5 Removing the hydraulic attachment from the carrier

- Place the hydraulic attachment on timber support blocks.

5.5.1 Dismantling the hydraulic connections

▲ WARNING Unexpected movement

Sudden movements of the carrier may cause serious injury.

- ▶ Secure the carrier such that it cannot move unexpectedly.
- ▶ Observe the carrier manufacturer's instructions.

▲ WARNING Hydraulic hose flailing about

Pressurised hydraulic hoses will flail about when bolted connections have come loose or have been loosened. A hydraulic hose flailing about may cause serious injuries.

- ▶ Depressurise the hydraulic system before disconnecting a hydraulic hose (see chapter **Depressurising the hydraulic system**).

▲ WARNING Hot parts

Parts of the Hydro Magnet, hoses, pipes and fittings become very hot during operation. Touching them may lead to burns.

- ▶ Never touch hot parts.
- ▶ If you have to carry out activities where you have to touch the parts, wait for them to cool down first.
- Close all shut-off valves in the installation at the boom if no quick couplings are used.
- Disconnect the hose lines to and from the hydraulic attachment at the boom side.
- Close off all open hose ends.

5.5.2 Mechanical disassembly

- You need an assistant to remove the hydraulic attachment.
- Agree on hand signals with your assistant, to enable him to help you move the boom.

▲ WARNING Injury by impacts

A sudden movement of the carrier may cause your assistant to be hit and injured by the boom or the hydraulic attachment.

- ▶ Only move the boom very slowly and in a controlled manner while an assistant is within the danger zone.
- ▶ Always keep sight of your assistant.

▲ WARNING Metal chips shooting off

When hammering out bolts, chips may shoot off and cause serious eye injuries.

- ▶ Wear safety glasses when hammering out the bolts.
- Remove the bolt locks from the stick and linkage bolts.
- Drive out the linkage bolt with a steel arbor and a hammer.
- Switch on the carrier.
- Retract the bucket cylinder.
- Drive out the stick bolt with a steel arbor and a hammer.
- Move the carrier stick out of the adapter plate.

5.6 Removing the adapter plate

- Loosen the fastening screws of the adapter plate.
- Lift the adapter plate with a suitable lifting equipment and put it down on timber support blocks.
- Save the fastening screws and the pairs of lock washers for future use.

6 Operation

▲ DANGER Danger to life through electric shock

During operation, dangerous voltages may occur. This can lead to serious injury or even death.

- ▶ Never open the Hydro Magnet housing during operation.
- ▶ Never loosen or connect any cables during operation.
- ▶ Never hold the beam of a high-pressure cleaner on the Hydro Magnet. There is a danger of electric shock and danger of damage.

▲ DANGER Danger to life through electric shock

In the event of an insulation fault the built-in system protection "protective separation" is no longer effective. Due to these errors dangerous contact voltages can occur on metal parts. This can lead to serious injury or even death.

- ▶ Turn off the carrier immediately. Secure the carrier against being switched on again (for example, by removing the ignition key and keeping it safe).
- ▶ Contact the Epiroc Customer Center / Dealer in your area.
- ▶ Only use the Hydro Magnet again after all damage and defects have been repaired.

▲ DANGER Danger to life through electric shock

Overheating can damage the control electronics. It is not guaranteed that under this condition, safe operation of the system is ensured. Loads can fall uncontrollably due to electronic failure. This can lead to serious injury or even death.

- ▶ Immediately lower the Hydro Magnet load if the LEDs 4, 5, 6 light up and 100 % flashes.
- ▶ Never cool the Hydro Magnet with water.
- ▶ Turn off the carrier and secure it against being switched on again (for example, by removing the ignition key and keeping it safe).
- ▶ Contact the Epiroc Customer Center / Dealer in your area.

▲ WARNING Risk of magnetic field

The electromagnetic field can cause interference and damage to electronic devices (such as cardiac pacemakers). It can also move ferro-magnetic objects inadvertently. This can lead to serious injury or even death.

- ▶ Persons with cardiac pacemakers must keep a safe distance of at least 2 m from the Hydro Magnet.
- ▶ Persons with metal prostheses must keep a safe distance of at least 2 m from the Hydro Magnet.
- ▶ No person may bear or carry ferro-magnetic objects in the field of Hydro Magnet, since it will exert an attracting force and could cause bruising or injury.
- ▶ Keep a safe distance of at least 2 m from the Hydro Magnet with electronic devices such as computers, monitors, credit cards, mobile phones, magnetic cards, etc..
- ▶ Secure a spacious working area for the Hydro Magnet with warning signs, to alert personnel and others to the dangers of the magnetic field.

▲ WARNING Risk of death due to suspended loads

When lifting loads these can swivel and fall off. This can result in serious injuries or even death.

- ▶ Shut off the danger zone in a radius of 20 m around the Hydro Magnet with a construction fence.
- ▶ Never stand underneath or in the swivelling range of the Hydro Magnet.
- ▶ When operating the Hydro Magnet, ensure that you always have a clear view of the load. Let an assistant instruct you, if this is not possible. The assistant must be located outside the danger zone.
- ▶ When leaving the workplace, lower the Hydro Magnet to the floor/ground.

▲ WARNING Hot hydraulic oil under high pressure

Hydraulic oil will squirt out under high pressure if there is a leakage. The jet of oil might penetrate people's skin and cause permanent damage. Hot hydraulic oil can cause burns.

- ▶ Never use your hands to find leaks.
- ▶ Always keep your face away from a possible leak.
- ▶ If hydraulic oil has penetrated your skin consult a doctor immediately.

NOTICE Environmental damage due to hydraulic oil

Hydraulic oil is environmentally harmful and must not penetrate the ground or enter the water table or water supplies.

- ▶ Collect any hydraulic oil which escapes.
- ▶ Dispose of it in accordance with the applicable environmental regulations.

▲ WARNING Hot parts

Parts of the Hydro Magnet, hoses, pipes and fittings become very hot during operation. Touching them may lead to burns.

- ▶ Never touch hot parts.
- ▶ If you have to carry out activities where you have to touch the parts, wait for them to cool down first.

NOTICE Damage due to overheating

Continuous operation at high duty cycles can lead to damage or overheating of the magnet plate.

- ▶ Operate the Hydro Magnet when LED 7 lights up in the range between 50 % and 70 %.

NOTICE Mechanical damage

Through to high rotation speeds, the generator can mechanically be damaged.

- ▶ Operate the Hydro Magnet so that the rotational speed of the generator is within the permitted tolerances. LED 6 must not flash red.

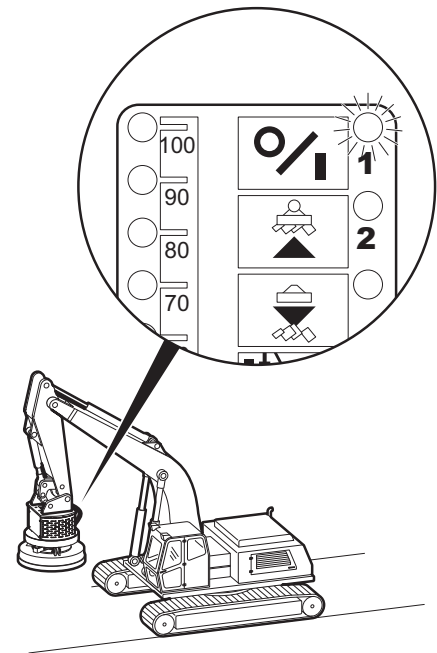
**6.1 Making operational readiness**

- Start the carrier.

The Hydro Magnet is operable, when the carrier runs at the required revolution speed, and drives the generator.

- Watch the hydraulic lines.
- Switch off the Hydro Magnet immediately if oil leaks from the hydraulic lines or other malfunctions occur.
- Depressurise the hydraulic system (see chapter **Depressurising the hydraulic system**).
- Only use the Hydro Magnet again after having repaired all leaks and operating defects.
- Wait until the display lights up LED 1 green.

- Briefly press the control button.

LED 2 lights up. The magnet plate is magnetized.

- Briefly press the control button.

LED 3 lights up. The magnet plate is demagnetized.

The quick magnetization and demagnetization is activated.

6.2 Switching the Hydro Magnet on and off

After properly attaching the hydraulic attachment to the carrier, the hydraulic attachment can be operated using the carrier's hydraulic system. All functions for normal carrier operation remain intact.

The hydraulic attachment is switched on and off using electrical and hydraulic signals.

If you have any questions about electric / hydraulic commands, consult the carrier manufacturer and/or the Epiroc Customer Center / Dealer in your area.

- Switch the hydraulic attachment on and off, as described in the carrier's operating instructions.
- When leaving the driver's cab, set the safety switch/lever for the electrical / hydraulic attachment installation to the „OFF“ position.

Carry out the above actions to prevent any unintended start-up of the hydraulic attachment.

Emergency stop function

In an emergency, the Hydro Magnet can be safely shut down by switching off the carrier.

▲ DANGER Danger to life through electrical voltage

There may exist dangerous voltages up to max. 45 seconds in and close to the system after switching off the carrier.

- ▶ Only touch the Hydro Magnet when the voltages are degraded.

- Consult the Epiroc Customer Center / Dealer in your area if LED 6 lights up.
- Briefly press the control button again, if no defects in functioning occur.
The lifted load drops.
- Only use a Hydro Magnet operating without functional defects.

6.3 Functional test

Prior to commissioning, the load capacity of the magnet plate has to be checked by a dynamic load function test with the material to be lifted.

- Prepare a test load: nominal load x 1.1.
- Lift the Hydro Magnet.
- Check on Hydro Magnets M version that the chains are not twisted. This may limit the life span. Lower the Hydro Magnet again, when the chains are twisted. Switch off the carrier and remove the twist.
- Position the magnet plate in the center of the test load, at an area as straight as possible.
- Briefly press the control button.
- Lift the load slowly and slowly rotate the boom.
- It must be possible to lift the load without difficulty. No parts of the test load may fall off the magnet plate.
- Make sure that:- this is done without difficulty,- no unusual noises are heard,- no deformation and - no yielding of the structure can be seen.
 - this is done without difficulty,
 - no unusual noises are heard,
 - no deformation and
 - no yielding of the structure can be seen.
- Switch off the Hydro Magnet immediately, if defects in functioning occur. Switch off the carrier.
Only operate a Hydro Magnet if it has no functional defects.
- Repeat the load function test with full lift speed and turn the boom. Lift the load about 1 m above ground surface.
- LED 6 (Red error indicator) may not light up.

6.4 Correct operation

6.4.1 Lift load

- Place the magnet plate on the load to be lifted.
- Briefly press the control button.

LED 2 lights up. The magnet plate is magnetized and remains on until the control button is pressed again. The load is applied.

Note: If you press the control button again shortly after switching on the magnet plate (even when the magnetization process is running), the magnetization is cancelled and the automatic quick demagnetization starts immediately. In this case, the system may require several magnetization processes until the maximum tractive force of the magnet plate is available again.

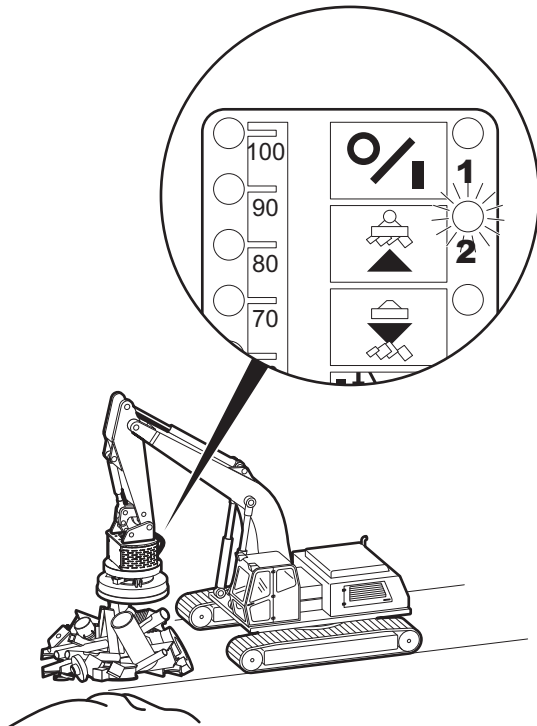

6.4.2 Drop load

- Move the magnet plate with the suspended load into position for dropping the load.
- Briefly press the control button.

LED 2 goes out and LED 3 lights up for the duration of the automatic quick demagnetization.

The magnet plate is demagnetized. The load decreases from the magnet plate.

Note: When pressing the control button again during the quick demagnetization process (LED 3 lights up), the quick demagnetization is interrupted and the demagnetization of the magnet plate is continued at the "normal" speed, i.e. it takes much longer.

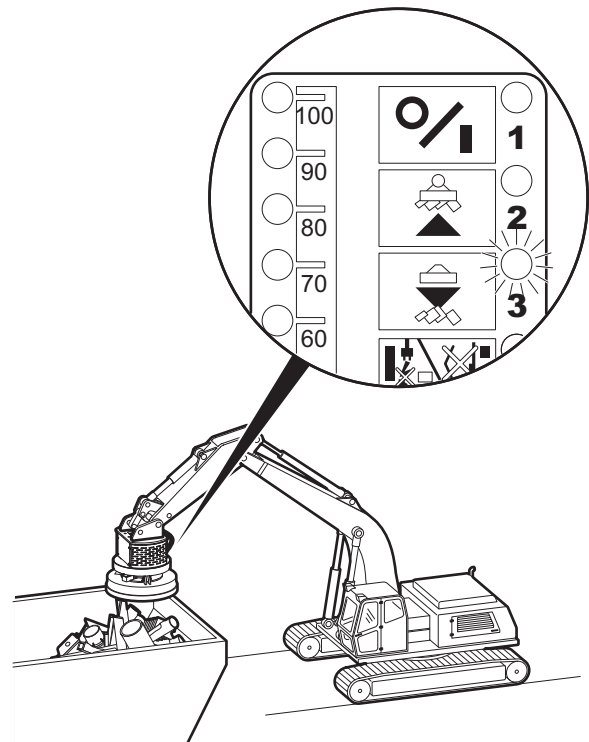

6.5 Prohibited operation

6.5.1 Unsafe base

▲ WARNING Danger of tipping

The carrier can topple over and cause injuries and damage.

- ▶ Only work with the hydraulic attachment when the carrier is on a safe base.

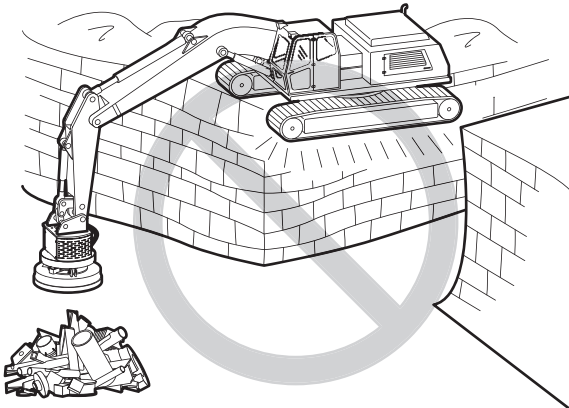

6.5.2 Non-load bearing suspended ceilings

▲ WARNING Danger of collapse

The carrier can collapse and cause injuries and damage.

- ▶ Only work with the hydraulic attachment when the carrier is on a load-bearing suspended ceiling.

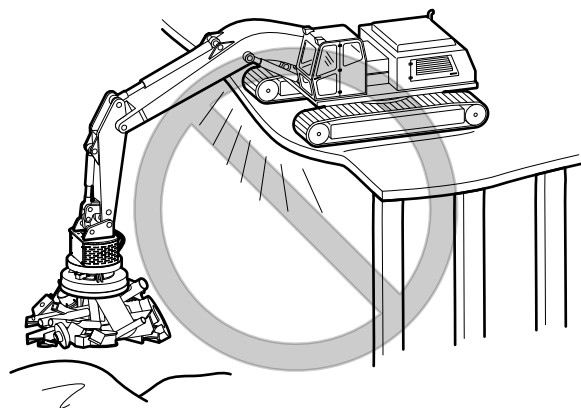

6.5.3 Use over the chain

▲ WARNING Danger of tipping

The carrier can topple over and cause injuries and damage.

- ▶ Never work with full delivery sideways in the direction of movement.

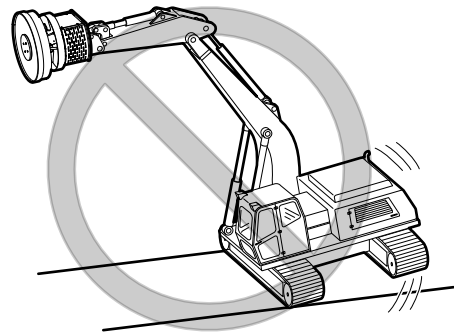

6.5.4 Moving the carrier

- Never relocate the carrier sideways by placing the hydraulic attachment on the ground to lift the carrier.

This would seriously damage the hydraulic attachment.

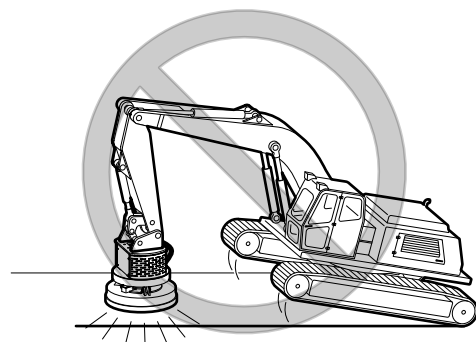

6.5.5 Impacting/chopping

- Do not use the hydraulic attachment to impact or chop to destroy material.

This would seriously damage the hydraulic attachment.

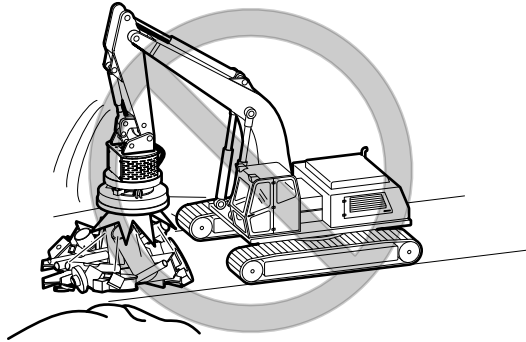

6.5.6 Use under water

- Never use the hydraulic attachment under water.

This would seriously damage the hydraulic attachment and may damage the whole hydraulic installation.

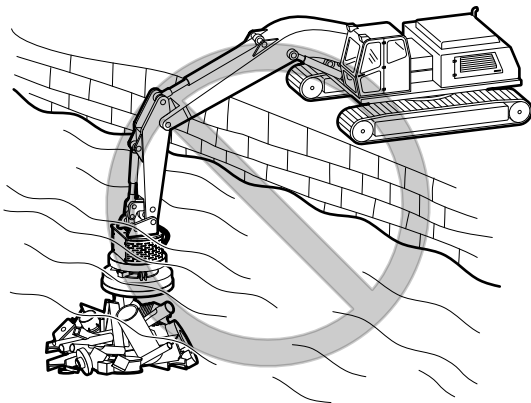

6.5.7 Cylinder end positions

- Reposition the carrier to avoid working with the cylinder in its end positions.

Avoid operating the hydraulic attachment when the carrier stick and bucket cylinder are in one of their end positions. These end positions have damping facilities; the hydraulic cylinder may be damaged by prolonged use while in its end positions.

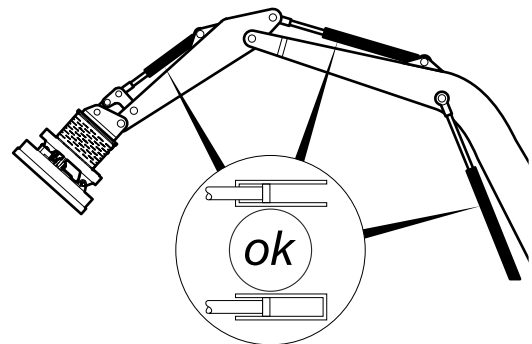
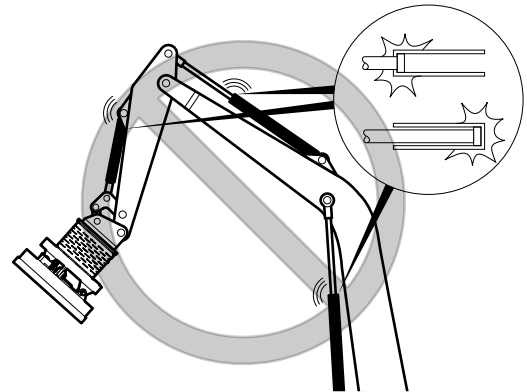

7 Maintenance

The components of the Hydro Magnet are basically maintenance free. The Hydro Magnet contains no parts that can be replaced or repaired by the user.

Nevertheless, you must perform the following maintenance procedures regularly to ensure reliable operation. We recommend that you document maintenance procedures in a maintenance booklet.

You may only perform the maintenance procedures described in this manual. Damage and defects must be remedied immediately by authorized and qualified personnel from Epiroc.

Only use the Hydro Magnet again after all damage and defects have been repaired. Repairs may only be carried out by authorized and trained personnel from Epiroc.

▲ **DANGER Danger of electric shock**

Working on a powered Hydro Magnet can cause a lethal electric shock.

- ▶ Perform visual control and maintenance work on a Hydro Magnet only in the turned-off and de-energized state.
- ▶ Secure the carrier against unintentional starting (for example by removing the ignition key and keeping it safe).

▲ **WARNING Hot hydraulic oil squirting out**

The hydraulic system is under high pressure. If hydraulic connections come loose, hydraulic oil will squirt out under high pressure. Hydraulic oil squirting out can lead to serious injury.

- ▶ Immediately switch off the hydraulic attachment and the carrier if you detect any leaks in the hydraulic circuits.
- ▶ Depressurise the hydraulic system (see chapter **Depressurising the hydraulic system**).
- ▶ Repair any leaks before operating the hydraulic attachment again.

▲ **WARNING Hot hydraulic oil squirting out**

The hydraulic system is under high pressure. Hydraulic oil escaping out can lead to serious injury.

- ▶ Immediately switch off the hydraulic attachment and the carrier if you detect any leaks in the hydraulic circuits.
- ▶ Do not inspect for possible leaks with your fingers or other parts of the body, but use a piece of cardboard instead, holding it up to the suspected leakage site.
- ▶ Examine the cardboard for traces of liquid.
- ▶ Depressurise the hydraulic system (see chapter **Depressurising the hydraulic system**).
- ▶ Repair any leaks before operating the hydraulic attachment again.

▲ **WARNING Hot parts**

Parts of the Hydro Magnet, hoses, pipes and fittings become very hot during operation. Touching them may lead to burns.

- ▶ Never touch hot parts.
- ▶ If you have to carry out activities where you have to touch the parts, wait for them to cool down first.

▲ **WARNING Accidental start**

If the hydraulic attachment is started by accident this may lead to serious injury.

- ▶ Follow the instructions in the Operating Instructions of the carrier to prevent the hydraulic attachment starting by accident.

▲ **WARNING Unexpected movement**

Sudden movements of the carrier may cause serious injury.

- ▶ Secure the carrier such that it cannot move unexpectedly.
- ▶ Observe the carrier manufacturer's instructions.

NOTICE Environmental damage due to hydraulic oil

Hydraulic oil is environmentally harmful and must not penetrate the ground or enter the water table or water supplies.

- ▶ Collect any hydraulic oil which escapes.
- ▶ Dispose of it in accordance with the applicable environmental regulations.

7.1 Maintenance schedule

Before starting work shift	<p>Check the hydraulic lines for leaks.</p> <p>Check that the pipe clamps on the carrier are tight.</p> <p>Check the bolted connections at the adapter plate and tighten as required.</p> <p>Clean display.</p> <p>Check the wear limit of the wear ring of the magnet plate.</p> <p>Check the connecting cable of the magnet plate for damage.</p> <p>Check the fixing of the magnet plate.</p> <p>HM 1500 M, HM 2000 M: Check chain</p>
during and after the first 50 operating hours	<p>Tighten the screw connections daily during the first 50 operating hours.</p> <p>Replace the oil filter cartridges after the first 50 operating hours.</p>
weekly	<p>Check the bolted connections and tighten as required.</p> <p>Check the adapter plate for cracks.</p>
every 500 operating hours	<p>Check the oil filter and replace as required.</p>
if necessary	<p>Replace bent and damaged pipes.</p> <p>Replace damaged hoses.</p> <p>Check the adapter plate bolts for wear.</p>
every 20,000 operating hours	<p>Have both ball-bearings of the generator replaced. Contact the Epiroc Customer Center / dealer in your area.</p>

7.2 Depressurising the hydraulic system

Even when you have switched off the carrier, a considerable residual pressure can still be present in the hydraulic system.

A residual pressure can still be present in the hydraulic attachment even after you have disconnected the quick-release couplings or closed the shut-off valves.

The hydraulic attachment can only be depressurized using the hydraulic system of the carrier, by allowing hydraulic oil to drain to the tank via the return connection.

Depending on the type of hydraulic attachment, the internal leaks, the oil temperature, the type of hydraulic oil and the design of the hydraulic installation of the carrier, the time required to relieve the pressure can vary.

Observe the following steps in order to depressurise the hydraulic attachment:

1. Ensure that the hydraulic oil in the hydraulic attachment and in the carrier has a temperature of at least 0 °C (32 °F). If necessary, pre-heat it to at least 0 °C (32 °F).
2. The hydraulic attachment must be connected to the hydraulic system of the carrier device, i.e. the hydraulic hoses must be connected up and the respective shut-off valves in the supply pipe and in the connection to the tank must be opened.
3. Place the hydraulic attachment on timber support blocks laying on the ground.
4. Depressurise the hydraulic system according to the manufacturer's safety and operating instructions for the carrier.
5. You must wait at least another 60 minutes until the pressure has been relieved through leakages.
6. When you have made sure that no more pressure is present in the hydraulic system, you must disconnect the hydraulic connection to the carrier. Close the shut-off valves or disconnect the quick-release couplings, so that no hydraulic oil can flow back from the carrier.

7.3 Cleaning

- Before starting your work shift always clean the display with a damp, soft cloth.

7.4 Check wear ring of the magnet plate

- Before starting your work shift, always check that the wear of the wear ring is within the tolerance.

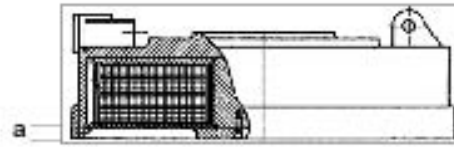

- Consult the Epiroc Customer Center / Dealer in your area if the wear limit "a" of 10 mm is reached.

7.5 Check the fixing of the magnet plate

- Before starting your work shift, always check the fixing of the magnet plate.
- All bolts have to be fixed with a split pin (A).

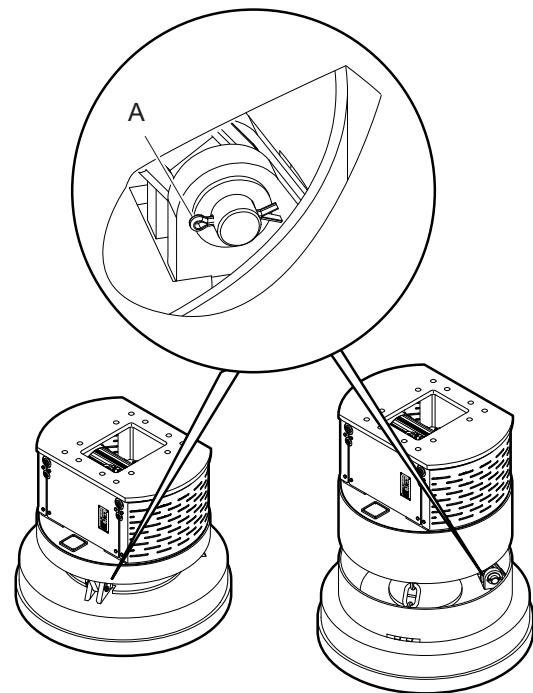

- Immediately replace missing split pins.

7.6 Check chain (Version M)

- Before starting your work shift, always check that the chains are not elongated and are therefore worn.

- It should not be possible to push the attached gauge over the chain link.

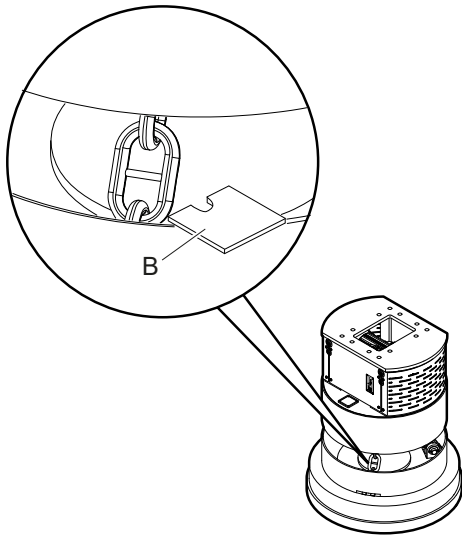

- Check that the hook on which the chains are mounted, is undamaged and is provided with a safety device (carabiner).
- Let a worn chain or hook be replaced. Consult the Epiroc Customer Center / Dealer in your area.

7.7 Checking the connecting cable of the magnet plate

- Before starting your work shift, always carry out a visual check of the connecting cable of the magnet plate.
- Make sure the insulation is undamaged and the cable is correct connected.
- Let a damaged connecting cable replace. Consult the Epiroc Customer Center / Dealer in your area.

7.8 Checking bolted connections

- Secure the carrier such that it cannot move unexpectedly.
- Check all bolted connections regularly for tight fit (see Chapter **Bolted connections / Tightening torques**).
- Tighten loose bolted connections and hose clamps to the torque required (see Chapter **Bolted connections / Tightening torques**).

7.9 Checking the hydraulic attachment and adapter plate for cracks

- Secure the carrier so that it cannot move unexpectedly.
- Check all the hydraulic attachment and adapter plate load-bearing parts and welds for cracks prior to every shift.
- Ensure repair or refinishing in good time to prevent greater damage.

7.10 Checking the adapter plate bolts for wear

- Carry out this visual check whenever the hydraulic attachment has been removed from the carrier.
- Check the adapter plate bolts for excessive wear such as cracks, pitting or severe erosion.
- Rework or replace worn bolts.

7.11 Checking hydraulic lines

- Secure the carrier such that it cannot move unexpectedly.
- Perform a visual inspection of all lines (pipes and hoses) from the pump to the hydraulic attachment and back to the tank, before starting work.
- Tighten loose bolted connections and hose clamps to the torque required (see Chapter **Bolted connections / Tightening torques**).
- Replace damaged pipes and/or hoses.

7.12 Checking and cleaning the hydraulic oil filter of the carrier

An oil filter must be integrated in the return circuit of the hydraulic system. The maximum mesh width allowed for the oil filter is 50 microns; it must have a magnetic separator.

- Secure the carrier such that it cannot move unexpectedly.

- Change the oil filter cartridge after the first 50 operating hours.
- Check the oil filter **every** 500 operating hours and replace if it is necessary.

7.13 Bolt connections / Tightening torques

The bolt connections of Hydro Magnets are subjected to very high loads.

- Tighten any loose connections without exceeding the recommended tightening torques.

Connection point		Interval	Type of spanner / size	Tightening torque
Adapter plate* (fixing bolts)	A	daily	Allen key / 22 mm (0.87 in.)	1500 Nm (1106 ft lbs)
Hydraulic ports »P« and »T«	B	weekly	open-ended wrench / 10 mm (0.39 in.)	275 Nm (203 ft lbs)
Hydraulic port »mag- net plate on/off«	C	weekly	open-ended wrench / 24 mm (0.95 in.)	70 + 10 Nm (52 + 7 ft lbs)

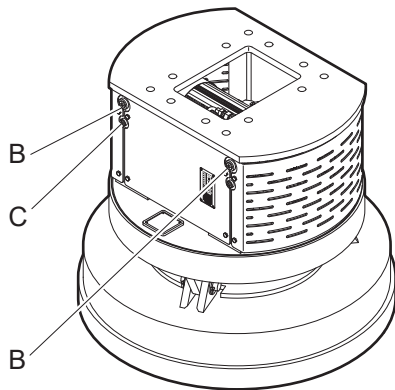
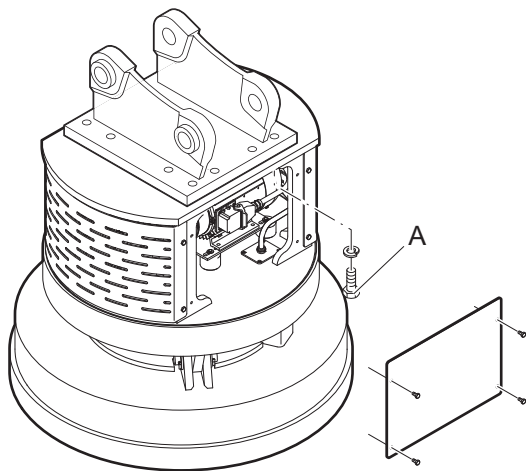

8 Troubleshooting

8.1 Control centre fault - reset

Cause	Remedy	By
For certain errors, it may be necessary to perform a reset of the system.	Switch off the carrier. Wait until all LEDs on the display are off, but at least 45 seconds. The display is only fully de-energized after this time and the reset can then be performed correctly. Switch on the carrier again.	Carrier driver

8.2 LED 4 lights up: Interruption

Cause	Remedy	By
Electrical power supply of magnet plate interrupted.	Turn off the carrier and secure it against being switched on again (for example, by removing the ignition key and keeping it safe). let the connecting cable be replaced.	Workshop or Epiroc Customer Center / Dealer in your area

8.3 LED 4 flashes: Interruption of the connection between the control center and the display

Cause	Remedy	By
Error at the interface between the control center and the display. The control center stops responding.	Perform a reset. If the error persists after the reset: Turn off the carrier. Contact the Epiroc Customer Center / Dealer in your area.	Carrier driver and Epiroc Customer Center / Dealer in your area

8.4 LED 5 lights up: Overload

Cause	Remedy	By
The attached magnet plate is too large for the system. The built-in overload and fault current limiter of the generator is active.	Turn off the carrier and secure it against being switched on again (for example, by removing the ignition key and keeping it safe). Contact the Epiroc Customer Center / Dealer in your area.	Carrier driver and Epiroc Customer Center / Dealer in your area
The attached magnet plate is too cold.	Note: If the magnet plate is very cold, it is possible that the overload warning lights up on the display in the first few operating minutes. However, this is only a warning, the system is in safe operating condition. Once the magnet plate is heated during cyclic switching, the warning must go out after a certain time. This time can take 5 up to 25 minutes depending on the magnet plate type and operation mode. In case of doubt consult the Epiroc Customer Center / Dealer in your area.	Epiroc Customer Center / Dealer in your area

8.5 LED 5 flashes: System failure

Cause	Remedy	By
A safety critical error has occurred. The output to the magnet plate is switched off immediately.	Turn off the carrier and secure it against being switched on again (for example, by removing the ignition key and keeping it safe). Have the connection cable replaced.	Workshop or Epiroc Customer Center / Dealer in your area

8.6 LED 6 lights up: Underspeed

Cause	Remedy	By
The generator is running at underspeed. It no longer delivers full power. When turning, it is possible that the magnet plate is not magnetized with full impulse voltage. The efficiency of the system is reduced. The LED goes off when the rotation speed is back within the tolerance limits.	Operate the generator at a rotation speed that is within the allowable tolerances.	Carrier driver

8.7 LED 6 flashes: Overspeed

Cause	Remedy	By
The generator is running at overspeed. After dropping the load, no switching on again is possible. The LED goes off when the rotation speed is back within the tolerance limits.	Operate the generator at a rotation speed which is within the allowable tolerances.	Carrier driver

8.8 Relative duty cycle greater than or equal to 80 %

Cause	Remedy	By
Relative duty cycle greater than or equal to 80 %.	Reduce the on-period of the magnet plate until the display is back to the normal range between 50 % and 70 %.	Carrier driver

8.9 LEDs 4, 5 and 6 flash simultaneously: Insulation fault detected

Cause	Remedy	By
Insulation fault detected	If an insulation fault is detected, a restart is automatically blocked. The Hydro Magnet cannot be switched on again. This is a safety risk! Lethal contact voltages can occur on metal parts! Contact a qualified electrician immediately.	Workshop or Epiroc Customer Center / Dealer in your area

8.10 LED 4, 5, 6 light up and 100 % flash: Pre-alarm over temperature of the control electronics

Cause	Remedy	By
The temperature in the control electronics, has exceeded the pre-alarm limit value.	Turn off the carrier and secure it against being switched on again (for example, by removing the ignition key and keeping it safe). Check that the cooling air openings are free and that the cooling air can flow freely. Clean the cooling air openings with a damp cloth if necessary. If overtemperature occurs repeatedly contact the Epiroc Customer Center / Dealer in your area.	Carrier driver and Epiroc Customer Center / Dealer in your area
	Let be checked if there is dirt on the cooling air openings on the generator back. Dirt can impede the flow of cooling air. Let the cooling air openings be cleaned.	

8.11 LED 4, 5, 6 and 100 % flash: Over temperature control electronics

Cause	Remedy	By
The temperature in the control electronics has exceeded the allowed limit, and the system is switched off immediately without warning.	Turn off the carrier and secure it against being switched on again (for example, by removing the ignition key and keeping it safe). Check that the cooling air openings are free and that the cooling air can flow freely. Clean the cooling air openings with a damp cloth if necessary. If overtemperature occurs repeatedly contact the Epiroc Customer Center / Dealer in your area.	Carrier driver and Epiroc Customer Center / Dealer in your area
	Let be checked if there is dirt on the cooling air openings on the generator back. Dirt can impede the flow of cooling air. Let the cooling air openings be cleaned.	

8.12 No LEDs lights up even though the magnet plate is switched on

Cause	Remedy	By
No LEDs lights up even though the magnet plate is switched on.	Check generator speed. Measure generator resistance. Check cable from pressure switch to display.	Epiroc Customer Center / Dealer in your area

8.13 Magnet plate cannot be switched on

Cause	Remedy	By
Magnet plate cannot be switched on but LED 1 lights up green on display .	Check Pressure switch. Check cable from pressure switch to display.	Epiroc Customer Center / Dealer in your area

8.14 No LEDs lights up even though the magnet plate is switched on

Cause	Remedy	By
No LEDs lights up even though the magnet plate is switched on.	Check generator speed. Measure generator resistance. Check cable from pressure switch to display.	Epiroc Customer Center / Dealer in your area

8.15 Magnet plate cannot be switched on

Cause	Remedy	By
Magnet plate cannot be switched on but LED 1 lights up green on display .	Check Pressure switch. Check cable from pressure switch to display.	Epiroc Customer Center / Dealer in your area

8.16 Oil leaks from Hydro Magnet

Cause	Remedy	By
Oil leakage	Visual check of all connections. Tighten loose connections.	Carrier driver
Oil leakage on hydraulic motor	Change seals on hydraulic motor.	Epiroc Customer Center / Dealer in your area

9 Repair

▲ DANGER Danger of electric shock

Working on a powered Hydro Magnet can cause a lethal electric shock.

- ▶ Perform repair work on a Hydro Magnet only in the turned-off and de-energized state.
- ▶ Secure the carrier against unintentional starting (for example by removing the ignition key and keeping it safe).

▲ WARNING Risk of injury

Non-professional repair of the Hydro Magnet may lead to serious injury and property damage.

- ▶ Repair is only permitted if carried out by professionals trained by Construction Tools Deutschland GmbH. These professionals must follow all safety instructions and guidelines for repair.
- ▶ Consult the Epiroc Customer Center / Dealer in your area.

9.1 Sending in the hydraulic attachment for repairs

NOTICE Mixed hydraulic oil

Never mix mineral and non-mineral hydraulic oils! Even small traces of mineral oil mixed in with non-mineral oil can result in damage to both the hydraulic attachment and the carrier. Non-mineral oil loses its biodegradability.

- ▶ Only use one type of hydraulic oil.
- Always specify which hydraulic oil has been used when sending in the hydraulic attachment to have it repaired.

10 Storage

▲ **WARNING Hydraulic attachment falling**

The hydraulic attachment is heavy. If it falls down from where it is stored, injury may be the result.

- ▶ Store the hydraulic attachment so that it cannot topple over or fall down.

NOTICE Environmental damage due to hydraulic oil

Hydraulic oil is environmentally harmful and must not penetrate the ground or enter the water table or water supplies.

- ▶ Collect any hydraulic oil which escapes.
- ▶ Dispose of it in accordance with the applicable environmental regulations.
- Even for short storage always place the Hydro Magnet on a pallet to protect the magnet plate from moisture from below.
- Remove the Hydro Magnet from the carrier (see chapter **Removing the hydraulic attachment from the carrier**).
- Clean the Hydro Magnet (see chapter **Cleaning**).
- Oil the magnet plate to protect it against corrosion.
- Store the Hydro Magnet in a dry, properly ventilated room at an ambient temperature of -0 °C to +45 °C. The air humidity must not exceed 80 %.
- If you can only store the Hydro Magnet in the open air, cover it with plastic sheeting or tarpaulins to protect it against the weather.
- Protect the packed Hydro Magnet with bags of hygroscopic salts, when the humidity rises to more than 80 %.
- Store the Hydro Magnet in an upright position and so that it cannot topple over on a pallet.
- Have the Hydro Magnet checked after prolonged storage. Consult the Epiroc Customer Center / Dealer in your area.

11 Disposal

NOTICE Environmental damage due to consumables

Hydraulic oil and cutter grease are environmentally harmful and must not penetrate the ground or enter the water table or water supplies.

- ▶ Collect any such consumables which may escape.
- ▶ Dispose of them in accordance with the applicable environmental regulations.

11.1 Hydro Magnet

- Remove the Hydro Magnet from the carrier (see chapter **Removing the hydraulic attachment from the carrier**).
- Remove the adapter plate (see chapter **Removing the adapter plate**).
- Remove the hydraulic hoses from the Hydro magnet.
- Dispose of the Hydro Magnet in line with all applicable regulations or consult an authorised and specialised recycling company.

11.2 Hydraulic hoses

- Drain the hydraulic oil from the hydraulic hoses and collect it.
- Dispose of the hydraulic hoses in accordance with the applicable regulations to avoid environmental hazards.

11.3 Hydraulic oil

- Collect any hydraulic oil that escapes.
- Dispose of it in accordance with the applicable environmental regulations.

12 Technical specifications

Type	HM 1500 F	HM 1500 M	HM 2000 F	HM 2000 M
Carrier weight class ¹	12 - 30 t (26460 - 66140 lb)		15 - 45 t (33100 - 99200 lb)	
Service weight ²	1550 kg (3420 lb)		2000 kg (4410 lb)	
Weight without adapter	1360 kg (3000 lb)		1650 kg (3640 lb)	
Weight magnet plate	780 kg (1720 lb)		1100 kg (2430 lb)	
Dimensions magnet plate				
Diameter	1060 mm (42 in.)	1060 mm (42 in.)	1250 mm (49 in.)	1250 mm (49 in.)
Thickness	280 mm (11 in.)	280 mm (11 in.)	305 mm (12 in.)	305 mm (12 in.)
Dimensions Hydro Magnet:				
Complete height without adapter plate	1025 mm (40 in.)		1050 mm (41 in.)	
stabled		1230 mm (48 in.)		1255 mm (49 in.)
extended		1580 mm (62 in.)		1605 mm (63 in.)
Generator performance	13 kW (17 hp)		13 kW (17 hp)	
Magnet performance	9 kW (12 hp)		10.9 kW (14.6 hp)	
Operating pressure	120 - 310 bar (1741 - 4496 psi)		120 - 310 bar (1741 - 4496 psi)	
recommended	> 250 bar (3626 psi)		> 250 bar (3626 psi)	
Return pressure	max. 20 bar (290 psi)		max. 20 bar (290 psi)	
Leak oil pressure	max. 4 bar (58 psi)		max. 4 bar (58 psi)	
Oil flow	90 - 250 l/min (23.8 - 66.0 gal/min)		90 - 250 l/min (23.8 - 66.0 gal/min)	
recommended	140 l/min (37.0 gal/min)		140 l/min (37.0 gal/min)	
Control line				
Oil pressure	50 bar (725 psi)		50 bar (725 psi)	
Oil flow	20 l/min (5.3 gal/min)		20 l/min (5.3 gal/min)	
Hose inside diameter »P« (Pressure line)	25 mm (1 in.)		25 mm (1 in.)	
Hose inside diameter »T« (Tank line)	25 mm (1 in.)		25 mm (1 in.)	
Hose inside diameter control line (Magnet plate magnetize / demagnetize)	12 mm (0.47 in.)		12 mm (0.47 in.)	
Tear-off-force ³	11500 kg (25355 lb)		15000 kg (33070 lb)	
Load capacity Skelps, Blocks	5750 kg (12680 lb)		7500 kg (16535 lb)	
Load capacity Iron balls	2600 kg (5730 lb)		3500 kg (7716 lb)	
Load capacity Pig irons	280 kg (706 lb)		410 kg (904 lb)	
Load capacity Scrap 3A*	255 kg (560 lb)		370 kg (816 lb)	
Load capacity Scrap 24**	240 kg (530 lb)		360 kg (794 lb)	
Load capacity Scrap 40***	120 kg (265 lb)		190 kg (419 lb)	
Hole pattern (group)	9		9	

¹ Weight apply to standard carriers only.

Any variations must be agreed with Epiroc and / or the carrier manufacturer.

² Hydro Magnet including adapter plate of medium size

Please note that the working weight can be considerably higher, depending on the adapter plate.

³ For the static test coefficient used = 1.5

* 2.2 to 2.5 t/m³ ** 1.9 to 2.0 t/m³ *** 0.8 to 1.0 t/m³

13 EC Declaration of Conformity (EC Directive 2006/42/EC)

We, Construction Tools GmbH, hereby declare that the machines listed below conform to the provisions of EC Directive 2006/42/EC (Machinery Directive), 2004/108/EC (EMC Directive), and the harmonised standards mentioned below.

Hydro Magnet

HM 1500 F

HM 1500 M

HM 2000 F

HM 2000 M

Following harmonised standards were applied:

- EN ISO 12100
- EN 60204-1
- EN 60204-32
- EN 13155
- EN 13309
- EN 61000-6
- EN 55011

Technical Documentation authorised representative:

Tobias Waldt

Construction Tools GmbH

45143 Essen

Germany

Authorised Representative:

see respective separate original EC declaration of conformity

Manufacturer:

Construction Tools GmbH

45143 Essen

Germany

Any unauthorized use or copying of the contents or any part thereof is prohibited. This applies in particular to trademarks, model denominations, part numbers, and drawings.

© Construction Tools GmbH | 3390 5149 01 | 2026-05-06