

Spare parts list Hydraulic breakers

	Valid from serial number
SB 302 Scaler	BES8861

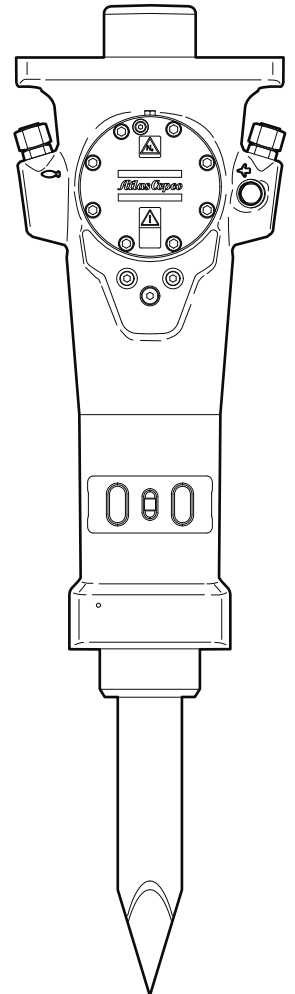

Contents

General information	5
Spare parts list	6
Optional parts	10
Bushing oversize, complete.....	10
Bushing press fit, complete.....	12
Restrictor, complete.....	14
Tightening torque	16
Working tools	17
Accessories	18
Optional equipment	18
Hydraulic hoses	18
Kits	19
Label kit	19
Seal kit	20
Lower hammer part kit	21
Accumulator repair kit	22
Dimensions	23

General information

This spare parts list applies to the following:

Part number	Description
8460 0300 62	Hydraulic breaker SB 302 Scaler

Use only authorized parts. Any damage or malfunction caused by the use of unauthorized parts is not covered by Warranty or Product Liability. Any unauthorized use or copying of the contents or any part thereof is prohibited. This applies in particular to trademarks, model denominations, part numbers, and drawings.

Instructions for use

This spare parts list contains no safety regulations and is merely intended to assist in the ordering of spare parts.

For information about operating, servicing, or repairing, the relevant Safety and operating instructions must be consulted at all costs.

Please observe the safety instructions listed in the relevant Safety and operating instructions!

Spare parts list

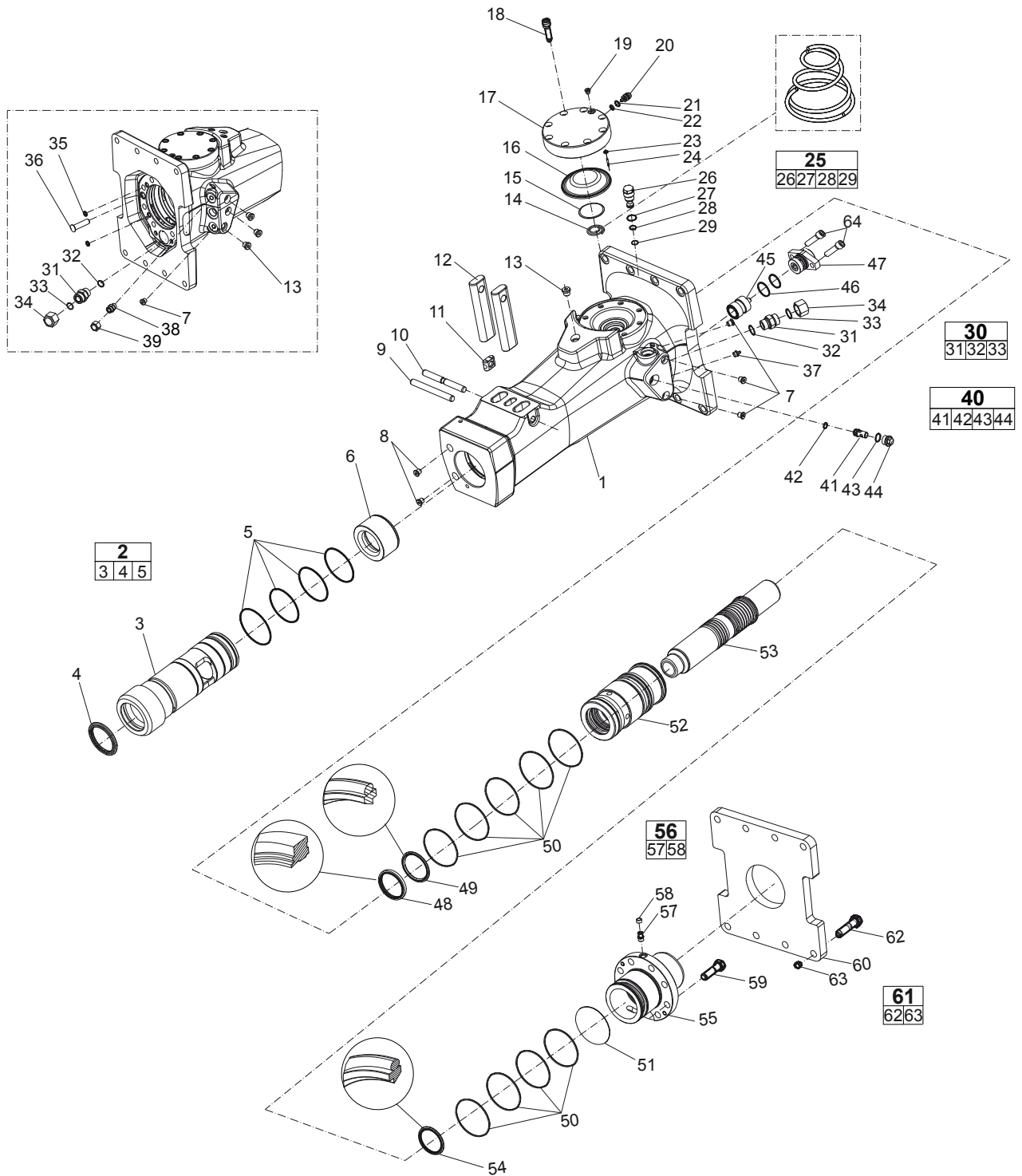

No.	Description	Remark	Quantity	Part number
1	Breaker body		1	-
2(3-5)	Bushing standard, complete	For oversize bushings, see section "Bushing oversize, complete".	1	3315 3019 80
3	Bushing	Ø110 mm Ø4.33 in.	1	-
4	Scraper ring		1	3315 3250 00
5	O-ring	99.5 x 3 mm 3.92 x 0.12 in. (70 shore)	4	0663 2106 17
6	Stop ring		1	3315 3014 00
7	Plug	VSTI R ¼ - ED	4	0686 6442 07
8	Water nozzle		2	3315 3952 00
9	Spring pin, option		1	0108 1691 28
10	Lock pin		1	3315 2031 00
11	Lock buffer		1	3315 1419 00
12	Tool retainer		2	3315 2030 00
13	Hexagon socket plug	VSTI R ⅜ - ED	4	0686 3718 01
14	Coil spring		1	3315 3035 00
15	Diaphragm support		1	3315 4007 00
16	Diaphragm		1	3315 2350 00
17	Accumulator house		1	3315 3487 00
18	Hexagon socket screw	Screw with extra high fatigue strength.	8	0211 1965 34
19	Plug	VSTI R ¼ - ED	1	0686 3718 05
20	Charge valve		1	3315 3660 00
21	O-ring	13.3 x 2.4 mm 0.52 x 0.094 in. (70 shore)	1	0663 2120 00
22	Seal ring		1	3115 3290 02
23	O-ring	7.3 x 2.4 mm 0.29 x 0.094 in. (90 shore)	1	0663 2114 00
24	Parallel pin	D4 x 25 mm	1	0101 4140 00
25(26-29)	Pressure relief valve, complete		1	3315 3658 00
26	Pressure relief valve		1	-
27	O-ring	20.35 x 1.78 mm 0.80 x 0.07 in. (90 shore)	1	9125 6211 00
28	O-ring	14 x 1.78 mm 0.55 x 0.07 in. (90 shore)	1	0663 2104 21
29	Back-up ring		1	0661 2004 01
30(31-33)	Nipple, complete	There are two "Nipple, complete" on the machine.	1	0570 7000 04
31	Nipple	1 ⅜ - 12UN G¾A	1	-
32	Seal ring		1	0664 0000 04
33	O-ring		1	0663 2102 17
34	Cap		2	0570 7000 10
35	Seal		2	0665 0900 14
36	Plug		1	3315 3367 00
37	Grease nipple		1	0544 2153 00
38	Water inlet nipple		1	3176 6348 00
39	Cap		1	3176 5429 00
40(41-44)	Restrictor, complete	For more restrictors, see section "Restrictor, complete".	1	3315 3694 67
41	Restrictor	Ø 6.7 mm Ø 0.26 in.	1	-
42	O-ring	14 x 1.78 mm 0.55 x 0.07 in. (90 shore)	1	0663 2104 21
43	O-ring	20.35 x 1.78 mm 0.80 x 0.07 in. (90 shore)	1	9125 6211 00
44	Restrictor plug		1	-

No.	Description	Remark	Quantity	Part number
45	Control valve		1	3315 2776 00
46	O-ring	36.17 x 2.62 mm 1.42 x 0.10 in. (90 shore)	2	0663 2114 44
47	Valve cover		1	3315 3520 13
48	Wiper		1	0665 9099 57
49	Piston rod seal		1	0665 0701 37
50	Seal ring		9	0663 9900 31
51	Seal ring		1	0663 2106 69
52	Liner		1	3315 3017 00
53	Piston		1	3315 3021 00
54	Piston rod seal		1	0665 0701 46
55	Back head		1	3315 3020 00
56(57-58)	Check valve, complete		1	3315 2448 81
57	Check valve		1	-
58	Valve rubber		1	3315 2808 00
59	Hexagon head screw	M16 x 60 mm 8.8	8	0147 1481 03
60	Base plate		1	3315 3566 00
61(62-63)	Set of screws, complete		1	3315 3653 60
62	Hexagon head screw	M16 x 60 mm 8.8	8	0147 1481 03
63	Nut	M16	8	-
64	Hexagon socket screw	Screw with extra high fatigue strength.	2	0211 1103 49

Optional parts

Bushing oversize, complete

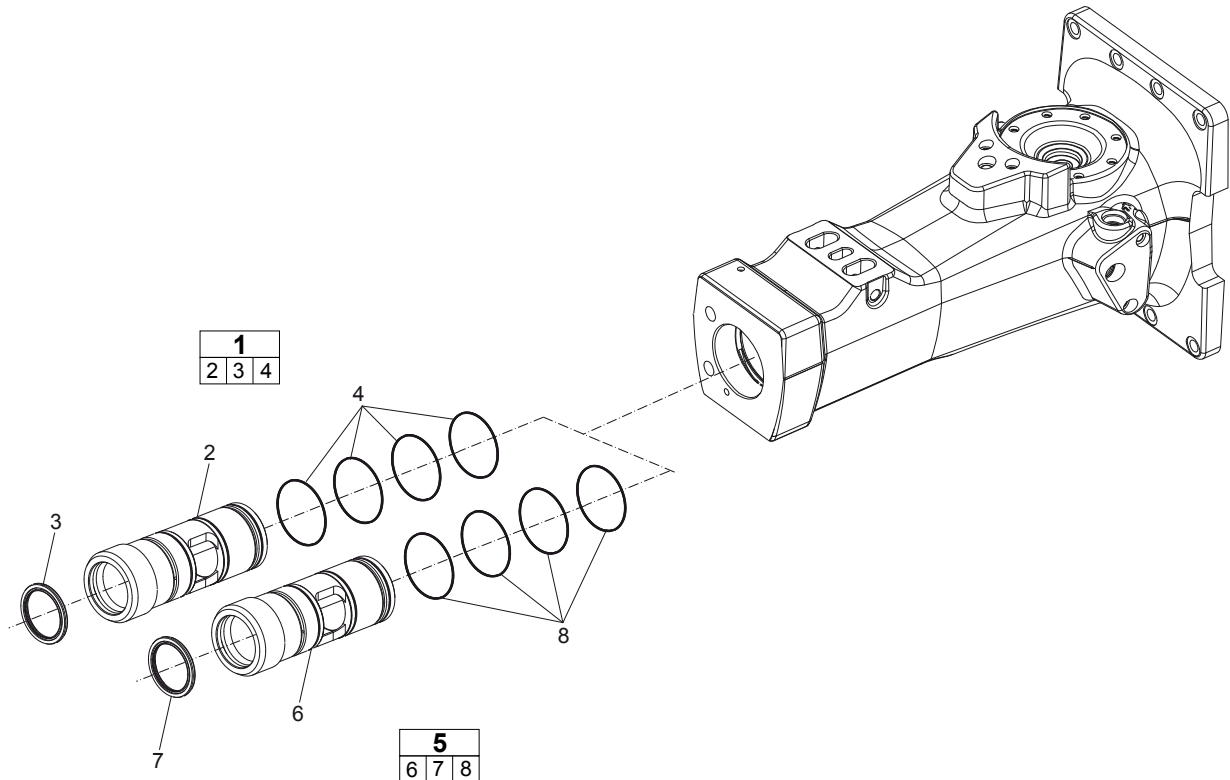

No.	Description	Remark	Quantity	Part number
1(2-4)	Bushing oversize, complete		1	3315 3019 60
2	Bushing	Ø111.5 mm Ø4.39 in.	1	-
3	Scraper ring		1	3315 3250 00
4	O-ring	99.5 x 3 mm 3.92 x 0.12 in. (70 shore)	4	0663 2106 17
5(6-8)	Bushing oversize, complete		1	3315 3019 63
6	Bushing	Ø113 mm Ø4.45 in.	1	-
7	Scraper ring		1	3315 3250 00
8	O-ring	99.5 x 3 mm 3.92 x 0.12 in. (70 shore)	4	0663 2106 17

Bushing press fit, complete

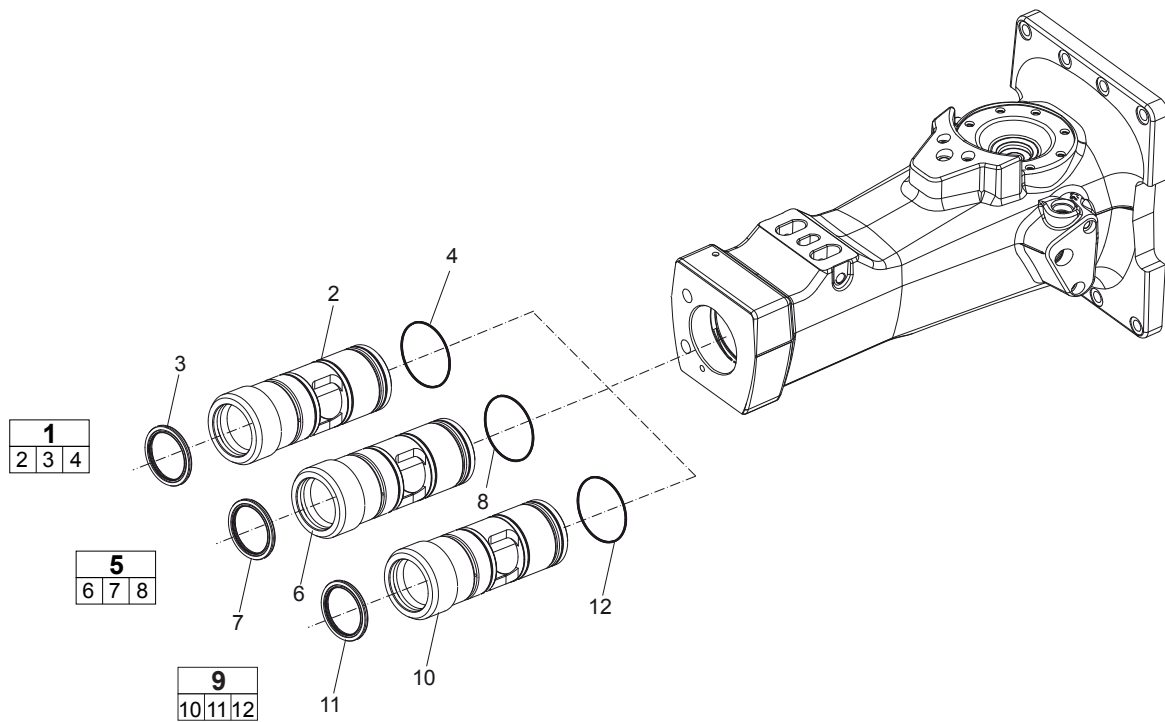

No.	Description	Remark	Quantity	Part number
1(2-4)	Bushing press fit standard, complete		1	3315 4098 00
2	Bushing	Ø110 mm Ø4.33 in.	1	-
3	Scraper ring		1	3315 3250 00
4	O-ring	99.5 x 3 mm 3.92 x 0.12 in. (70 shore)	1	0663 2106 17
5(6-8)	Bushing press fit oversize, complete		1	3315 4099 00
6	Bushing	Ø111.5 mm Ø4.39 in.	1	-
7	Scraper ring		1	3315 3250 00
8	O-ring	99.5 x 3 mm 3.92 x 0.12 in. (70 shore)	1	0663 2106 17
9(10-12)	Bushing press fit oversize, complete		1	3315 4100 00
10	Bushing	Ø113 mm Ø4.45 in.	1	-
11	O-ring	99.5 x 3 mm 3.92 x 0.12 in. (70 shore)	1	0663 2106 17
12	Scraper ring		1	3315 3250 00

Restrictor, complete

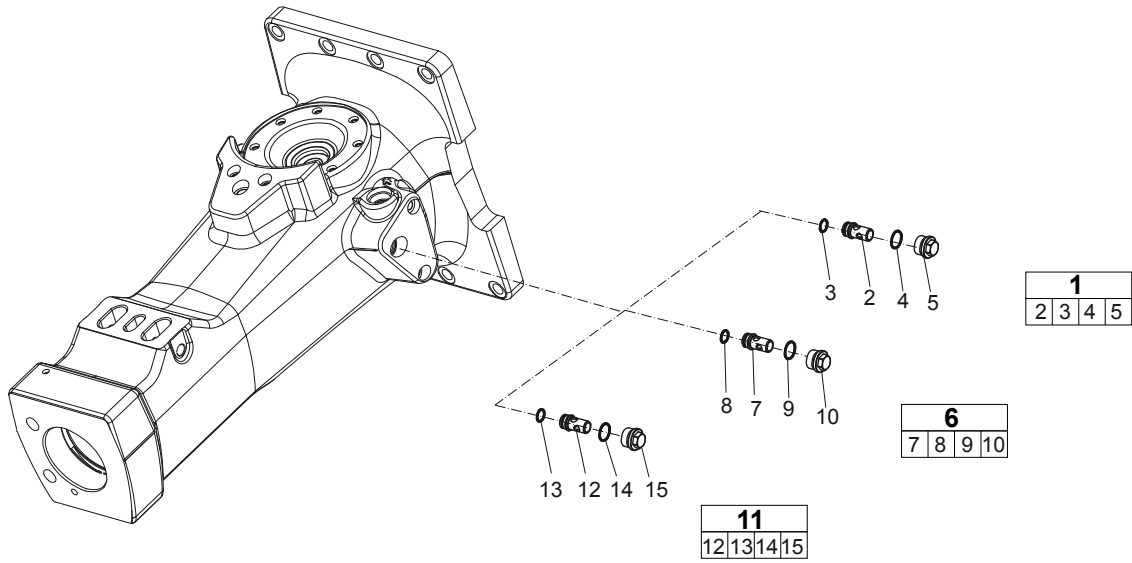

No.	Description	Remark	Quantity	Part number
1(2-5)	Restrictor, complete		1	3315 3694 54
2	Restrictor	Ø 5.4 mm Ø 0.21 in.	1	-
3	O-ring	14 x 1.78 mm 0.55 x 0.07 in. (90 shore)	1	-
4	O-ring	20.35 x 1.78 mm 0.80 x 0.07 in. (90 shore)	1	-
5	Restrictor plug		1	-
6(7-10)	Restrictor, complete		1	3315 3694 60
7	Restrictor	Ø 6.0 mm Ø 0.24 in.	1	-
8	O-ring	14 x 1.78 mm 0.55 x 0.07 in. (90 shore)	1	-
9	O-ring	20.35 x 1.78 mm 0.80 x 0.07 in. (90 shore)	1	-
10	Restrictor plug		1	-
11(12-15)	Restrictor, complete		1	3315 3694 64
12	Restrictor	Ø 6.4 mm Ø 0.25 in.	1	-
13	O-ring	14 x 1.78 mm 0.55 x 0.07 in. (90 shore)	1	-
14	O-ring	20.35 x 1.78 mm 0.80 x 0.07 in. (90 shore)	1	-
15	Restrictor plug		1	-

Tightening torque

No.	Description	Tightening torque	Remark
7	Plug	30 Nm	LOCTITE® 243™
13	Hexagon socket plug	80 Nm	LOCTITE® 243™
18	Hexagon socket screw	120 Nm	Molykote®
19	Plug	20 Nm	
20	Charge valve	20 Nm	
26	Pressure relief valve	80 Nm	
31	Nipple	210 Nm	
37	Grease nipple	30 Nm	
44	Restrictor plug	80 Nm	
57	Check valve	30 Nm	LOCTITE® 243™
59	Hexagon head screw	180 Nm	Molykote®
63	Nut	200 Nm	Molykote®
64	Hexagon socket screw	180 Nm	Molykote®

LOCTITE is a registered trademark of Henkel Corporation. 243 is a trademark of Henkel Corporation.

Molykote is a registered trademark of Dow Corning Corporation.

Working tools

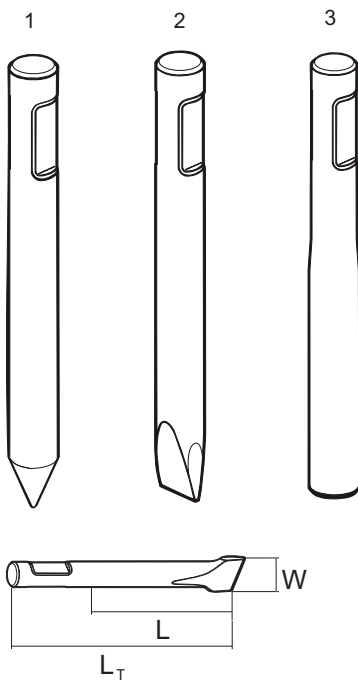

Metric

No.	Description	W (mm)	L (mm)	L_T (mm)	Wt (kg)	Part number
1	Moil point	-	420	800	28	3083 3191 00
2	Chisel (cross)	80	420	800	28	3083 3192 00
3	Blunt tool	-	420	800	30	3083 3195 00

Imperial

No.	Description	W (in.)	L (in.)	L_T (in.)	Wt (lb)	Part number
1	Moil point	-	16.5	31.5	1.10	3083 3191 00
2	Chisel (cross)	3.15	16.5	31.5	1.10	3083 3192 00
3	Blunt tool	-	16.5	31.5	1.18	3083 3195 00

Accessories

Optional equipment

Description	Remark	Quantity	Part number
Grease gun	For manual greasing with cartridge, 400 g (0.88 lb)	1	0909 1071 00
Chisel paste cartridge	400 g x 12 0.88 lb x 12	1	3363 0949 13
ContiLube™ II micro		1	3315 3831 90
Welding kit, universal	For ContiLube™ II micro	1	3315 3867 80
Hose kit, universal	For ContiLube™ II micro	1	3315 3862 80
Chisel paste cartridge	150 g x 12 0.33 lb x 12	1	3363 1064 47
Filling device	For the 150 g (0.33 lb) Chisel paste cartridges, to use in combination with Chisel paste container 15 kg (33 lb)	1	3363 0946 69
Filling adapter	For the 150 g (0.33 lb) Chisel paste cartridges, suitable with the filling device for 15 kg (33 lb) and 45 kg (99 lb)	1	3315 3839 80
Filling device	For the 150 g (0.33 lb) Chisel paste cartridges, to use in combination with Chisel paste container 45 kg (99 lb)	1	3363 0664 11
Chisel paste container	15 kg 33 lb	1	3362 2639 00
Chisel paste container	45 kg 99 lb	1	3362 2632 75
Filling device for accumulator		1	3360 9204 15
Nipple, for charging the accumulator		1	3363 0944 59
Filling hose, for charging the accumulator		1	3361 3298 03
Bushing wear controller		1	3315 3531 00

Hydraulic hoses

Description	Remark	Quantity	Part number
Hose	I.D. 16 (0.63 in.), both ends M26 x 1.5 mm conical seal 24°, length 1.5 m (59 in.)	2	3360 9957 17
Hose	I.D. 16 (0.63 in.), both ends M26 x 1.5 mm conical seal 24°, length 2.0 m (79 in.)	2	3362 2351 59
Hose	I.D. 16 (0.63 in.), both ends M26 x 1.5 mm conical seal 24°, length 2.4 m (94 in.)	2	3363 0833 13
Additional fitting kit	Needed to fit two hoses to the hydraulic breaker	1	3363 0980 19

Kits

Label kit

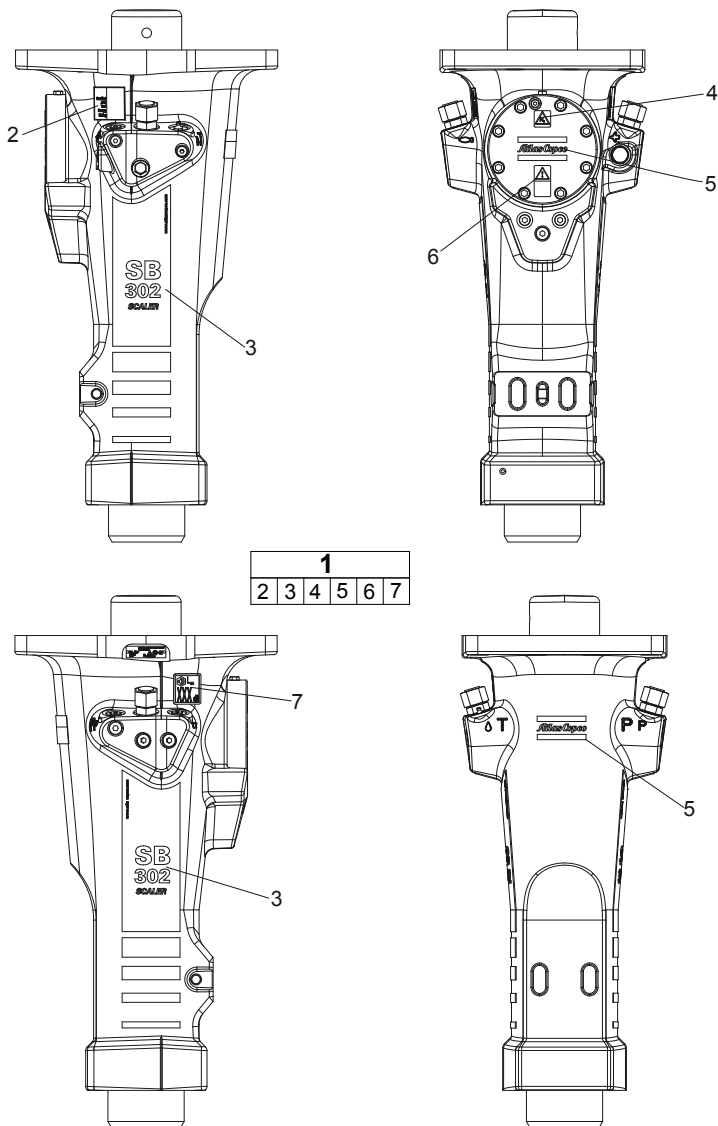

No.	Description	Remark	Quantity	Part number
1(2-7)	Label kit		1	3315 3493 91
2	AEM label		1	-
3	Product label	"SB 302 Scaler"	2	-
4	Safety label		1	-
5	Product label	"Atlas Copco"	2	-
6	Safety label		1	-
7	Noise level label		1	-

Seal kit

Description	Remark	Quantity	Part number
Seal kit		1	3315 3018 90
Scraper ring		1	3315 3250 00
O-ring	13.3 x 2.4 mm 0.52 x 0.094 in. (70 shore)	1	0663 2120 00
Seal ring		1	0661 1000 24
Seal ring		1	3115 3290 02
O-ring	99.5 x 3 mm 3.92 x 0.12 in. (70 shore)	4	0663 2106 17
O-ring	133.07 x 1.78 mm 5.24 x 0.070 in. (70 shore)	1	0663 2106 69
O-ring	7.3 x 2.4 mm 0.29 x 0.094 in. (90 shore)	1	0663 2114 00
Seal ring		9	0663 9900 31
O-ring	36.17 x 2.62 mm 1.42 x 0.10 in. (90 shore)	2	0663 2114 44
O-ring	14 x 1.78 mm 0.55 x 0.070 in. (90 shore)	2	0663 2104 21
O-ring	20.35 x 1.78 mm 0.80 x 0.070 in. (90 shore)	2	9125 6211 00
Back-up ring		1	0661 2004 01
Seal ring		2	0665 0900 14
Plug		1	3315 3367 00
Wiper		1	0665 9099 57
Piston rod seal		1	0665 0701 37
Piston rod seal		1	0665 0701 46
Valve rubber		1	3315 2808 00

Lower hammer part kit

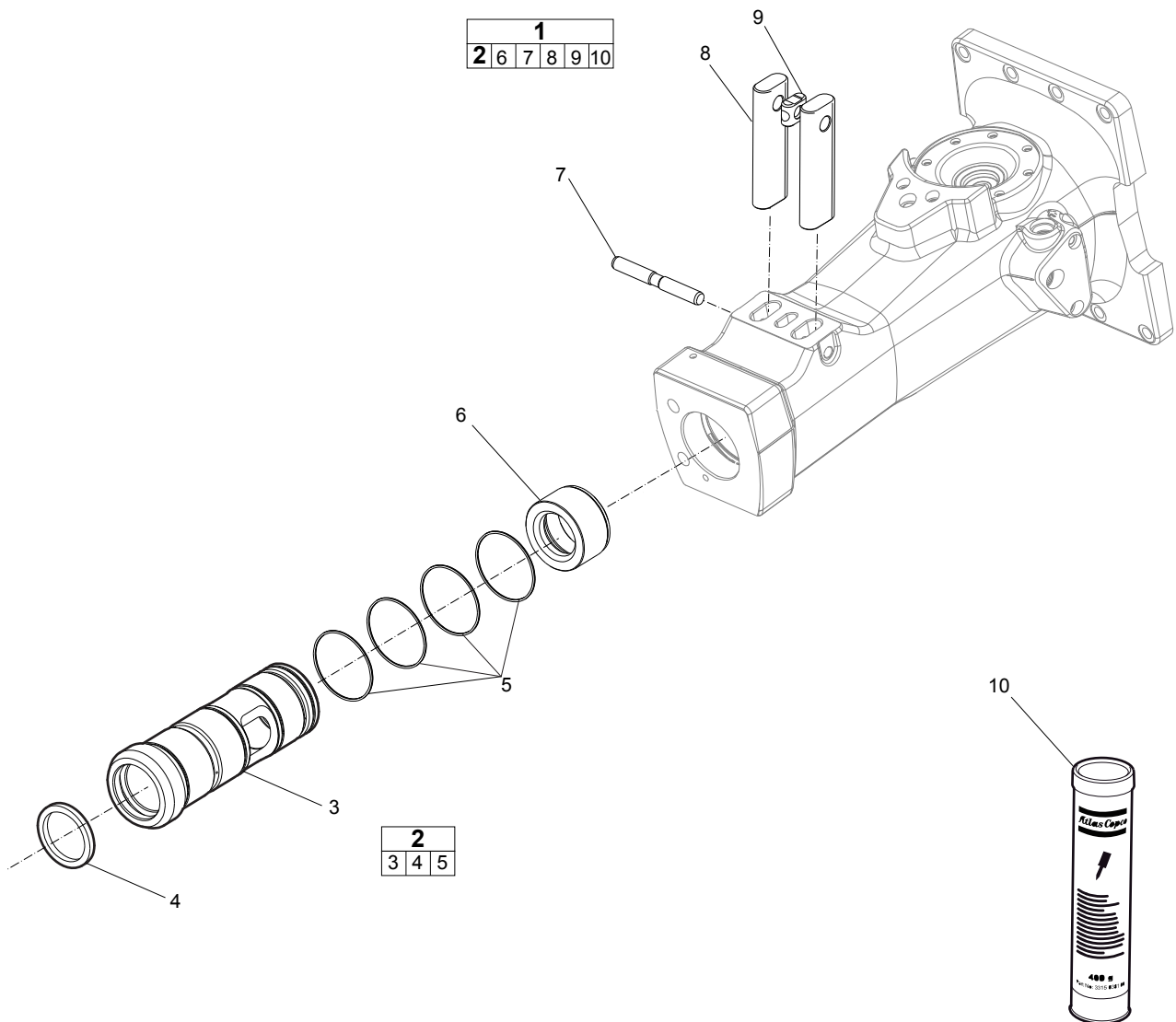

No.	Description	Remark	Quantity	Part number
1(2,6-10)	Lower hammer part kit		1	3315 3019 90
2(3-5)	Bushing, complete		1	3315 3019 80
3	Bushing		1	-
4	Scraper ring		1	3315 3250 00
5	O-ring	99.5 x 3 mm 3.17 x 0.12 in.	4	0663 2106 17
6	Stop ring		1	3315 3014 00
7	Lock pin		1	3315 2031 00
8	Tool retainer		2	3315 2030 00
9	Lock buffer		1	3315 1419 00
10	Chisel paste cartridge 400 g		1	-

Accumulator repair kit

Description	Remark	Quantity	Part number
Accumulator repair kit		1	3315 3487 90
Coil spring		1	3315 3035 00
Diaphragm support		1	3315 4007 00
Diaphragm		1	3315 2350 00
Seal ring		1	3115 3290 02
O-ring	13.3 x 2.4 mm 0.52 x 0.094 in. (70 shore)	1	0663 2120 00
Charge valve		1	3315 3660 00
O-ring	7.3 x 2.4 mm 0.29 x 0.094 in. (90 shore)	1	0663 2114 00
Parallel pin	D4 x 25 mm	1	0101 4140 00
Hexagon socket screw	Screw with extra high fatigue strength.	8	0211 1965 34
Plug		1	0686 3718 05

Dimensions

mm (inch)

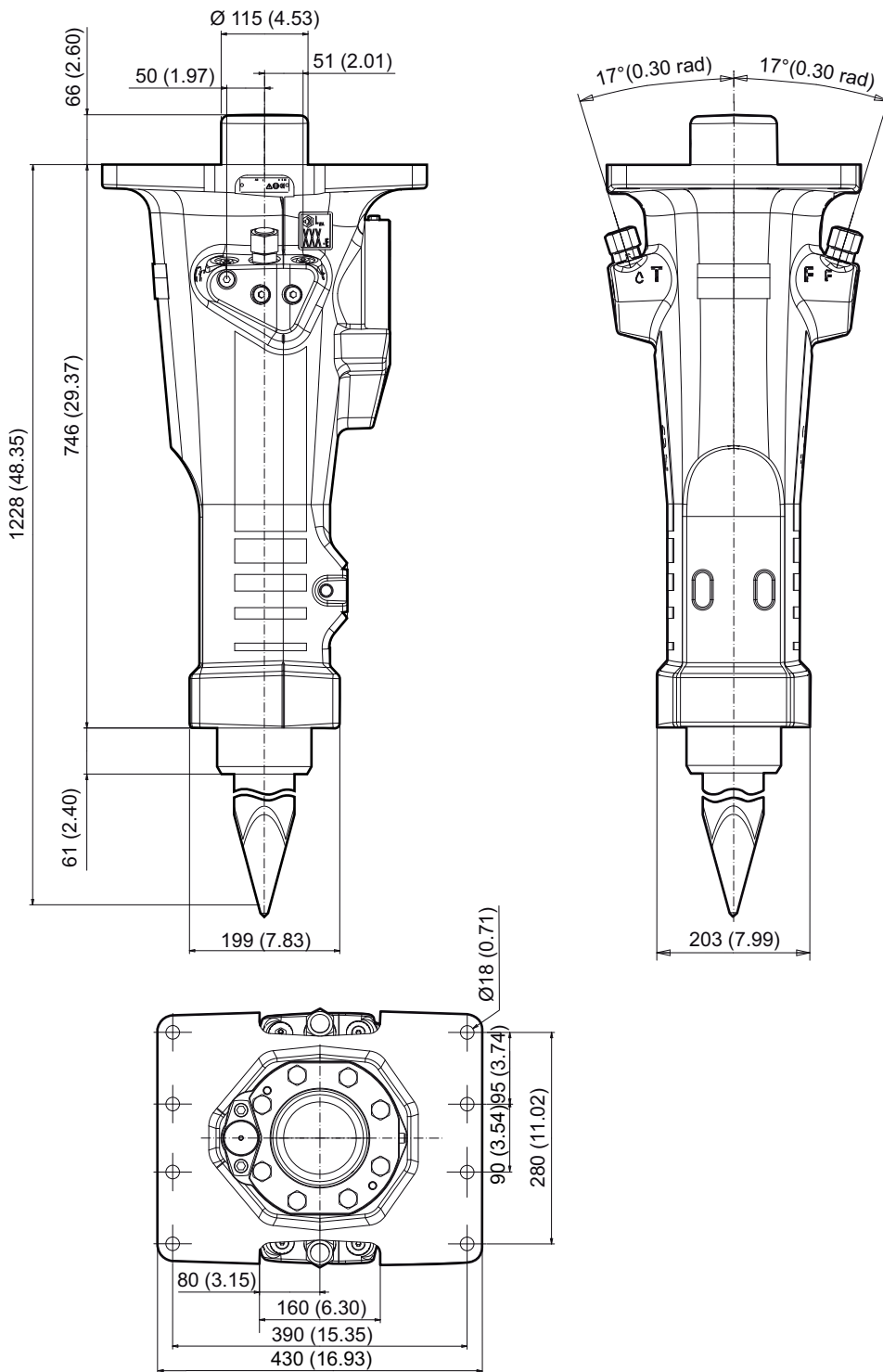

Any unauthorized use or copying of the contents or any part thereof is prohibited.
This applies in particular to trademarks, model denominations, part numbers, and
drawings.

© 2013 Atlas Copco Construction Tools AB | No. 9800 0977 01f | 2013-03-01

Atlas Copco

www.atlascopco.com